



## Planning Commission MEETING AGENDA

Thursday, April 17, 2025 - 1:00 PM  
Council Chambers, Easton Town Office  
14 S Harrison Street

### 1. Call to Order

### 2. Approval of Minutes

- a. Approval of the draft Decision Summary from the March 20, 2025 meeting.

### 3. Old Business

- a. **Application Number:** 2025 - 1391  
**Applicant:** Lane Engineering LLC  
**Location:** 8275 Ocean Gateway  
Tax Map 0103, Grid 00EA, Parcel 2861  
**Zoning District:** CG  
**Request:** Architectural approval for the redevelopment of the existing property and structure to be converted to a fast-food establishment (Zaxbys).

### 4. New Business

### 5. Discussion Item

- a. Pattern Books and Design Guidelines: A discussion with Jay Corvan on developing and incorporating a pattern book for development.
- b. Continued Discussion of the Comprehensive Plan Update.
- c. Legislative Update.

### 6. Adjournment



**Town of Easton Planning Commission  
Draft Decision Summary**

Thursday, March 20, 2025 at 1:00 p.m.  
Town Hall Chamber 2  
14 S. Harrison Street, Easton, Maryland

**Archived video of the meeting is available at:**

[Town of Easton Agendas and Minutes  
\(eastonmd.gov\)](http://eastonmd.gov)

**Attendance:**

Commission Members:

Philip Toussaint, Chairperson  
Michael Ports, Vice Chairperson  
Tom Klein  
William Ryall

**Absent:**

Commission Members:

Victoria McAndrews  
Laurie Forster, Alternate

Staff:

Lynn B. Thomas AICP, Town Planner  
Joseph Mayer, Plan Reviewer  
Nicholas Johnson AICP, Planner  
William Chapman *Esq.* Asst. Town Attorney  
Sierra Clem, Engineering Technician  
Samantha Smith, Administrative Specialist

Staff:

Miguel Salinas, Planning and Zoning Director

~~1. **Call to Order** — The meeting was called to order at 1:00 pm. Chairperson Toussaint addressed the Applicants, explaining that though a quorum of four out of five members are present, any motion to pass requires a majority vote of the full five member Commission as per the Planning Commission Bylaws. Chairperson Toussaint offered all Applicants the choice to proceed, or to continue their application to a future meeting with the presence of a full Board. All Applicants agreed to proceed with their applications.~~

**The meeting was called to order at 1:00 pm. As per the Planning Commission Bylaws, any motion to pass requires a majority vote of the full five members of the Commission. Chairperson Toussaint offered all Applicants the choice to proceed, or to continue their application to a future meeting with the presence of a full Board. All Applicants agreed to proceed with their applications.**

**2. Decision Summary Review —**

55 a. February 20, 2025 - The Commission noted the following correction to the draft  
56 decision summary:

57  
58 i. Line 177: Strike “bird strike mitigation”, Add “bird building collision”.

59  
60 **Commissioner Ryall moved to approve the February 20, 2025 Decision Summary**  
61 **with amendments. Vice Chairperson Ports seconded the motion.**

62  
63 Vote 4 - 0 - 1  
64 FOR: 4 - Toussaint, Ports, Klein, Ryall  
65 AGAINST: 0  
66 ABSTAIN: 0  
67 ABSENT: 1 - McAndrews

68  
69  
70 **3. Old Business**

71  
72 a. **File No.:** 2023 - 0989  
73 **Applicant:** Far Eastern Shore Winery  
74 **Location:** 8370 & 8374 Ocean Gateway, Easton, MD 21601  
75 Tax Map 0103, Grid 00EA, Parcel 2952  
76 **Zoning:** CG  
77 **Request:** The Applicant is seeking an amendment to a previously approved  
78 master signage plan for a freestanding sign located on a multi-building property.  
79 The readerboard attached to the freestanding sign will be replaced with three (3)  
80 horizontal panels. Additionally, the Applicant is proposing changes to the  
81 building lettering including the removal of the lettering on the awnings to be  
82 replaced with a solid color, and to change the lettering of the front building sign to  
83 read “Far Eastern Shore Winery \* Distillery”.

84  
85 **Background:** On September 21, 2023 the Commission voted unanimously to  
86 approve a master signage plan application to permit a 19’ non-conforming  
87 freestanding sign with a 156” x 46.15” sign, and a 108” x 18” readerboard sign  
88 subject to the condition that the Applicant shall obtain the appropriate building  
89 permits for the installation of the signs.

90  
91 Staff recommends the following condition:

- 92  
93 1. Obtain the appropriate building permits for the installation of the signs,  
94 and to coordinate with the Planning and Zoning Department for the  
95 proposed illumination of the sign prior to final signage approval.

96  
97 **Staff Presentation:**  
98 Joseph Mayer, Plan Reviewer  
99 Lynn Thomas, Town Planner

100

101 **Applicant Presentation:**  
102 Tien Seng-Chiu,  
103 Tara Seng-Chiu,  
104 Carol Prettyman, Rejoice LLC

105  
106 **Public Comment** — None  
107 **Public Comment Written** — None

108  
109 **Commissioner Ports moved to approve the amended master signage plan subject to**  
110 **the following condition:**

- 111  
112 **1. The Applicant shall obtain appropriate building permits for the installation**  
113 **of the signs, and shall coordinate with the Planning and Zoning Department**  
114 **for the proposed illumination of the sign prior to final signage approval.**

115  
116 **Commissioner Klein seconded the motion.**

117  
118 Vote 4 - 0 - 1  
119 FOR: 4 - Toussaint, Ports, Klein, Ryall  
120 AGAINST: 0  
121 ABSTAIN: 0  
122 ABSENT: 1 - McAndrews

123  
124  
125 **4. New Business**

- 126  
127 **a. File No.: 2025 - 1480**  
128 **Applicant: Rauch Inc.**  
129 **Location:** 9095 Mistletoe Drive, Easton, MD 21601  
130 Tax Map 0025, Grid 0016, Parcel 0138, Lot 8  
131 **Zoning:** I  
132 **Request:** The Applicant is seeking a landscape and buffer waiver from  
133 Section 28-1014.7.E.5(c)1-3 of the Zoning Code. In order to mitigate potential  
134 fire and safety hazards, the Applicant is seeking to remove the existing trees along  
135 the southwest property line of the new Easton Volunteer Fire Department training  
136 facility that borders the Talbot County Airport.

137  
138 Staff recommends the following condition:

- 139  
140 1. Upon Planning Commission approval, the Applicant is required to submit  
141 a revised site plan for review and approval prior to the removal of any  
142 trees.

143  
144 **Staff Presentation:**  
145 Joseph Mayer, Plan Reviewer  
146 Lynn Thomas, Town Planner

147 Sierra Clem, Engineering Technician

148

**Applicant Presentation:**

149 Brian Fitzgerald, Rauch Inc.

150 Daryl Caldwell, Easton Volunteer Fire Department

151

152 **Public Comment** — None

153

154 **Public Comment Written** — None

155

156 **Commissioner Ryall moved to approve the waiver request subject to the following**  
157 **conditions:**

158

159 **1. The Applicant shall submit a revised site plan for review and approval prior**  
160 **to the removal of any trees.**

161

162 **2. Any subsequent change in ownership of the property shall require that the**  
163 **new owner complies with the minimum required landscaping and bufferyard**  
164 **screening.**

165

166 **Chairperson Toussaint seconded the motion.**

167

168 Vote 4 - 0 - 1

169

FOR: 4 - Toussaint, Ports, Klein, Ryall

170

AGAINST: 0

171

ABSTAIN: 0

172

ABSENT: 1 - McAndrews

173

174 **b. File No.: 2025 - 1369**

175

**Applicant: Lane Engineering LLC**

176

**Location:** 28580 Mary’s Court, Easton, MD 21601

177

Tax Map 0025, Parcel 0046, Lots 16 & 20

178

**Zoning:** BC

179

**Request:** The Applicant is seeking sketch site plan and architectural

180

approval for the development of Phase I of this proposal, including the

181

construction of two (2) 9,700 square foot pole buildings (Buildings ‘A’ and ‘B’)

182

with associated stormwater management facilities and other facility

183

improvements.

184

**Background:** On January 2, 2024 a growth allocation request was adopted by the

185

Town Council (*Ordinance No. 807*) and on April 23, 2024, the Talbot County

186

Council adopted *Bill No. 1551*, granting a supplemental growth allocation to the

187

Town. On July 29, 2024 the Critical Area Commission received the Town’s

188

request to reclassify the 8.348 acres of land via growth allocation from Resource

189

Conservation Area (RCA) to Intensely Developed Area (IDA).

190

At their September 19, 2024 meeting, the Planning Commission forwarded a

191

192

193 positive recommendation to the Town Council for the zoning reclassification of  
194 the subject property from Agricultural zoning district (A-1) to Business  
195 Commercial zoning district (BC). A map amendment for the zoning  
196 reclassification of the property was adopted by the Town Council on November  
197 18, 2024 (*Ordinance No. 836*).  
198

199 Staff recommend the following conditions:  
200

- 201 1. The Applicant will address all remaining Easton Staff Development  
202 Review (ESDR) comments, and submit a development site plan for  
203 review.  
204
- 205 2. The Applicant will coordinate with the Critical Area Commission and  
206 meet all required conditions set forth within the November 6, 2024 growth  
207 allocation determination.  
208
- 209 3. Phase II of the sketch site plan will require the Planning Commission’s  
210 review and approval.  
211

212 **Staff Presentation:**  
213 Joseph Mayer, Plan Reviewer  
214

215 **Applicant Presentation:**  
216 Brittany Wallace, Lane Engineering  
217 Sean Callahan, Lane Engineering  
218

219 **Public Comment** — None  
220 **Public Comment Written** — None  
221

222 **Vice Chairperson Ports moved to approve the sketch site plan and architecture**  
223 **subject to the following conditions:**  
224

- 225 1. **The Applicant shall address all remaining Easton Staff Development Review**  
226 **(ESDR) comments, and submit a development site plan for review.**  
227
- 228 2. **The Applicant shall coordinate with the Critical Area Commission and meet**  
229 **all required conditions set forth within the November 6, 2024 growth**  
230 **allocation determination.**  
231
- 232 3. **Phase II of the sketch site plan shall require the Planning Commission’s**  
233 **review and approval.**  
234

235 **Commissioner Ryall seconded the motion.**  
236

237 Vote 4 - 0 - 1  
238 FOR: 4 - Toussaint, Ports, Klein, Ryall

239 AGAINST: 0  
240 ABSTAIN: 0  
241 ABSENT: 1 - McAndrews  
242

- 243 **c. File No.: 2025 - 1391**  
244 **Applicant: Lane Engineering LLC**  
245 **Location:** 8275 Ocean Gateway, Easton, MD 21601  
246 Tax Map 0103, Grid 00EA, Parcel 2861  
247 **Zoning:** CG  
248 **Request:** The Applicant is seeking architectural approval for the  
249 redevelopment of the existing property and structure located at 8275 Ocean  
250 Gateway to be converted to a fast-food establishment (Zaxbys). The Applicant is  
251 also seeking a supplemental waiver from the minimum landscaping and  
252 bufferyard requirements of Section 28-1014.6.E.1 and Section 28-1014.7.E.2.a&b  
253 of the Zoning Code.  
254

255 Staff recommend the following conditions:

- 256  
257 1. The Applicant is to address all remaining Easton Staff Development  
258 Review (ESDR) comments and submit a development site plan for review.  
259  
260 2. The Applicant will coordinate with the Talbot County Health Department  
261 and Building Inspection Division for all applicable permits prior to  
262 construction.  
263

264 **Staff Presentation:**

265 Joseph Mayer, Plan Reviewer  
266 Lynn Thomas, Town Planner  
267 Nicholas Johnson AICP, Planner  
268 William Chapman *Esq.* Asst. Town Attorney  
269 Sierra Clem, Engineering Technician  
270

271 **Applicant Presentation:**

272 Brett Ewing, Lane Engineering  
273 Curtis Snyder *Esq.*, Delmarva Real Estate Management Group, LLC  
274 **Tom Mitchell, Franchisee Owner**  
275

276 **Public Comment:**

277 [Tom Mitchell](#)  
278 Jay Corvan, AIA  
279

280 **Public Comment Written — None**  
281

282 **Vice Chairperson Ports moved to approve the supplemental waiver requests as**  
283 **submitted. Chairperson Toussaint seconded the motion.**  
284

285                   Vote                   4 - 0 - 1  
286                   FOR:                   4 - Toussaint, Ports, Klein, Ryall  
287                   AGAINST:            0  
288                   ABSTAIN:            0  
289                   ABSENT:             1 - McAndrews  
290

291                   **Vice Chairperson Ports moved to table the request for architectural approval. The**  
292                   **Applicant shall return to the Commission with colored elevations for an alternate**  
293                   **design. The elevations shall indicate the materials of the new scheme. Commissioner**  
294                   **Ryall seconded the motion.**  
295

296                   Vote                   4 - 0 - 1  
297                   FOR:                   4 - Toussaint, Ports, Klein, Ryall  
298                   AGAINST:            0  
299                   ABSTAIN:            0  
300                   ABSENT:             1 - McAndrews  
301

302  
303                   **5. Recess — Chairperson Toussaint called for a brief recess at 2:26 p.m. The meeting**  
304                   **was called to Order at 2:31 p.m.**  
305

306  
307                   **6. Discussion Items**  
308

- 309                   a. Pattern Books and Design Guidelines — Mr. Jay Corvan was present before the  
310                   Commission to introduce the concept of an architectural pattern book, and to seek  
311                   the Commission’s consideration ~~for the adoption of one~~. Mr. Corvan discussed  
312                   how pattern books as a design tool can help to establish community character  
313                   guidelines and streamline the development process. Additionally, Mr. Corvan  
314                   touched on form-based zoning, and how pattern books can offer guidance on  
315                   preferred architectural styles and building types.  
316

317                   ~~The Commission generally favored the idea of incorporating a pattern book~~  
318                   ~~specific to localized areas or historic corridors within the Town, but not for Town-~~  
319                   ~~wide implementation. The Commission expressed their hesitation, suggesting~~  
320                   **that pattern books could restrict design creativity by stifling the opportunity**  
321                   **for developers to explore new concepts and design approaches. Additionally,**  
322                   **the Commission suggested that that pattern books primarily focus on**  
323                   **historical architectural styles, rather than planning concepts of the**  
324                   **Comprehensive Plan such as mixed-use developments, diverse housing types,**  
325                   **multimodal transportation, pedestrian safety, and density management to**  
326                   **reduce urban sprawl. In lieu of an overall community plan, the Commission**  
327                   **indicated their interest in seeing examples of how a pattern book could be**  
328                   **incorporated on specific areas of Easton such as the Ocean Gateway**  
329                   **corridor, Marlboro Avenue, and the Historic District.** The Commission sought  
330                   input from the Historic District Commission, and advocated for the opportunity

331 for public feedback. The Commission will continue ~~to consider the adaptation of~~  
332 **their consideration for** an architectural pattern book in subsequent meetings.

333

334

335 **7. Adjournment** — Chairperson Toussaint moved to adjourn. Commissioner Ryall  
336 seconded the motion. The meeting was adjourned at 3:24 p.m.



**TOWN OF EASTON**  
**PLANNING & ZONING**  
 14 S Harrison Street, Easton MD 21601

**Date of Meeting:** April 17, 2025

**# 3a**

**PLANNING COMMISSION  
 SUPPLEMENTAL ITEM**

**SUBJECT:** 8275 Ocean Gateway - Zaxbys

**ELECTION WARD:** Ward 2

**CRITICAL ACTION DATE:** At the pleasure of the Commission

**STAFF CONTACTS:** Joseph Mayer, Plan Reviewer  
 Miguel Salinas, Director of Planning and Zoning

**DOCUMENT CREATED ON:** March 31, 2025

**PURPOSE:** The applicant is seeking architectural approval from the Planning Commission.

**RECOMMENDATION:**

**Planning Commission:** The Commission, at their March 20, 2024 meeting, voted (4-0) to approve the supplemental waiver request from the minimum landscape and bufferyard requirements of Section 28-1014.6.E.1, and Section 28-1014.7.E.2.a & b of the Zoning Code; and voted (4-0) to table the request for architectural approval. The Applicant shall return to the Commission with colored elevations for an alternate design. The elevations shall indicate the materials of the new scheme.

**Staff:** Staff supports Planning Commission approval of the proposed architecture.

**UPDATE:**

On February 26, 2025, Delmarva Real Estate Management Group, LLC (Applicant), submitted an application to the Easton Staff Development Review Committee.

On March 20, 2024, the Applicant, requested architectural approval and a landscape and buffering waiver from the Town of Easton Planning Commission for the construction of a Zaxbys fast-food restaurant with parking, stormwater management and landscaping. Associated site improvements include the demolition of an existing fast-food restaurant and parking lot on the property. The Commission unanimously approved (4-0) the supplemental waiver requests as submitted. The request for architectural approval was tabled, also by a unanimous vote. The

Applicant was directed to return to the Commission with colored elevations for an alternate design, indicating the materials of the new scheme.

**ISSUES:** There are no outstanding issues.

**DRAFT MOTIONS:**

1. I move that the Planning Commission approve the architecture as submitted.

OR

2. I move that the Planning Commission forward the application to the May 15th Commission meeting for further discussion.

OR

3. I move an alternate motion.

**ATTACHMENTS:**

1. 2025.03.20 TOE P&Z Staff Report 8275 Ocean Gateway, paper copy & PDF
2. 2025.03.24 PC Outcome Letter - Zaxbys, paper copy & PDF
3. 2025.04.04 Zaxbys Revised Elevation, paper copy & PDF

EXTERIOR WALL FINISH					
EXTERIOR WALL FINISH	BR-01	BRICK	NICHIHA OR GLEN GERY THIN	#387 RUSTIC RED FLASHED THIN BRICK	BRICK MORTAR TO BE GLEN GERY G-501
EXTERIOR WALL FINISH	EIFS-01	EIFS STUCCO	PAREX	WATERMASTER	PAINTED PT-12
EXTERIOR WALL FINISH	EIFS-02	EIFS STUCCO	PAREX	WATERMASTER	PAINTED PT-10
EXTERIOR WALL FINISH	FC-01	BOARD & BATTEN SIDING	HARDIE PLANK		PAINTED PT-10
EXTERIOR WALL FINISH	FC-01a	FIBER CEMENT TRIM	HARDIE PLANK		PAINTED PT-10
EXTERIOR WALL FINISH	MP-01	METAL PANEL	PAC CLAD	SNAP CLAD - METAL ROOFING PANELS - FACTORY PAINTED FOUNDERS BLUE	CONTACT: CAM METAL - STEVE GLASENAPP - PHONE (262) 232-3200
EXTERIOR WALL FINISH	PT-10	PAINT	SHERWIN WILLIAMS	CUSTOM PAINT COLOR - ZAXBYS FOUNDERS BLUE - MATTE FINISH	PRIMER: PREPRITE PROBLOCK INTERIOR/EXTERIOR CONTACT: KATRINA PARTEE - PHONE (404) 323 2263 EMAIL: KATRINA.D.PARTEE@SHERWIN.COM
EXTERIOR WALL FINISH	PT-11	PAINT	SHERWIN WILLIAMS	CUSTOM PAINT COLOR - ZAXBYS TONGUE TORCH RED - SATIN FINISH	PRIMER: PREPRITE PROBLOCK INTERIOR/EXTERIOR CONTACT: KATRINA PARTEE - PHONE (404) 323 2263 EMAIL: KATRINA.D.PARTEE@SHERWIN.COM
EXTERIOR WALL FINISH	PT-12	PAINT	SHERWIN WILLIAMS	SW 7005 PURE WHITE. SATIN FINISH	PRIMER: PREPRITE PROBLOCK INTERIOR/EXTERIOR CONTACT: KATRINA PARTEE - PHONE (404) 323 2263 EMAIL: KATRINA.D.PARTEE@SHERWIN.COM
EXTERIOR WALL FINISH	PT-13	PAINT	SHERWIN WILLIAMS	SW 7069 IRON ORE - SATIN FINISH	PRIMER: PREPRITE PROBLOCK INTERIOR/EXTERIOR CONTACT: KATRINA PARTEE - PHONE (404) 323 2263 EMAIL: KATRINA.D.PARTEE@SHERWIN.COM
MECHANICAL ROOF SCREEN					
MECHANICAL ROOF SCREEN	SC-01	METAL SCREEN	CITADEL	CR-AX6 - HORIZONTAL REVEAL MOLDINGS FACTORY PAINTED FOUNDERS BLUE	CONTACT: CAM METAL - STEVE GLASENAPP - PHONE (262) 232-3200
ROOFING					
ROOFING	MP-02	METAL PANEL	PAC CLAD	SNAP CLAD - METAL ROOFING PANELS - FACTORY PAINTED FOUNDERS BLUE	GC TO PROVIDE MATCHING RIDGE VENT AND SNOWICE GUARDS AS SHOWN TO BE PAINTED PT-10. CONTACT: CAM METAL - STEVE GLASENAPP - PHONE (262) 232-3200
ROOFING	MP-03	METAL PANEL	PAC CLAD	METAL WALL PANEL - FLUSH AND REVEAL WALL PANELS - FACTORY PAINTED TONGUE TORCH RED	7" REVEALS - VERTICAL PANELS AT CORAL CONTACT: CAM METAL - STEVE GLASENAPP - PHONE (262) 232-3200
ROOFING	MT-01	COPING	METAL ERA	METAL COPING AND TRIM PERMA TITE FACTORY PAINTED FOUNDERS BLUE OR TONGUE TORCH RED	CONTACT: CAM METAL - STEVE GLASENAPP - PHONE (262) 232-3200
ROOFING	MT-02	GUTTER	BY G.C.	METAL SCUPPER AND DOWNSPOUTS - FACTORY PAINTED FOUNDERS BLUE	CONTACT: CAM METAL - STEVE GLASENAPP - PHONE (262) 232-3200
ROOFING	MT-03	METAL TRIM	METAL ERA	METAL AWNINGS/EYEBROW - ANCHOR TITE 8.5"	FACTORY PAINTED. CANOPY SUPPLIER TO PURCHASE ACM FROM METAL ERA PER ZAXBYS DESIGN STANDARDS. CONTACT: CAM METAL - STEVE GLASENAPP - PHONE (262) 232-3200
STOREFRONT					
STOREFRONT	SF-01	STOREFRONT	KAWNEER	TRIFAB VERSAGLAZE 451T - ALUMINUM DARK BRONZE ANODIZED	CONTACT: QUALITY GLASS - PHONE (706) 548-4481 CONTACT: QUALITY GLASS - PHONE (706) 548-4481

- ### EXTERIOR ELEVATION KEYNOTES
1. LINE INDICATES PROPOSED GRADE/SIDEWALK ELEVATION - GENERAL CONTRACTOR TO PROVIDE ADEQUATE AND CODE COMPLIANT POSITIVE DRAINAGE AWAY FROM FACE OF PROPOSED BUILDING AS REQUIRED.
  2. THERMALLY BROKEN ANODIZED ALUMINUM STOREFRONT SYSTEM WITH 1" INSULATED GLAZING - ROD AND CAULK AROUND ENTIRE PERIMETER OF OPENING - REFER TO SHEET A501 FOR INSTALLATION REQUIREMENTS OF CHICKEN FILM GRAPHICS PER CLIENTS DESIGN DIRECTIVE.
  3. PREFINISHED METAL WINDOW SILL FLASHING AS PER WINDOW MANUFACTURERS RECOMMENDATIONS.
  4. DOOR HANDLES TO BE PELLET ICE BLUE.
  5. INSULATED HOLLOW METAL DOOR AND FRAME - ROD AND CAULK AROUND ENTIRE PERIMETER OF OPENING - REFER DOOR SCHEDULE FOR FINISH REQUIREMENTS.
  6. GENERAL CONTRACTOR TO PROVIDE CONTROL JOINTS ALONG THIN BRICK INSTALLATION BASED ON MANUFACTURERS RECOMMENDATIONS.
  7. PREFINISHED METAL CAP FLASHING.
  8. BUILDING SIGNAGE IS FOR REFERENCE PURPOSES ONLY AND ARE TO BE SUBMITTED, REVIEWED, INSTALLED AND INSPECTED UNDER A SEPARATE PERMIT SUBMITTAL.
  9. EXTERIOR SHIPS ROOF LADDER.
  10. ELECTRICAL METER, MDP AND PANEL LOCATION - REFER TO ELECTRICAL FOR ADDITIONAL INFORMATION.
  11. PREFINISHED METAL CANOPIES WITH INTEGRAL LIGHTING.
  12. PREFINISHED ALUMINUM PASS-THRU WINDOW WITH INTEGRATED INTERIOR AIR CURTAIN - ROD AND CAULK AROUND ENTIRE PERIMETER OF OPENINGS.
  13. EIFS DECORATIVE REVEAL - REFER TO MANUFACTURERS GUIDELINES FOR PROPER INSTALLATION.
  14. KNOX BOX LOCATION - MOUNT @ 5'-0" AFF 0 VERIFY EXACT LOCATION WITH LOCAL AUTHORITIES PRIOR TO DOOR BELL LOCATION - GENERAL CONTRACTOR TO PROVIDE: EDWARDS SIGNALING, MODEL #AC 340-4N5.
  15. DASHED LINED INDICATED LOCATION OF CONCEALED BLUE LIGHTING TRIM AT GABLE AND DOWN SIDE OF BUILDING. REFER TO ELECTRICAL FOR ADDITIONAL INFORMATION.
  16. WALK-UP DIGITAL MENU BOARD LOCATIONS - THREE (3) IN TOTAL - PROVIDED BY STRATACACHE - REFER TO FOR ADDITIONAL INFORMATION.
  17. NOT USED
  18. NOT USED
  19. PREFINISHED ALUMINUM MECHANICAL SCREENING ELEMENT.
  20. PREFINISHED METAL DOWNSPOUT AND GUTTER SYSTEM - FINISH OF METAL TO MATCH ADJACENT FINISH.

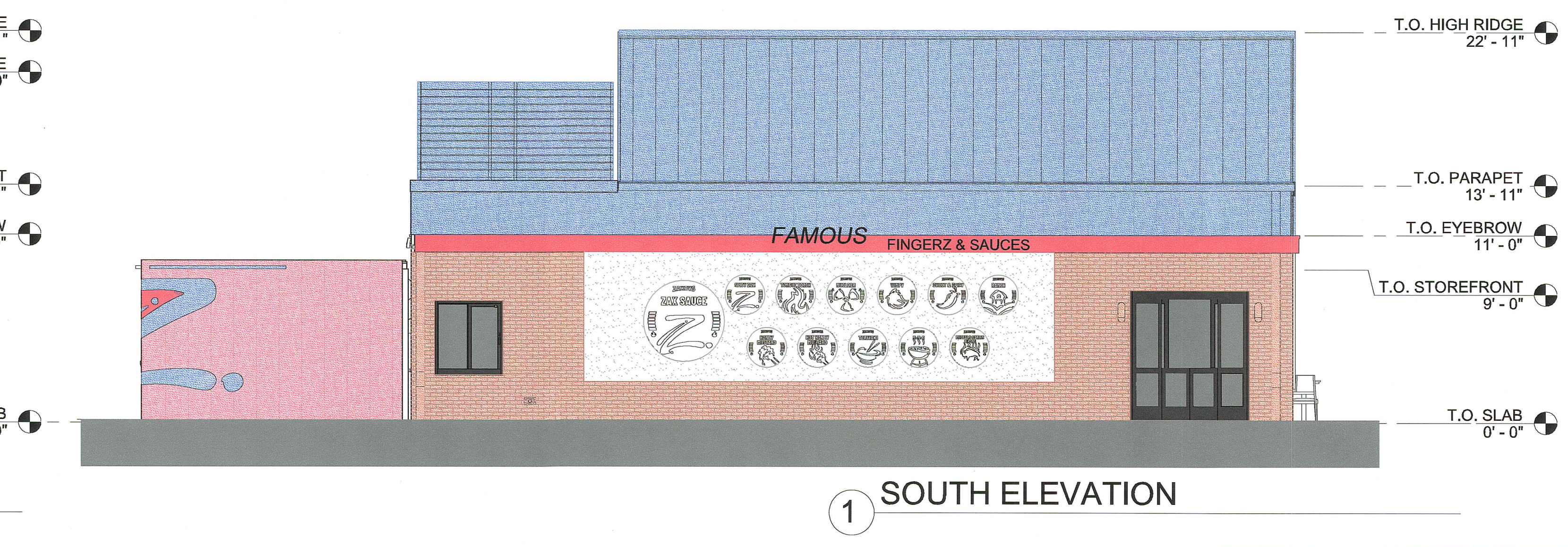
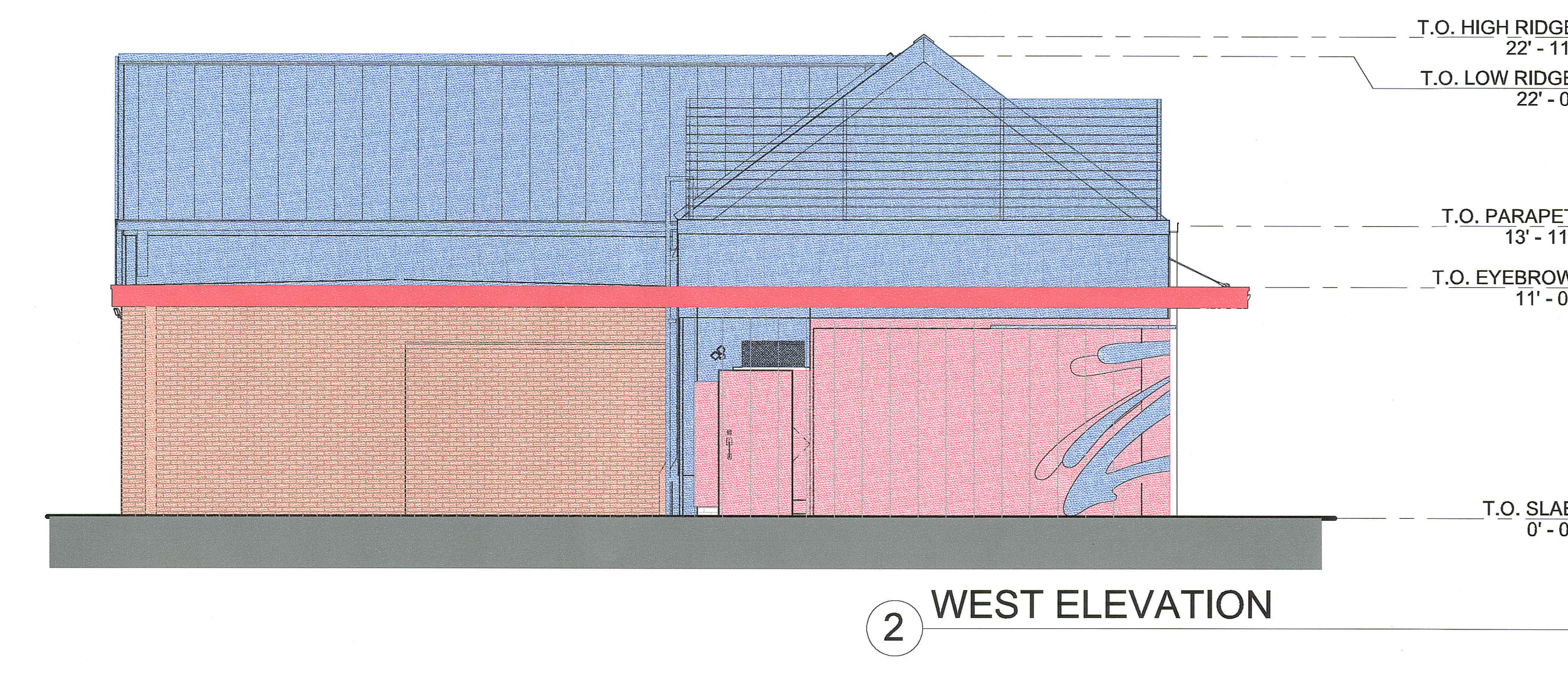
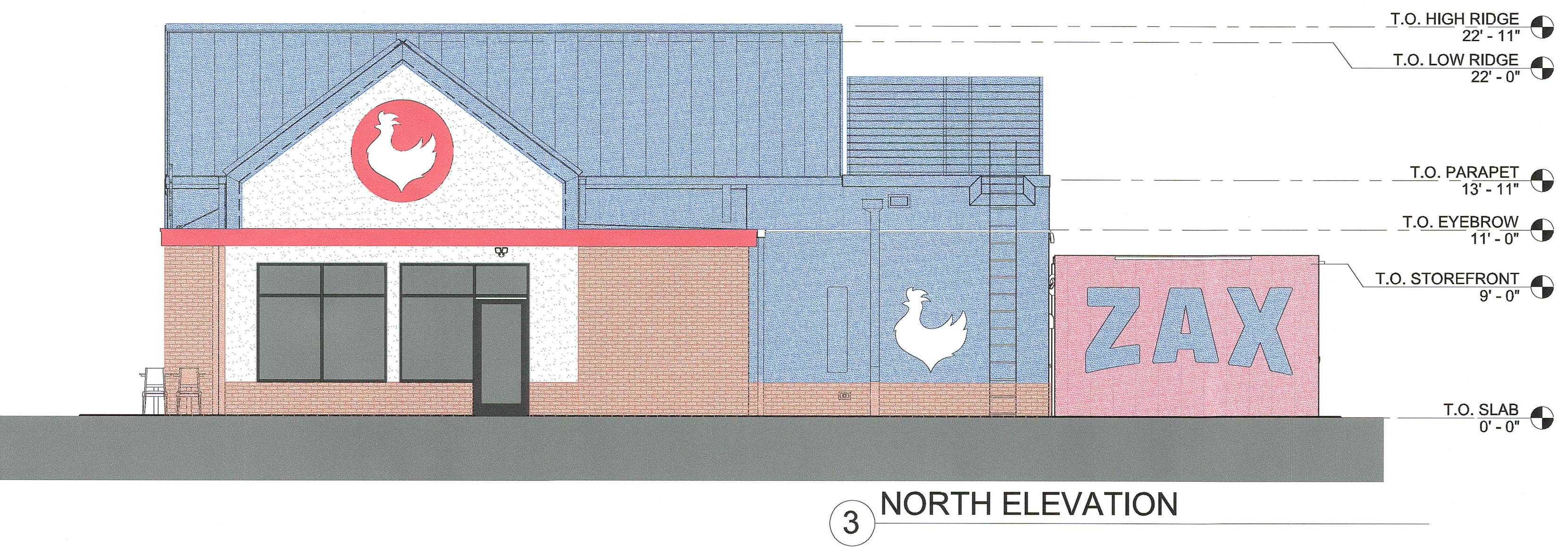
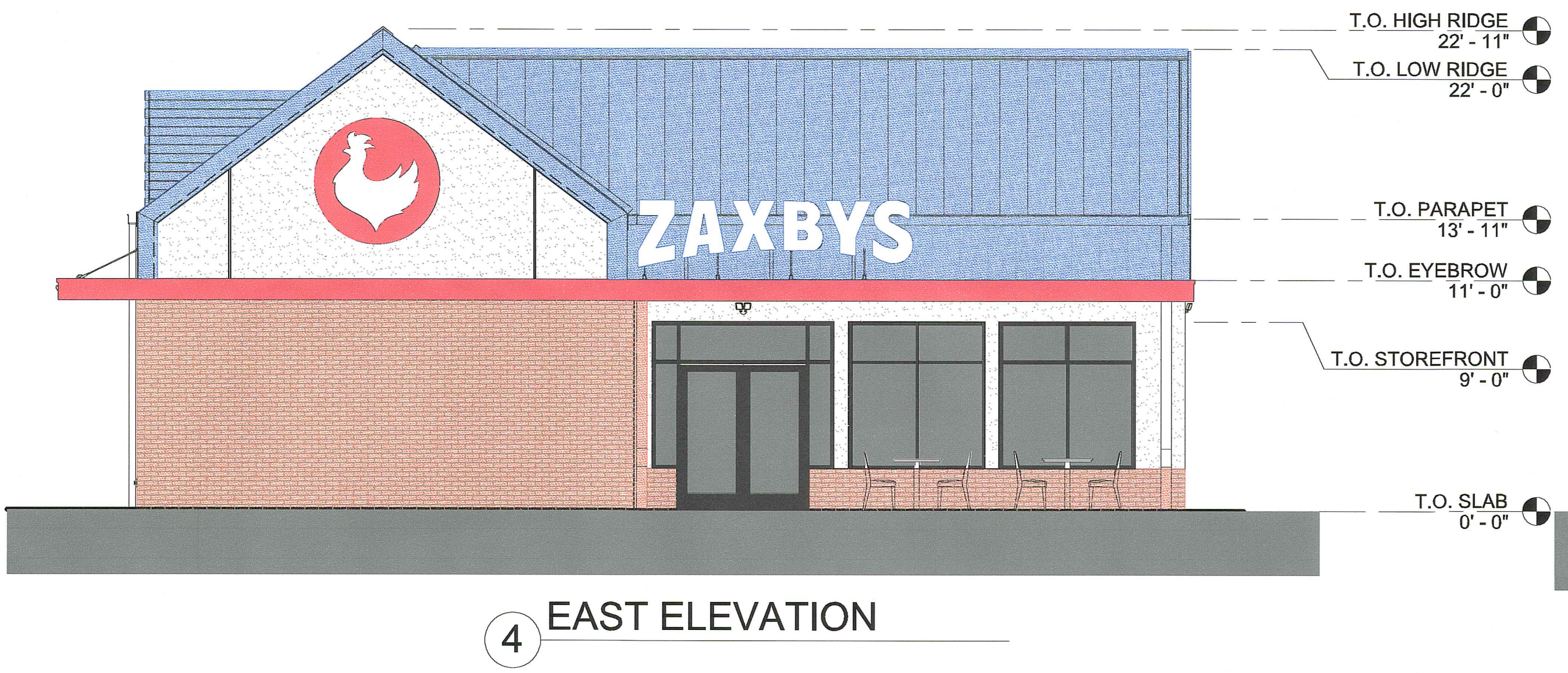

**ZAXBYS**  
8275 OCEAN GATEWAY  
EASTON, MARYLAND 21601

**ZAXBYS**

Scale 1/4" = 1'-0"

Date 4 APR, 2025 Drawn by C.W.

Job Number 25 3756 Checked by C.W.

**EXTERIOR ELEVATIONS**

**A201**

PROFESSIONAL CERTIFICATION PER MARYLAND STATE COMAR SECTION 09.21.02.04

I CERTIFY THAT THESE DOCUMENTS WERE PREPARED OR APPROVED BY ME AND THAT I AM A DULY LICENSED ARCHITECT UNDER THE LAWS OF THE STATE OF MARYLAND, LICENSE NO. 18344, EXPIRATION DATE: 03/11/2026



**TOWN OF EASTON**  
**PLANNING & ZONING**  
14 S Harrison Street, Easton MD 21601

**Date of Hearing: March 20, 2025**

**# 4c**

**PLANNING COMMISSION  
PUBLIC HEARING  
STAFF REPORT**

**SUBJECT:** 8275 Ocean Gateway - Zaxbys

**ELECTION WARD:** Ward 2

**CRITICAL ACTION DATE:** At the pleasure of the Commission

**STAFF CONTACTS:** Joseph Mayer, Plan Reviewer  
Miguel Salinas, Director of Planning and Zoning

**APPLICANT:** Delmarva Real Estate Management Group, LLC.% Curtis Syder, Esq.

**DOCUMENT CREATED ON:** March 3, 20025

**PURPOSE:** Delmarva Real Estate Management Group, LLC (Applicant), is seeking architectural approval for the construction of a Zaxbys fast-food restaurant with parking, stormwater management and landscaping. Associated site improvements include the demolition of an existing fast-food restaurant and parking lot on the property. In addition, the applicant is seeking a landscape and buffering waiver from Chapter 28-1014.6.E.1.and Chapter 28-1014.7.E.2.a & b of the Zoning Code.

**RECOMMENDATION:** Staff supports Planning Commission approval of the proposed site plan subject to staff's recommended condition (see below).

---

<b>APPLICATION INFORMATION:</b>	
<b>APPLICANT:</b> Delmarva Real Estate Management Group, LLC.% Curtis Snyder, Esq.	<b>REPRESENTATIVE:</b> Lane Engineering, LLC.: Brett Ewing Delmarva Real Estate Management Group, LLC.% Curtis Snyder, Esq.
<b>PARCELS/ACREAGE:</b>	
Parcel Information	Acreage
Map 103, Grid 0000, Parcel 2861	0.865
<b>ACCEPTANCE DATE:</b> March 3, 2025	<b>LOCATION:</b> 8275 Ocean Gateway
<b>EXISTING ZONING</b> CG	<b>EXISTING LAND USE:</b> Fast-food restaurant (Wendy's).
<b>HISTORIC DISTRICT:</b> Not Applicable	<b>FUTURE LAND USE MAP:</b> Commercial

**CONTEXT:**

Location/Site Access – The subject property is located along Ocean Gateway, fronting on the East side of the road.

Existing Conditions – The subject property is currently a closed fast-food restaurant (Wendy's).

Surrounding Properties

- 8289 Ocean Gateway - CG
- 29315 Matthewstown Road - CG
- 8265 Ocean Gateway - CG



*Figure 1: Vicinity Map*

**PROPOSAL:** The applicant, Delmarva Real Estate Management Group, LLC., is proposing to construct a new 2,005 square foot Zaxbys fast-food restaurant with parking, two-lane drive-thru, stormwater management and landscaping. The site improvements include the removal of an existing fast-food restaurant (Wendy’s) and parking lot on the property. Delmarva Real Estate Management Group, LLC. is seeking architectural approval.

The applicant is also seeking a landscape and buffering waiver from Chapter 28-1014.6.E.1 and Chapter 28-1014.7.E.2.a & b of the Zoning Code. The site is not currently in compliance with the landscaping code. The applicant proposes to add new landscaping, however, there are site limitations that prevent full compliance with §28-1014.6.E.1; overall trees total twenty-six (26) required plantings. The applicant is proposing twenty-four (24) trees which requires a waiver of two (2) trees. The applicant is seeking a waiver from the landscaping requirements along Route 50, as specified in §28-1014.6.E.2.a & b (Bufferyard ‘B’). Specifically, they are requesting to reduce the required buffer width from twenty-five feet (25') to twenty feet (20') and a waiver from the requirement for six canopy trees and three evergreen trees. Instead of the required trees, the applicant proposes four canopy trees and one evergreen tree and is requesting a waiver for the remaining two canopy trees and two evergreen trees.

**BACKGROUND:** The existing site is a commercial property currently utilized with a fast-food restaurant (Wendy’s). The applicant submitted an application to the Easton Staff Development Review Committee on February 26, 2025 (please see attached ESDR Determination Letter).

**ZONING ANALYSIS:**

**A. Permissible Land Uses**

**28-201 Table 2.1**

**CG**

227	Restaurant, Fast Food	--	--	--	--	SE	SE	SE	--	--		
-----	-----------------------	----	----	----	----	----	----	----	----	----	--	--

**Analysis** – The proposed project is presented and described by the Applicant as a fast-food restaurant. The project is categorized as “*Restaurant, Fast Food*”. The proposed use is permitted by Special Exception within Table 2.1 Table of Permissible Uses. Please note that the existing site is a fast-food restaurant and the proposed use is a continuation of the categorized use.

**B. Off-Street Parking**

For the purposes of off-street parking calculations, the use is considered “*Restaurant, Fast-Food*” and has the following requirements:

**28-1001.3 Parking Requirements**

	Use/Activity	Minimum Vehicle Spaces	Maximum Vehicle Spaces	Minimum Bicycle Spaces	Notes
<b>Commercial Buildings</b>					
26	Restaurant, Fast Food	1 per 100 sf GFA	1 per 50 sf GFA	1 per 10 vehicle spaces	Minimum 5 stacking spaces per drive-thru stall required.

**Total Site Parking Required:**

**Restaurant, Fast Food:** 1 per 100 sf GFA required-Minimum  
 2,005 sf/100 = 20 spaces required-Minimum  
 1 per 50 sf GFA required-Maximum  
 2,005 sf/50 = 40 spaces required-Maximum  
 Total spaces provided: 20

**Bicycle Spaces:** 1 per 10 vehicle spaces required  
 20 spaces/10 = 2 bicycle space-Minimum  
 Total bicycle spaces provided: 2

**Drive-thru:** 5 stacking spaces per drive-thru stall required-Minimum  
 5 spaces x 2 lanes = 10 spaces-Minimum  
 Total spaces provided: 18

**Analysis-** The applicant has provided twenty (20) off-street parking spaces that meet the minimum requirement. The proposed two-lane drive-thru exceeds stacking space requirements

and adequate off-street parking is available. The owner does not foresee a demand for more parking spaces in the future, due to the nature of their business operations.

**C. Commercial General District Development Standards**

<b>Table 1. Development Standards</b>		
<b>CG Zoning District</b>	<b>Standard</b>	<b>Proposed</b>
Setbacks	Front = 25 feet Side = 10 feet Rear = 15 feet	Front = 40 feet Side = 10 feet Rear = 15 feet
Lot Size (min.)	20,000 square feet	37,670 square feet
Lot Frontage (min.)	60 feet	213 feet
Building Envelope (min.)	20 feet x 30 feet	139 feet X 178 feet
Lot Coverage (max.)	50% (Lot Area)	9.5% (Lot Area)
Height (max.)	50 feet	Not to exceed 50 feet
Bufferyard	Per the provisions of Section 28-1014 of the Zoning Ordinance.	To be provided along Route 50. (Waiver requested)

**§ 306.2 of the Zoning Ordinance states that development within the Commercial General District shall also meet these additional requirements:**

- ***Off-Street Parking shall be provided for all uses in accordance with the standards of Section 28 – 1001.***
- ***All on-site lighting unless approved otherwise by the Planning and Zoning Commission shall be low cut-off shielded luminaries at 18’ height and light shall not shine off-site at levels greater than 1-foot candle.***
- ***All off-street loading and unloading areas shall be screened from view by permanent decorative screens or natural planting, either of which shall be a minimum of eight (8) feet in height.***
- ***All areas not devoted to buildings or parking areas shall be landscaped and maintained in a suitable manner, in accordance with the provisions of Section 28 – 1014 of this Ordinance.***

**Analysis** - The site falls under the CG - Commercial General District Area and meets the § 28-306 Development Standards. The applicant is requesting a landscape waiver from Chapter 28-1014.6.E.1 and Chapter 28-1014.7.E.2.b of the Zoning Code. Any comments or concerns from the ESDR review letters will be addressed during the Development Site Plan review.

## D. Forest Conservation

*The Easton Forest Conservation Requirements of the Town Code, Article III, § 31-3.1 Relevance, states that the requirements are applicable to any person making application for a subdivision, project plan, grading, or sediment and erosion control approval on units of land 40,000 square feet or greater after the effective date of the Ordinance.*

**Analysis** - The development of this site is within the priority funding area that's within the proximity of established businesses. The overall site area is 37,670 square feet and is under the required 40,000 square foot minimum. Therefore, Forest Conservation is not required.

### POLICY ANALYSIS:

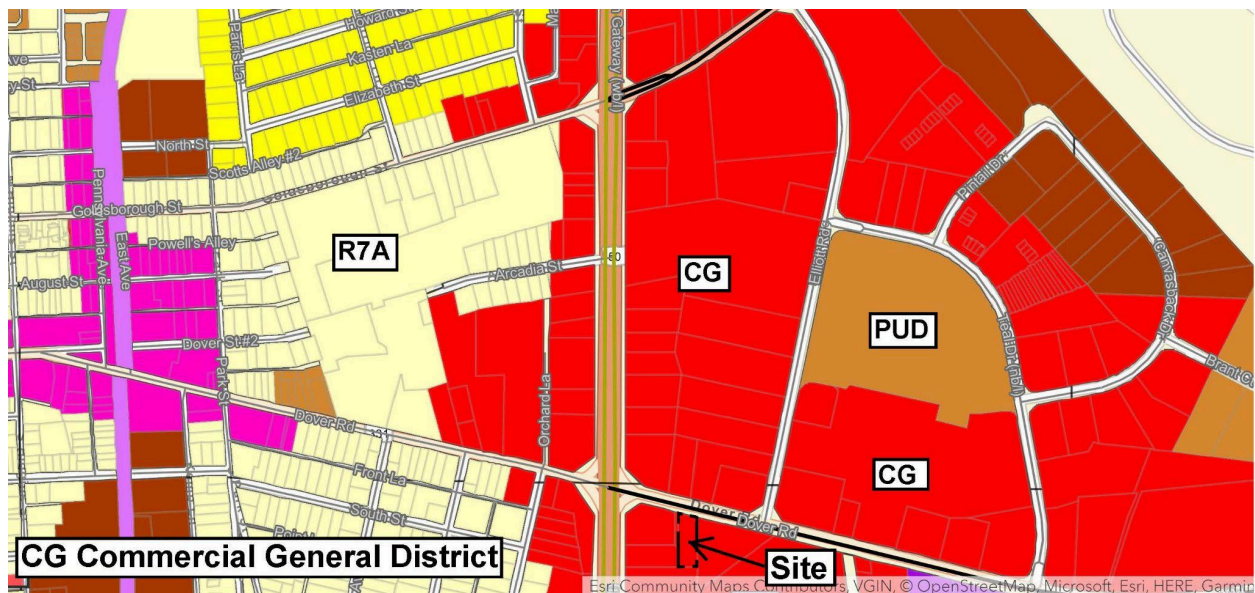

*Figure 2: Zoning Map*

*The submission of a site plan for a proposed use or development activity shall not be approved unless it meets the factors below:*

*1. The site plan meets the design principles and standards and required improvements set forth in this Ordinance, the Town Comprehensive Plan, the Town of Easton Subdivision Regulations, and other ordinances, regulations, and policies established by the Town of Easton.*

**Town of Easton 2010 Comprehensive Plan Design Principles (Principle #1) Integrated uses are desirable-** Applicant's response: *This plan proposes to redevelop a site that is currently utilized as a fast-food into another fast-food restaurant. This use is especially prevalent along the Route 50 corridor.*

*Staff notes that the proposed development fits within the general commercial nature of Rote 50.*

**(Principle #2) Natural features should determine design** – *Applicant's response: The proposed development intends to mimic the existing boundaries of the parking lot in order to avoid adding impervious areas and also includes the mitigation of stormwater that was not previously integrated on site.*

*Staff notes that there are no compelling natural features on site.*

**(Principle #3) Automobiles should not determine design** – *Applicant's response: N/A to drive-thru restaurant permitted in the CG District.*

*Staff notes that the applicant has provided 20 off-street parking spaces in addition to the drive-thru parking. They are providing the minimum number of required spaces and nearly double the stacking space required for the drive-thru windows. This would seem to be an effort to accommodate automobiles without allowing them to dominate the design of the site..*

**(Principle #4) Ample Open Space should be provided within & around neighborhoods** – *Applicant's response: N/A.*

*Staff notes that open space is not applicable.*

**(Principle #5) Architecture should respect Easton's Historical Development** – *Applicant's response: This application proposes architecture improvements compatible with existing Route 50 corridor improvements.*

*Staff notes that the proposed building is comparable and consistent to the architecture along the US Route 50 corridor. It should also be noted that the discussion of this Design Principle is where one will find the statement that often guides the Commission's review of commercial architecture, "One thing that is clearly not welcome in Easton is generic, corporate franchise architecture." The applicant is clearly proposing a building that represents Zaxby's corporate architecture, albeit a relatively new one and, obviously, one which at least initially will be somewhat unique with only two other Eastern Shore franchises planned (at the moment) for Berlin and Cambridge.*

*The intent of this language is to ensure that commercial buildings in Easton are unique and of a character appropriate and befitting Easton. The Commission has previously been satisfied that this criteria can be met with modest elevation and/or material changes.*

**(Principle #6) Signs should inform but not dominate** – *Applicant's response: Signage will comply with base zoning requirements.*

*Staff notes that any proposed monument sign will require a Signage Application to be submitted prior to installation. Signs should inform but not dominate the area.*

**(Principle #7) Neighborhoods should contain a diversity of housing types – Applicant’s response:** *Not applicable to this application.*

**(Principle #8) Residential neighborhoods should be interesting places – Applicant’s response:** *Not applicable to this application.*

**(Principle #9) Neighborhoods should connect – Applicant’s response:** *Not applicable to this application.*

**2. The site plan avoids or minimizes adverse impacts upon features (whether on-site or off-site) of historical, cultural or ecological significance.**

**Analysis** - The proposed site is not within the Historic District or the Critical Area. This project would provide a new 2,005 square foot fast-food restaurant with improved amenities; adequate parking and landscaping.

**3. The proposed use or development activity will not substantially increase traffic hazards due to traffic generated by the proposed use, the location of curb cuts or the layout of internal traffic circulation.**

**Analysis** - The two-lane drive-thru exceeds stacking space requirements and adequate off-street parking is available. The proposed use and activity will not create traffic hazards in the surrounding area.

**4. The site plan and the proposed use or uses do not cause any adverse impact upon the health or safety of persons residing or working in the area surrounding the site or upon the character of the neighborhood surrounding the site; and**

**Analysis** - There would be no adverse impacts. The existing property is located within a commercial general zoned district. Proposed use provides a 2,005 square foot fast-food restaurant with adequate parking, SWM and landscaping features.

**5. The site plan improves the water quality of the Chesapeake Bay or its tributaries.**

**Analysis** - The proposed site would meet required design practices for stormwater management.

## **E. Supplemental Waiver Request: Landscaping & Buffering**

### **28-1014.6.E.1 LANDSCAPE IMPROVEMENTS**

*Overall minimum tree plantings required (excluding required bufferyards) shall be based on site area to be disturbed. (Disturbed area includes all site areas except for existing forest retention and preservation, existing wetland preservation, significant non bufferyard areas of larger sites to be preserved in a natural state, and required bufferyard areas. The minimum tree requirement shall be:*

*a. Disturbed area up to 11,00 sq. ft.                      1 tree/1000 sq. ft.*

11,001 to 100,000 sq. ft.  
>100,001 sq. ft.

1 tree/1500 sq. ft.  
1 tree/2500 sq. ft.

## **28 – 1014.7.E.2(b) BUFFERYARD STANDARDS**

2. Bufferyard 'B' (for non-residentially zoned lots or land use applications to buffer Major Roads as described in Zoning Ord., Sec. 28 – 1010).

- a. 25' width
- b. Plant unit:  
2 shade/canopy trees and 1 evergreen tree
- c. Options:
  1. Average 3' berm, reduce evergreen tree height to 5'
  2. Substitute 1.5 understory trees for 1 evergreen tree for maximum 50% of required evergreen trees.

**Analysis** - The applicant has requested a landscape and buffering waiver from Chapter 28-1014.6.E.1 and Chapter 28-1014.7.E.2.b of the Zoning Code. The application notes that the site is currently not compliant with the landscaping code. They propose to add new landscaping, however, there are site limitations that prevent full compliance with §28-1014.6.E.1; overall trees total twenty-six (26) required plantings. The applicant is proposing twenty-four (24) trees which requires a waiver of two (2) trees. The applicant has requested a waiver from the landscaping requirements along Route 50, as specified in §28-1014.6.E.2.a & b (Bufferyard 'B'). Specifically, they are requesting to reduce the required buffer width from twenty-five feet (25') to twenty feet (20') and a waiver from the requirement for six canopy trees and three evergreen trees. Instead of the required trees, the applicant proposes four canopy trees and one evergreen tree and is requesting a waiver for the remaining two canopy trees and two evergreen trees.

The applicant's modified design for redevelopment of an existing fast-food restaurant adheres to the spirit and intent of the Bufferyard and required tree plantings, while also capturing the overall design. Due to site limitations such as lot size, parking, and SWM requirements, certain landscape requirements cannot be met. Staff supports the waiver request for the modified Bufferyard "B" along Ocean Gateway and the overall minimum tree plantings required.

### **RECOMMENDED CONDITION:**

Staff recommends the Planning Commission approve the proposed architecture and landscape waivers from Chapter 28-1014.6.E.1 and Chapter 28-1014.7.E.2.b of the Zoning Code with the following condition:

- The applicant is to address all remaining ESDR review comments and submit a Development Site Plan for review.
- Coordinate with the Talbot County Health Department and Building Inspection Division for all applicable permits prior to construction.

**DRAFT MOTIONS:**

1. I move that the Planning Commission approve the sketch site plan subject to staff's Condition of Approval.

OR

2. I move that the Planning Commission table the application to the April 17th Commission meeting for further discussion.

OR

3. I move an alternate motion.

**ATTACHMENTS:**

1. 2025.02.05 Concept SWM Report, paper copy & PDF
2. 2025.02.05 ESDR Application, paper copy & PDF
3. 2025.02.05 Site Plan Application, paper copy & PDF
4. 2025.02.26 ESDR Determination Letter 8275 Ocean Gateway, paper copy & PDF
5. 2025.03.03 Building Renderings, paper copy & PDF
6. 2025.03.03 Waiver Request, paper copy & PDF
7. 2025.03.03-Sketch Site Plan, paper copy & PDF
8. 8275 Ocean Gateway (Zaxbys) - PC 400' Notice Letter, paper copy & PDF
9. 8275 Ocean Gateway (Zaxbys) - Subject Property Notice 2025.03.04, paper copy & PDF



**TOWN OF EASTON**  
**Planning & Zoning Department**  
P.O. Box 520  
Easton, Maryland 21601

March 24, 2025

Lane Engineering LLC  
% Brett Ewing  
117 Bay Street  
Easton, Maryland 21601

**Re: Application 2025 - 1391 / W 25 - 02**  
8275 Ocean Gateway - Zaxbys  
Tax Map 0103, Grid 00EA, Parcel 2861  
Easton, Maryland 21601

Mr. Ewing:

At their regularly scheduled meeting on March 20, 2025, the Town of Easton Planning Commission (Commission) reviewed the above application to request architectural approval for the redevelopment of the existing property at 8275 Ocean Gateway with associated site improvements, and a supplemental waiver request from the minimum landscape and bufferyard requirements of Section 28-1014.6.E.1, and Section 28-1014.7.E.2.a & b of the Zoning Code.

The Commission voted 4 - 0 to approve the supplemental waiver requests as submitted.

The Commission also voted 4 - 0 to table the request for architectural approval. The Applicant shall return to the Commission with colored elevations for an alternate design. The elevations shall indicate the materials of the new scheme.

Any person aggrieved by this decision may, within thirty (30) days of the Planning Commission's decision, file an appeal with the Town Planner and with the Board of Zoning Appeals specifying the grounds thereof. Should you have questions concerning the above finding, please contact this office at 410-822-1943.

Sincerely,

*Samantha N. Smith*

**Samantha N. Smith**, Administrative Specialist  
Planning & Zoning Department  
410-822-1943 [ssmith@eastonMD.gov](mailto:ssmith@eastonMD.gov)

CC: Curtis Snyder, Esq., Delmarva Real Estate Management Group LLC



## TOWN OF EASTON

14 South Harrison Street  
Easton, Maryland 21601

April 2, 2025

Dear Resident,

The Easton Planning Commission (Commission) will hold a public meeting on **Thursday, April 17, 2025 at 1:00 p.m.** in the Easton Town Council Chambers located on the second floor of 14 South Harrison Street. The Town of Easton Zoning Ordinance requires that owners of property located within 400 feet of a parcel on which certain types of applications are pending be given notice of upcoming meetings or hearings. If you are a tenant in or an owner of a multi-unit building, please distribute or post this notice in a visible location for all other tenants or owners to view. If you are a tenant of a rental property, please notify the property owner that this notice letter has been distributed to their property. Notice has also been sent to the Star Democrat, a sign has been posted at the subject property and the hearing agenda has been posted on the Town of Easton website: <http://eastonmd.gov/>.

This letter is sent to inform you that Lane Engineering LLC (Applicant) has filed application 2025 - 1391 on behalf of Delmarva Real Estate Management Group, LLC (Owner) to request architectural approval for the redevelopment of the existing property and structure to be converted to a fast-food establishment (Zaxbys). This is a continuation of the March 20, 2025 Planning Commission meeting. The Applicant has since received a supplemental waiver from the minimum landscaping and bufferyard requirements of Section 28-1014.6.E.1 and Section 28-1014.7.E.2.a&b of the Town of Easton Zoning Code. The property is located at 8275 Ocean Gateway, also known as Tax Map 0103, Grid 00EA, Parcel 2861, Lots 10-13.

Copies of the proposed application are on file and available for public review in the Town's Planning Office at 14 South Harrison Street between the hours of 8:30 a.m. and 4:00 p.m., Monday through Friday. **In addition, digital copies will be available for review one week prior to the scheduled meeting via the Town's website at <https://www.eastonmd.gov/129/Agendas-Minutes>.** If you have any questions regarding this application, please contact the Planning Office at (410) 822-1943 or via email at [ssmith@eastonMD.gov](mailto:ssmith@eastonMD.gov).

*Samantha N. Smith*

Samantha N. Smith, Administrative Specialist  
Planning & Zoning Department  
410-822-1943 [ssmith@eastonMD.gov](mailto:ssmith@eastonMD.gov)



***Subject property posting pursuant to Section 28-901.2.H.2 of the Town of Easton Zoning Code - March 31, 2025***

# East End Design

A new way to administer Traditional Village Planning



1

Jay Corvan Architect , 4/25

## What we are trying to accomplish :

1. Better ways to preserve what Easton's economy runs on: Community character
2. Better ways to speed the approval process with much clearer communities through graphic means.
3. Better ways to communicate with developers what we as a community want , before they even start their design process and go off on a tangent.
4. Better ways to keep legal fights and confrontations from occurring



## Problem areas : public process

1. The Easton Zoning in the East End via The new PRD Ordinance now allows 40 units per acre, an increase in density. This is a good idea but needs better implementation and limitations.
2. The very few other restrictions designated to this PRD zone makes community participation mandatory, and places a burden on the public.
3. The recent “Primrose” project took four different attempts to pass the PC. It took a lot of community interaction to wrestle the project to a suitable result.
4. What happens when the community gets tired of showing up? We get a different compromised result.



Graphics by UDA

## Why Form Base Zoning Works Better:

- . If the applicant follows the basic sheet format, the application will be given the fastest approval possible. SPEED
- . This will raise the quality of applications and allow for less community push back, all have a better result than the current system, it all operates on expectation.
- . The system is designed to create better applications in the beginning and not create so many re-applications, and to create new projects that model existing community character, and to have a sort of “*pre -approval* “of the community about what it expects. Its establishes a better starting point.

This approach is also good for a developer because they can expect quick approval if the project tracks in the standard form based compliance.





Form based zoning can avoid these problems by:

- . Will not allow projects to over build certain densities.
- . Will not allow over building in spot areas
- . Will not allow alien building types to be in a misplaced in a zone.
- . Will not create community dissatisfaction. Many of the building types and densities are community pre-approved .



## Problem Areas : Where Infill can go wrong:

- 1) Improper Scale ,
- 2) Too much density,
- 3) mismatch of community types,
- 4) misunderstood community character
- 5) invasion of outside elements traffic)

Graphics by Jay Corvan  
Architect

# 1. Community Character: How can we protect it ?

- a. Better ways to preserve what Easton's economy runs on: Community character ?
- b. How can we protect it ?
- c. Is it our job to protect and defend community character, per comp plan ?
- d. Who cares and what stake do they have in the the outcome, neighborhood and public involvement ?



2.

Better ways to speed the approval process with much clearer communities through graphic means.

. How long does it take now ....too long

How can we improve this procedure ..too unpredictable ...use better models

. How can we measure it ...try it and see measure it after in use for one year.

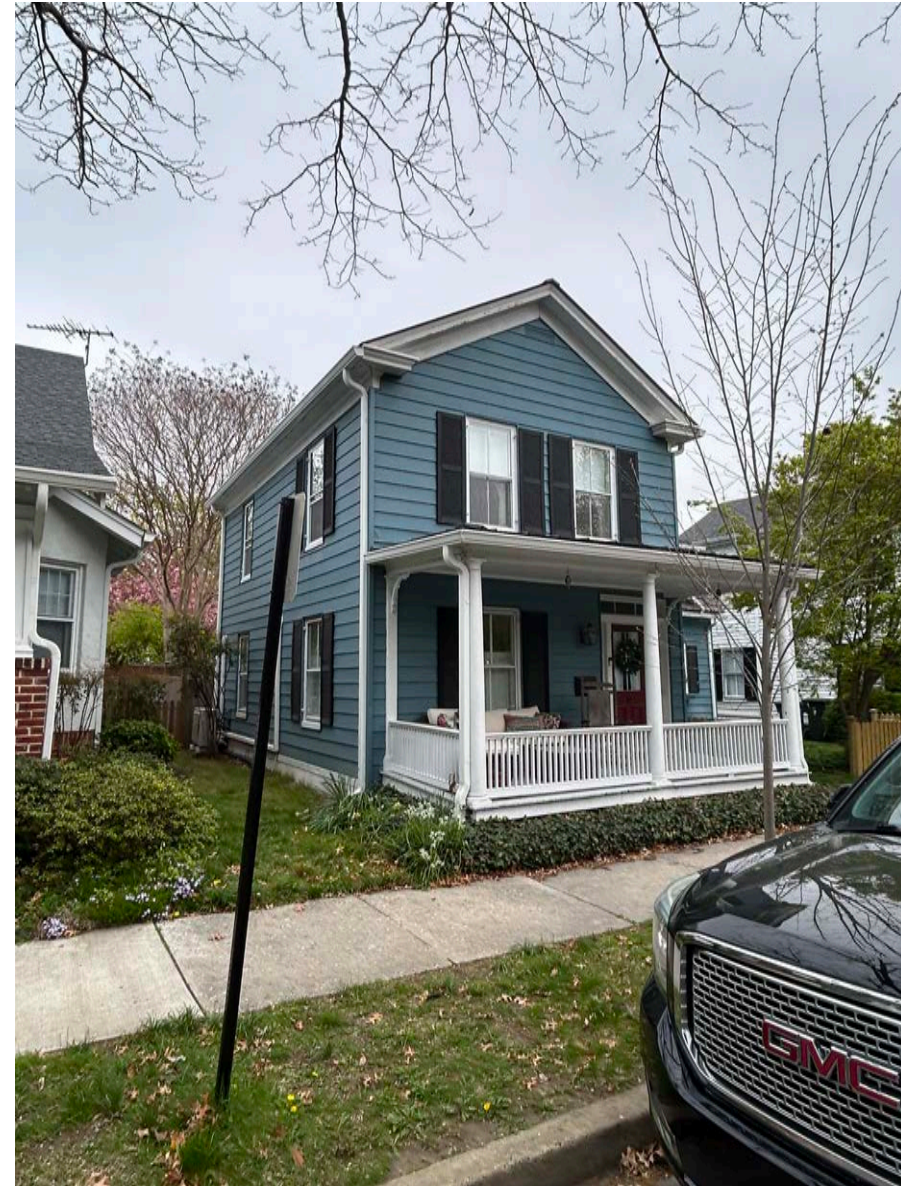

### 3. Better ways to communicate / efficiency

- . A better way to communicate to developers what we as a community wants
- . A better way to improve the quality of applications
- . A better way that translates into savings to the City Planning staff , less push back from citizens, less time and difficulty in the review process at the PC.





4. What we are trying to accomplish :

Better ways to keep legal fights and confrontations from occurring

Litigation to be avoided costly to the city and costly to the citizen base that has to fund it privately.

We are trying to simplify the application process.... Simplify the staff and PC portions of the application process by directing design through:

- 1) transect ,
- 2) use,
- 3) bldg. type,
- 4) building detail

### Page 1: Transect/ Density

#### The Transect of Denton

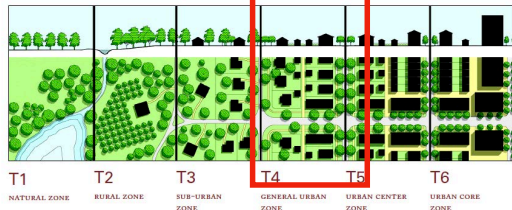

Where are you in the city  
What transect

### Page 2: allowed use

#### Building Types and the Transect

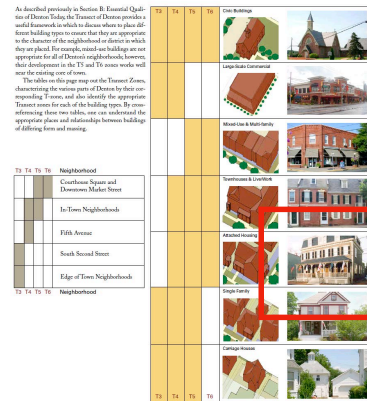

What are you building  
What is the use

### Page 3: Local Type

#### BUILDING TYPOLOGY : Large Avenue Houses Avenue Typology Transects 3 - 5, Easton Maryland



This is what it should look like

### Page 4: Project Details

#### Windows and Doors



Here are the Appropriate details

## How Form Base Zoning works

FIRST.....Where is project located ( per village density region) T1- T6.

SECOND..... What is the use of the project ( see permitted building use diagram)

THIRD.....What are the building types allowed ( see building type diagram per use )

FOURTH ....What are the suggested building details for that building type ( see detail sheets )



Graphics by UDA

# The Transect of Denton

Graphics by UDA



T1

NATURAL ZONE

T2

RURAL ZONE

T3

SUB-URBAN  
ZONE

T4

GENERAL URBAN  
ZONE

T5

URBAN CENTER  
ZONE

T6

URBAN CORE  
ZONE

## STEP ONE : Establish Density Zone ( T1-T6 )

This density map has yet to be done for Easton

## Building Types and the Transect

As described previously in Section B: Essential Qualities of Denton Today, the Transect of Denton provides a useful framework in which to discuss where to place different building types to ensure that they are appropriate to the character of the neighborhood or district in which they are placed. For example, mixed-use buildings are not appropriate for all of Denton's neighborhoods; however, their development in the T5 and T6 zones works well near the existing core of town.

The tables on this page map out the Transect Zones, characterizing the various parts of Denton by their corresponding T-zone, and also identify the appropriate Transect zones for each of the building types. By cross-referencing these two tables, one can understand the appropriate places and relationships between buildings of differing form and massing.

T3	T4	T5	T6	Neighborhood
				Courthouse Square and Downtown Market Street
				In-Town Neighborhoods
				Fifth Avenue
				South Second Street
				Edge of Town Neighborhoods

T3 T4 T5 T6 Neighborhood

Graphics by UDA

T3	T4	T5	T6	Building Type	Image
				Civic Buildings	
				Large-Scale Commercial	
				Mixed-Use & Multi-family	
				Townhouses & Live/Work	
				Attached Housing	
				Single Family	
				Carriage Houses	

## STEP TWO : Establish Building Type:Density Zone ( T1-T6 )

This density map has yet to be done for Easton

b. BUILDING TYPE by T area

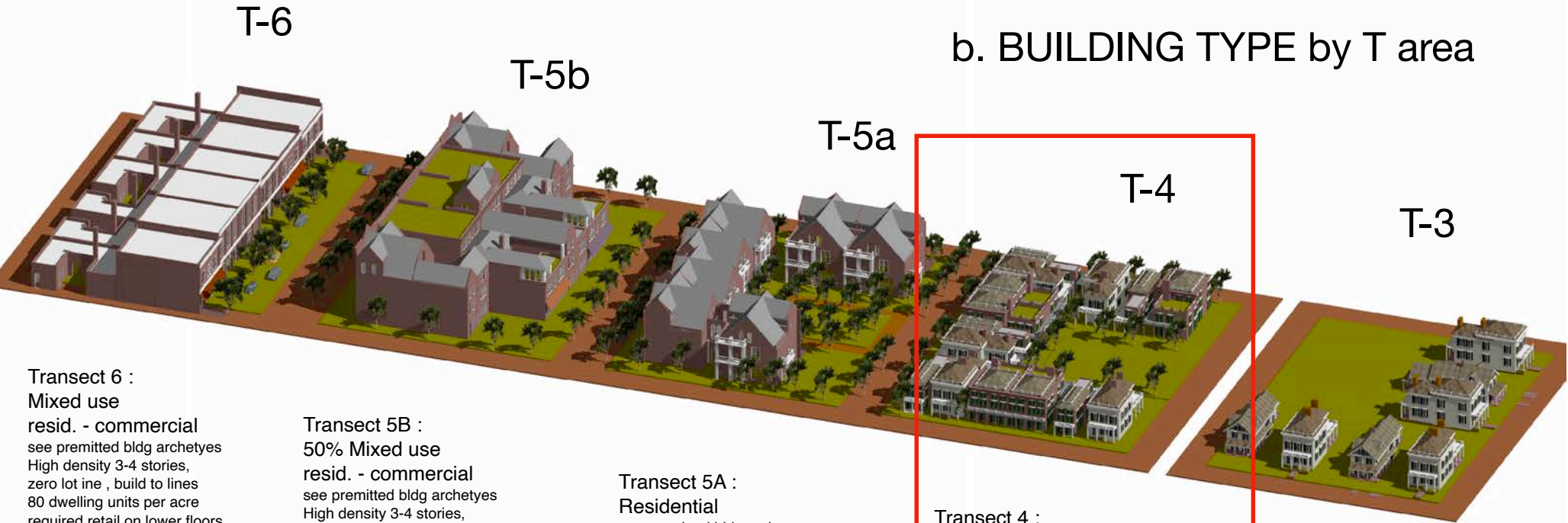

**Transect 6 :**  
**Mixed use**  
 resid. - commercial  
 see permitted bldg archetypes  
 High density 3-4 stories,  
 zero lot ine , build to lines  
 80 dwelling units per acre  
 required retail on lower floors  
 brick exterior, cornices,  
 historic window deails  
 sidewalk and planting req.  
 light and ventilation req.  
 roof terraces, energy req.

**Transect 5B :**  
**50% Mixed use**  
 resid. - commercial  
 see permitted bldg archetypes  
 High density 3-4 stories,  
 zero lot ine , build to lines  
 80 -100 dwelling units per acre  
 possible retail office on lower floors  
 brick exterior, cornices,  
 historic window deails  
 sidewalk and planting req.  
 natural light and ventilation req.  
 roof terraces, energy req.  
 open public space 20% req.

**Graphics by Jay Corvan  
 Architect**

**Transect 5A :**  
**Residential**  
 see permitted bldg archetypes  
 High density 3-4 stories,  
 zero lot ine , build to lines  
 60- 80 dwelling units per acre  
 possible retail office on lower floors  
 brick exterior, cornices,  
 historic window deails  
 sidewalk and planting req.  
 natural light and ventilation req.  
 roof terraces, energy req.  
 open public space 20% req.

**Transect 4 :**  
**Residential**  
 see permitted bldg archetypes  
 Mediium density 2-3.5 stories,  
 5-10' lot line brl.,  
 build to linesin front  
 40-60 dwelling units per acre  
 no required retail , coner stores ok  
 historic materials,  
 historic window deails  
 sidewalk and planting req.  
 light and ventilation req.  
 back yard terraces, energy

**Transect 3 :**  
**Residential**  
 see permitted bldg archetypes  
 Mediium density 2-3 stories,  
 10'-15' side lot line brl.,  
 build to lines in front  
 20-40 dwelling units per acre  
 no required retail , coner stores ok  
 historic materials,  
 historic window details  
 sidewalk and planting req.  
 light and ventilation req.  
 back yard terraces, energy req.

# STEP THREE : Establish BUILDING TYPE Zone ( T1-T6 )

This density map has yet to be done for Easton



Standard Building features: Large Avenue House

- Clearly delineated window bay configuration
- gabled or pyramid roof configuration w/ dormers
- Entry porches for to all units ( see porch guidelines)
- All Double Hung windows with muntins ( see window page)
- Porches that reflect the window bay pattern
- Chimneys that are functional.
- Decorate cornice at porch entry, and second floor roof cornice
- Build to line ( see setbacks)
- Window trim and shutters recommended / optional
- Painted or natural exterior, no vinyl, but cement siding ok.

**Graphics by Jay Corvan  
Architect**

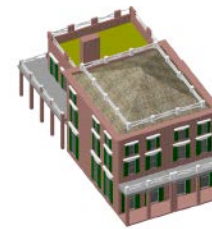

(4) apartment  
row-house



(3-4) unit mansion  
apartment/ SFD

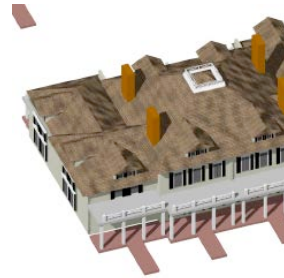

(6-8 ) unit m  
apartment

# Materials and Applications

## PORCH SECTIONS

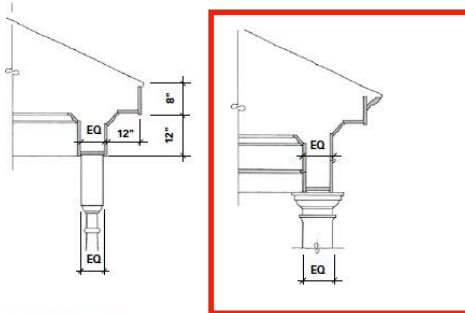

## COLUMN TYPES

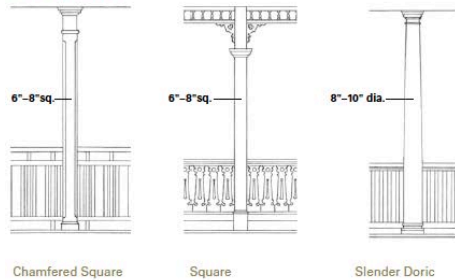

## RAIL DETAILS

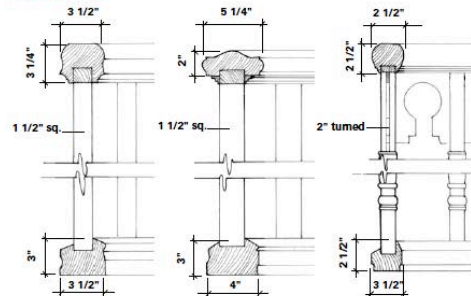

## Roofing

- >> Sawn, laminated asphalt or composition shingles with a slate pattern, or painted metal standing seam or 5-V crimp panels

## Soffits

- >> Smooth-finish composition board, tongue-and-groove wood boards, or fiber-cement panels

## Gutters and Downspouts

- >> Half-round or ogee profile gutters with round or rectangular downspouts in copper, painted, or prefinished metal

## Cladding

- >> Smooth-finish wood or fiber-cement lap siding, 4 to 6 inch exposure
- >> Smooth-finish brick, common bond
- >> Decorative cut wood or fiber-cement shingles in fishscale, diamond, and staggered patterns
- >> Vinyl siding approved by the Vinyl Siding Institute

## Trim

- >> Wood, polyurethane, or composite millwork
- >> Manufacturer's vinyl profiles with integral concealed j-channel; engineered lumber rabbeted or over blocking to conceal the j-channel; exposed j-channel trim is not permitted

## Foundations and Chimneys

- >> Brick veneer, smooth stucco, or cement parging finish

## Windows

- >> Painted wood or composite, or clad wood or vinyl; true divided light or simulated divided light (SDL) sash with traditional exterior muntin profile (3/8 inch wide)

## Doors

- >> Wood, fiberglass or steel with traditional stile-and-rail proportions and raised panel profiles, painted or stained

## Shutters

- >> Wood or composite, sized to match window sash and mounted with hardware to either be or appear to be operable

## Columns

- >> Square box column with chamfered corners in built-up wood, fiberglass or composite material
- >> Turned posts (minimum 6-inch stock) in wood, fiberglass or composite material

## Railings

- >> Milled wood or composite top and bottom rails with square, turned or scroll-cut board balusters

## Porch Ceilings

- >> Plaster, tongue-and-groove wood or composite boards, or beaded-profile plywood

## Front yard Fences

- >> Wood picket or composite material to be rendered indistinguishable from wood, or metal with ornamental posts; low brick walls

## Lighting

- >> Porch pendant, porch fanlight, or wall-mounted lantern



## STEP FOUR: Establish Density Zone ( T1-T6 )

Possible ways to simplify the approval procedure by using typical “village based” details: with certain building types.

Graphics by UDA



How to decide what and where transects are , how to gauge village densities.

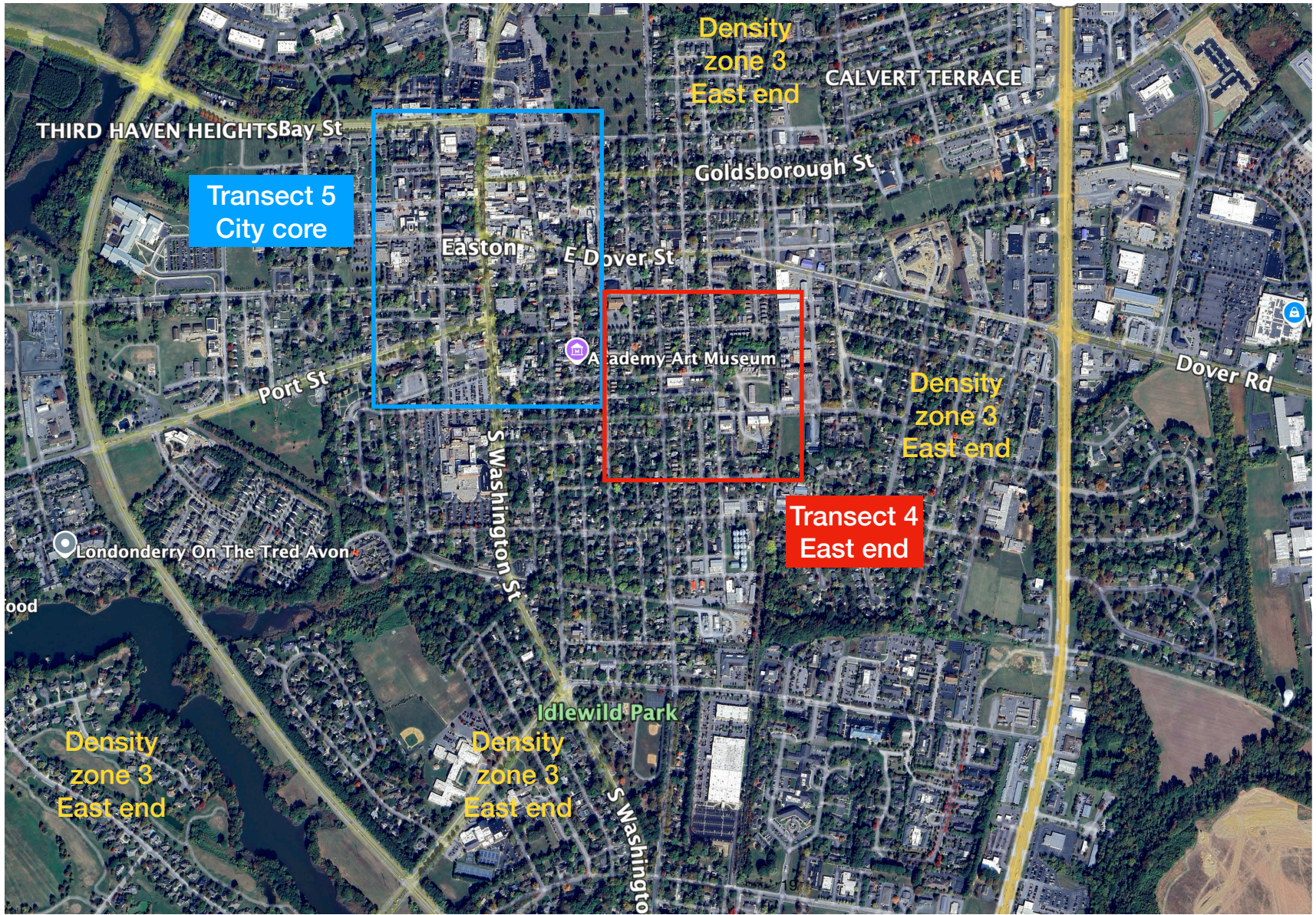

Graphics by Jay  
Corvan Architect



How to decide what and where transects are, and how to gauge village densities.

Lot requirements



## How To Use Traditional Village Planning / Zoning

STEP #2: Building Use Type

ESTABLISH A PLACE IN  
THE CITY : By Density  
zone 1-6

Here depending on location  
types of buildings are  
permitted, and encouraged.

Graphics by UDA

# How To Use Traditional Village Planning / Zoning

## STEP #1

ESTABLISH A PLACE IN THE CITY : By Density zone 1-6  
O This is the Denton Map, Note how certain places in the city a neighborhood can have higher density and different character .

Which Density Zone is the redevelopment property in ?

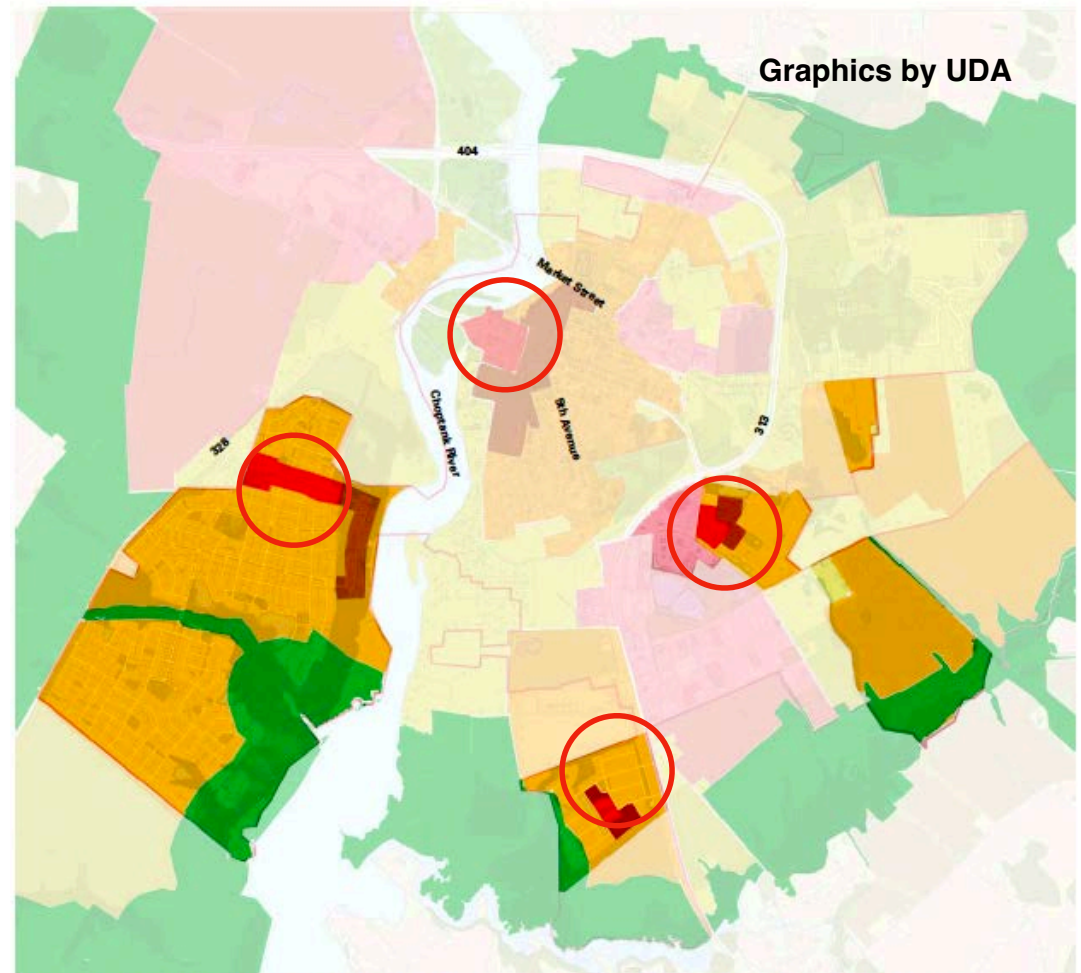

This map of Denton's Transect Zones highlights Planned Neighborhood (PN) projects, generally of a large scale, that will have areas that reflect most if not all of the transect zones within their borders. By using the principles of the Transect and the ideas contained in this Pattern Book, developers can ensure that their projects remain neighborly to adjacent uses both in scale and character.

D-6

D-5b

D-5a

D-4

D-3

Graphics by Jay Corvan  
Architect



**Transect 6 :**

**Mixed use**  
 resid. - commercial  
 see permitted bldg archetypes  
 High density 3-4 stories,  
 zero lot ine , build to lines  
 80 dwelling units per acre  
 required retail on lower floors  
 brick exterior, cornices,  
 historic window deails  
 sidewalk and planting req.  
 light and ventilation req.  
 roof terraces, energy req.

**Transect 5B :**

**50% Mixed use**  
 resid. - commercial  
 see permitted bldg archetypes  
 High density 3-4 stories,  
 zero lot ine , build to lines  
 80 -100 dwelling units per acre  
 possible retail office on lower floors  
 brick exterior, cornices,  
 historic window deails  
 sidewalk and planting req.  
 natural light and ventilation req.  
 roof terraces, energy req.  
 open public space 20% req.

**Transect 5A :**  
**Residential**

see permitted bldg archetypes  
 High density 3-4 stories,  
 zero lot ine , build to lines  
 60- 80 dwelling units per acre  
 possible retail office on lower floors  
 brick exterior, cornices,  
 historic window deails  
 sidewalk and planting req.  
 natural light and ventilation req.  
 roof terraces, energy req.  
 open public space 20% req.

**Transect 4 :**  
**Residential**

see permitted bldg archetypes  
 Mediium density 2-3.5 stories,  
 5-10' lot line brl.,  
 build to linesin front  
 40-60 dwelling units per acre  
 no required retail , coner stores ok  
 historic materials,  
 historic window deails  
 sidewalk and planting req.  
 light and ventilation req.  
 back yard terraces, energy

**Transect 3 :**  
**Residential**

see permitted bldg archetypes  
 Mediium density 2-3 stories,  
 10'-15' side lot line brl.,  
 build to lines in front  
 20-40 dwelling units per acre  
 no required retail , coner stores ok  
 historic materials,  
 historic window details  
 sidewalk and planting req.  
 light and ventilation req.  
 back yard terraces, energy req.

# **East End Design :**

## **Talbot County Health Dept. site**

**An Example of how Planning with new Zoning Standards would work in a medium density community , using the Talbot County Health Department site as an example,..**

**Jay Corvan Architect , 4/25**

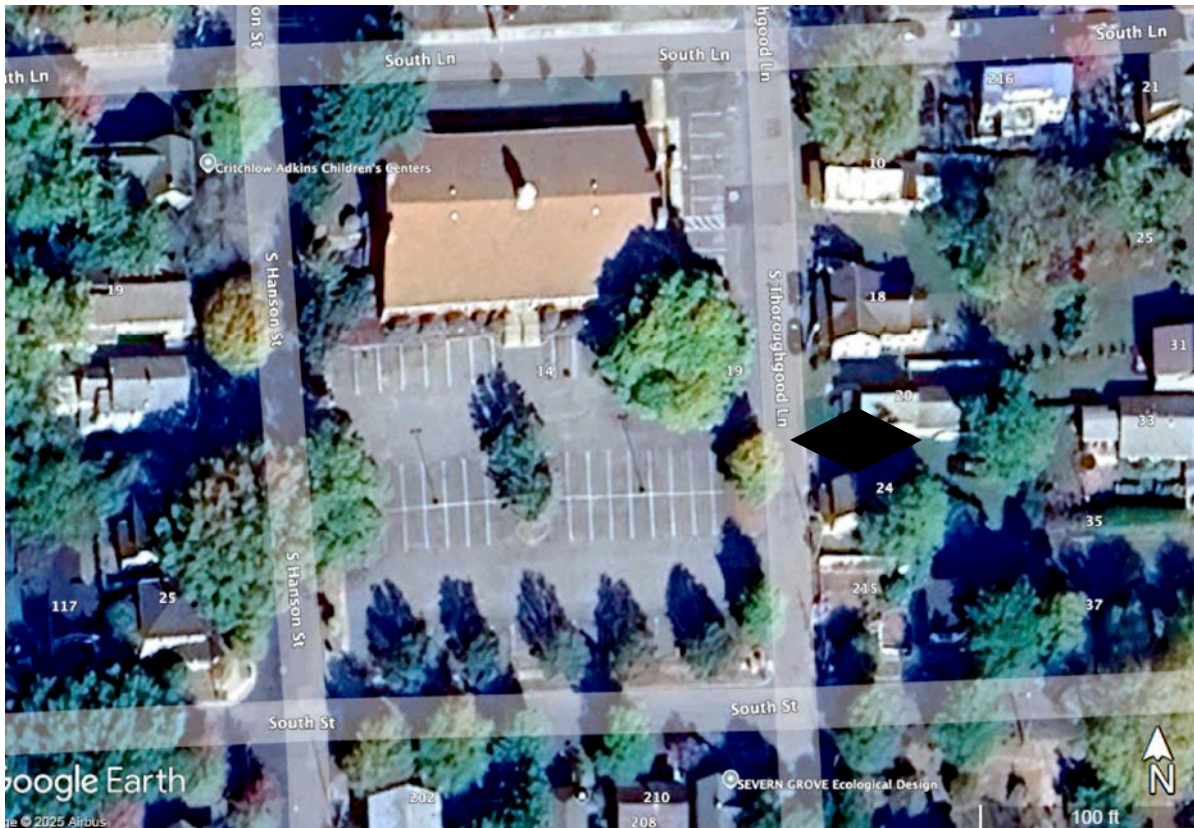

This is a air view ( plan view ) of the Talbot County Health Department site ,

Hanson street , South Street , South Lane, South Thoroughgood Lane

The site area Is almost exactly 1 acre

Graphics by Jay Corvan Architect

Tabot Co  
Health site

What T- # does this site want to be?  
At 40 units per acre its likely a T-4

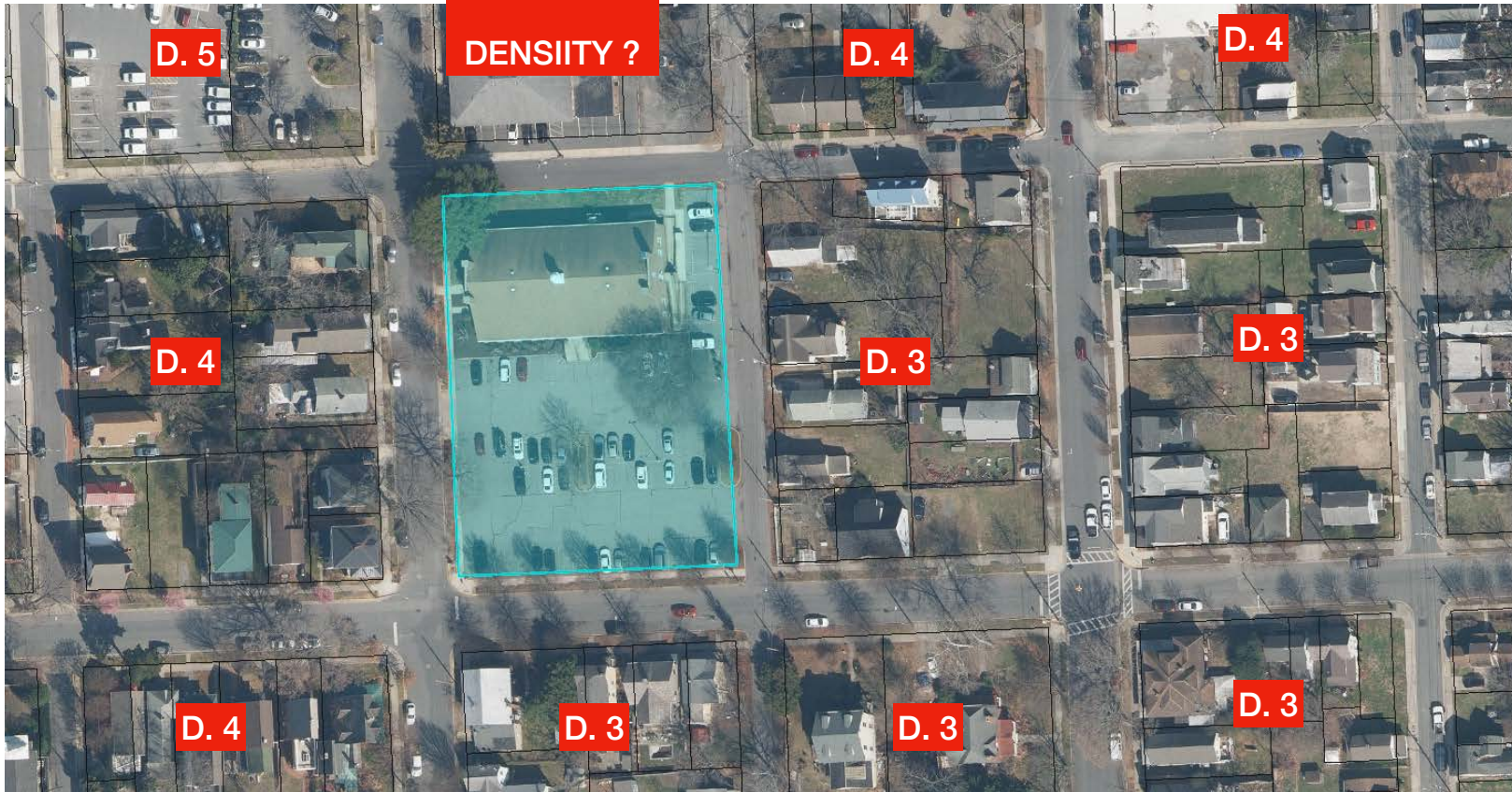

Graphics by Jay Corvan  
Architect



## QUESTIONS:

- . How will parking be accommodated , is that a cost to the developer or the city?
- . Do we have the Utility Infrastructure,
- . What are the Impact fees if we already need housing ,
- . Can the traffic be accommodated
- . Community Impact on common facilities...

many very important things not shown in this presentation , but will be discussed at length



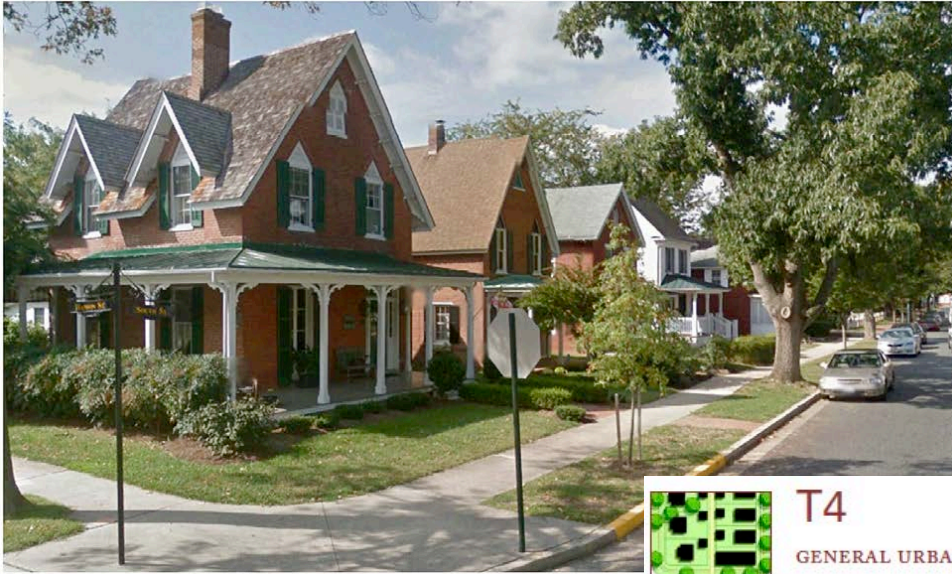

**T4**

GENERAL URBAN ZONE

Varying house types line the streets of the T4 zone. These house types range from large single-family houses to attached types in the form of one large house. The neighborhood street is relatively narrow, and the streetspace is defined by small front yards and gardens with landscape elements. Generally, driveways lead from the street to garages with carriage units above. Corner lots are often serviced from side streets to help maintain the denser neighborhood character.



# TALBOT HEALTH DEPARTMENT SITE

An example



Transect 3 :DENSITY 40 units per acre...

Residential USE  
see premitted bldg archetypes  
Mediium density 2-3 stories,

10'-15' side lot line brl.,  
build to lines in front  
20-40 dwelling units per acre  
no required retail , coner stores ok  
historic materials,  
historic window details  
sidewalk and planting req.  
light and ventilation req.  
back yard terraces, energy req.

## POSSIBLE INFILL SCENARIO: #1 Using Density Zone 3:

Graphics by Jay Corvan  
Architect



Transect 3 :  
Residential  
see permitted bldg archetypes  
Medium density 2-3 stories,  
10'-15' side lot line brl.,  
build to lines in front  
20-40 dwelling units per acre  
no required retail , corner stores ok  
historic materials,  
historic window details  
sidewalk and planting req.  
light and ventilation req.  
back yard terraces, energy req.

## POSSIBLE INFILL SCENARIO: #1 Using Density Zone 3: Rear View

Graphics by Jay Corvan  
Architect



Transect 4 : 20-24 units  
1/2 of the site  
20 percent open space  
Residential / commercial  
see permitted bldg archetypes  
Medium density 2-3.5 stories,  
5-10' lot line brl.,  
build to lines, in front brl.  
follows 40 dwelling units per acre  
no required retail , corner stores ok  
historic materials,  
historic window details  
sidewalk and planting req.  
light and ventilation req.  
back yard terraces, energy req.

## POSSIBLE INFILL SCENARIO: #2 Using Density Zone 4: Front Street View

Graphics by Jay Corvan  
Architect



Transect 4 : 20-24 units  
1/2 of the site  
20 percent open space  
Residential / commercial  
see permitted bldg archetypes  
Medium density 2-3.5 stories,  
5-10' lot line brl.,  
build to lines, in front brl.  
follows 40 dwelling units per acre  
no required retail , corner stores ok  
historic materials,  
historic window details  
sidewalk and planting req.  
light and ventilation req.  
back yard terraces, energy req.

## POSSIBLE INFILL SCENARIO: #2 Using Density Zone 4: Rear Street View

Graphics by Jay Corvan  
Architect



Transect 5A :  
Residential  
see permitted bldg archetypes  
High density 3 - 3.5 stories,  
zero lot line , build to lines  
60- 80 dwelling units per acre  
possible retail office on lower floors  
brick exterior, cornices,  
historic window details  
sidewalk and planting req.  
natural light and ventilation req.  
roof terraces, energy req.  
open public space 20% req.

## POSSIBLE INFILL SCENARIO: #3 Using Density Zone 5: Front Street View

Graphics by Jay Corvan  
Architect

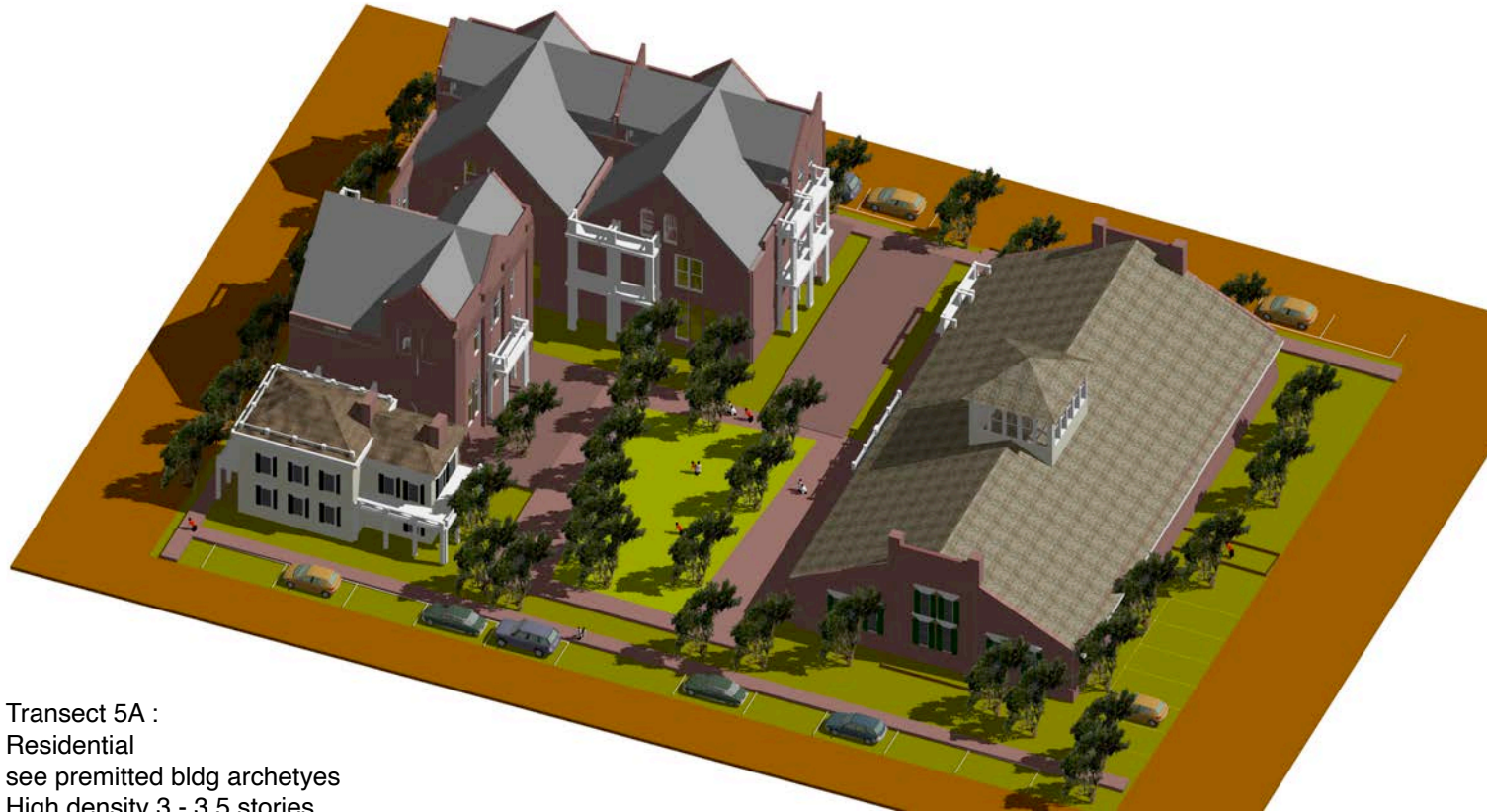

Transect 5A :  
Residential  
see permitted bldg archetypes  
High density 3 - 3.5 stories,  
zero lot line , build to lines  
60- 80 dwelling units per acre  
possible retail office on lower floors  
brick exterior, cornices,  
historic window details  
sidewalk and planting req.  
natural light and ventilation req.  
roof terraces, energy req.  
open public space 20% req.

## POSSIBLE INFILL SCENARIO: #3 Using Density Zone 5: Rear Street View

Graphics by Jay Corvan  
Architect



**POSSIBLE INFILL SCENARIO:  
#4 Using Density Zone 5:  
Overhead View**

Transect 5A :  
Residential  
see premitted bldg archetypes  
High density 3 - 3.5 stories,  
zero lot ine , build to lines  
60- 80 dwelling units per acre  
possible retail office on lower floors  
brick exterior, cornices,  
historic window deails  
sidewalk and planting req.  
natural light and ventilation req.  
roof terraces, energy req.  
open public space 20% req.

Graphics by Jay Corvan  
Architect

## POSSIBLE Residential Building Types for Density : Zone 5 /6

Graphics by Jay Corvan  
Architect



Transect 5A :  
Residential  
see permitted bldg archetypes  
High density 3 - 3.5 stories,  
zero lot line , build to lines  
60- 80 dwelling units per acre  
possible retail office on lower floors  
brick exterior, cornices,  
historic window details  
sidewalk and planting req.  
natural light and ventilation req.  
roof terraces, energy req.  
open public space 20% req.

Building Use Types:

Modeled on existing successful prototypes in village

Here is an example of the

Large avenue house that can be repurposed as an apartment building ( a mansion apartment)



es

### Standard Building features: Large Avenue Houses

- Clearly delineated window bay configuration
- gabled or pyramid roof configuration w/ dormers
- Entry porches for to all units ( see porch guidelines)
- All Double Hung windows with muntins ( see window page)
- Porches that reflect the window bay pattern
- Chimneys that are functional.
- Decorate cornice at porch entry, and second floor roof cornice
- Build to line ( see setbacks)
- Window trim and shutters recommended / optional
- Painted or natural exterior, no vinyl, but cement siding ok.

Graphics by Jay Corvan  
Architect

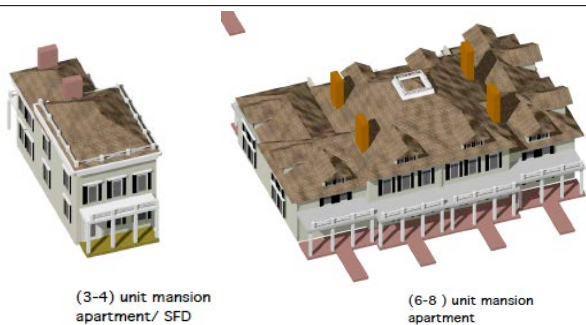

## Building Types: Descriptions in Transects

- . List of Standard building features
- . Standard massing configurations
- . Building heights and area ( range )
- . Roof configurations( range)
- . Types of windows and doors
- . Exterior porch types ( range)
- . Chimney types and placements
- . Landscape req. and buffer yards
- . Lighting and other site criteria

# BUILDING TYPOLOGY : Small Commercial

## Small Avenue Typology

### Transects 4 - 5 , Easton Maryland

SMALL COMMERCIAL : Standard features:

- Brick construction at all public facades ( corner bldgs)
- Double Hung upper windows with muntins ( see window page)
- Entry Porches to protect visitors, display storefront windows ( per window guidelines)
- Decorative brick or metal cornice , arches, bracket details
- Build to line ( see perscribed setbacks)
- Natural Lighting and Ventilation Requirements
- Public sidewalk and Landscape requiements , per site locations



Graphics by Jay Corvan  
Architect

## BUILDING TYPOLOGY : Accessory structures Transects 2-4, Easton Maryland



Standard features:

HEIGHT AND AREA:

1 - 2 story typically wood frame , brick ok.

typically 5- 10' setback on sidelot

Build to line ( see setbacks)

FEATURES:

Roof slope minimum 5/12 , wd/ comp shingle or ss seam metal

2-3 bay window streetfront configuration, all "punched openings)

Double Hung with muntins ( see window page)

Carriage house doors , no overhead doors

Window trim and comp. shutters recommended / optional

Window heights decrease going main to upper floors.

Painted or natural exterior, no vinyl, cement siding ok.

Graphics by Jay Corvan  
Architect



(3-6) garage  
w/ apartments over

End of presentation #1 / for PC

Infill Project:

Route fifty corridor project :

Large Parcel development Project :

Density Zone Mapping Project:

Building Type Project :

Neighborhood character Project :

## Possible Flow Diagram: NEW VILLAGE ZONING:

After Staff meeting with new client / applicant, first drawings are submitted to the staff for compliance . Village Zoning code is code, not a guideline.

- a. Staff reviews the application for compliance
- b. Staff for revisions , cites why it does or does not comply with Village Ordinance.
- c. Applicant submits final design plans to Staff, another check for compliance
- d. If approved to move ahead the applicant submits to the Planning Commission

This will likely mean a much easier approval process with better public satisfaction for the applicant and for the PC from the point that PC has not had to gauge whether community will approve, and redirections may not be necessary over and over again. This should make the PC work much easier and less contentious.







Base layout of development

Franklin Square Denton

Graphics by Jay Corvan Architect

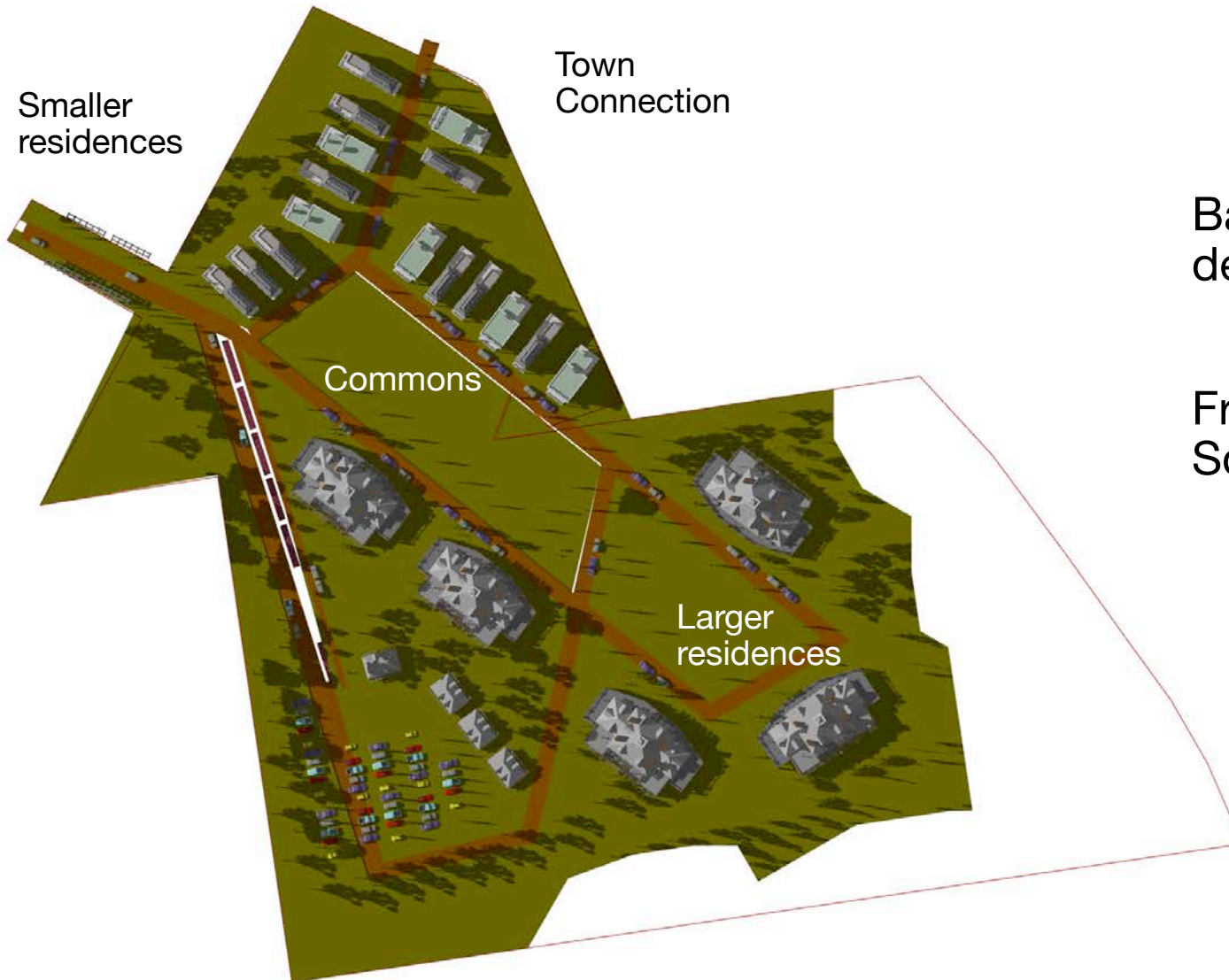

Base layout of development

Franklin Square Denton

Graphics by Jay Corvan Architect



Organization around a  
Common Square to create  
public space exchanged  
for density

Development of  
housing types

Franklin Square  
Denton



Development of housing types as allowed in T4/T5.

Franklin Square Denton



Graphics by Jay Corvan Architect



Just an Example:

Bird's eye of The development using 3D modeling to show how density is built out

Franklin Square  
Denton

Graphics by Jay Corvan  
Architect

TOWN OF



# DENTON

A PATTERN BOOK FOR DENTON NEIGHBORHOODS



URBAN DESIGN ASSOCIATES

**DENTONTOWN COUNCIL**John A. Foster, *Mayor*Conway Gregory, *Vice Mayor*Lester L. Branson, *Council Member*Robert L. Clendaniel, *Council Member*Dennis D. Porter, *Council Member*

*Special thanks to former Council Members:* Carol D. Stockley and J. Bradford Horsey

**DENTON PLANNING COMMISSION**Doris Walls, *Chairperson*Frank Fluharty, *Vice-Chair*

David Gray

Jake Holmes

Valerie Miller

**HISTORIC ARCHITECTURAL REVIEW COMMITTEE**Kathy Mackel, *Chairperson*Sarah Golas, *Vice-Chair*

Irving Bowie Hall, Jr.

Richard S. Peterson

Melissa Jones

**CONSULTANT TEAM**

Urban Design Associates

Redman/Johnston Associates, Ltd.

**CONTRIBUTORS**

Maryland Department of Natural Resources

Sonny Callahan

**ACKNOWLEDGEMENTS**

The Denton Pattern Book would not have been possible without the generous support of the Chesapeake Bay Trust.

**FINANCIAL ASSISTANCE PROVIDED BY:** The Coastal Zone Management Act of 1972, as amended, administered by the Office of Ocean and Coastal Resource Management, National Oceanic and Atmospheric Administration (NOAA). A publication of the Maryland Coastal Zone Management Program, Department of Natural Resources pursuant to NOAA Award No. NA04NOS4190042



# Purpose and Aspirations

The best qualities of historic towns are those that provide connections between the elements most meaningful to both past and future, whether those are connections between people and a sense of community, between places and buildings, or between heritage and growth. The Denton Pattern Book describes the town's unique character and the essential characteristics of Denton's built form that citizens know and cherish. The Pattern Book also presents the public vision for perpetuating those characteristics along with strategies, applicable to both revitalization and new development projects, for achieving that goal.

Denton's citizens participated actively in a public planning process to create the vision embodied in this Pattern Book. What emerged clearly from the process is that citizens want development to be harmonious with the town's historic traditions and future buildings and spaces to reflect the cherished characteristics of the

region's existing buildings and streets. By defining the feel of Denton as a community, in tandem with the mechanics by which the town will evolve, the Pattern Book demonstrates how to create a future for Denton in keeping with its citizens' aspirations.

Because Denton is at an important crossroads in its evolution, the Pattern Book is particularly timely. Like many communities along Maryland's Eastern Shore, Denton is experiencing intense growth pressure, both infill and on many acres of rural land at the town's edges. The Pattern Book illustrates how to properly plan and design for that growth. The qualitative design measures contained in the Pattern Book augment the requirements defined in zoning and other development-related requirements. Compliance with the Pattern Book is strictly voluntary for detached single family homes (see ordinance for applicability).

## Table of Contents

**A INTRODUCTION**

Public Process 1

Overview 1

How to Use the Denton Pattern Book 2

**B ESSENTIAL QUALITIES OF DENTON TODAY**

Overview 4

Building Green at the Community Scale 5

The Transect of Denton 6

Community Character 8

Town of Denton: Existing Development and Proposals 10

Courthouse Square and Downtown Market Street 12

In-Town Neighborhoods 14

Fifth Avenue 16

South Second Street 18

Edge of Town Neighborhoods 20

Civic Spaces 22

**C STRATEGIES FOR NEW DEVELOPMENT**

Overview 24

Urban Patterns for Infill 26

Urban Infill Kit of Parts 28

Urban Patterns for New Development 30

New Development Kit of Parts 32

**D BUILDING TYPES**

Overview 34

Building Types and the Transect 35

Civic Buildings 36

New Type 36

Large-Scale Commercial Buildings 37

Mixed-Use and Live/Work Buildings 37

Townhouses 38

Attached Housing 38

Single-Family Houses 39

Carriage Houses 39

**E ARCHITECTURAL STYLES**

Overview 40

Denton Victorian 42

Denton Colonial Revival 50

Denton Craftsman 58

Materials and Methods (For All Styles) 66

Architectural Resources 67

**F GREEN BUILDING GUIDELINES**

Overview 68

Strategies 69

**G HOME OWNER'S GUIDE**

Overview 72

Building the Denton House 73

Renovations 74

Additions 76

Transformations 78

Garages, Driveways, and Yards 80

**H ENVIRONMENTALLY RESPONSIBLE LANDSCAPE DESIGN**

Overview 82

Strategies and Techniques 83

Plant Palette 86

Landscape Resources 88

**APPENDIX**

Glossary of Terms 90

References 92

A Pattern Book History 93

## Public Process

A number of well-attended meetings were held throughout the development and completion of the Denton Pattern Book. The idea of connections to geography, place, as well as local culture, architecture and building traditions was voiced by nearly every resident who participated in the process. The desire to retain Denton's rich architectural heritage in both infill and new development was a common theme. This document responds to those desires by defining the essential positive qualities which Denton's citizens want to maintain and build upon well into the future.

Residents were asked to voice their opinions on the existing strengths of Denton. Those most frequently cited were a sense of community and history; long-term, dedicated residents; the form of the downtown and its neighborhoods with their front porch life; the town's presence as Caroline County's seat; Courthouse Square and other community institutions, such as a strong town government; Denton's geographic location and natural

setting along the Choptank River; its parks, such as Martinak State Park; and the events, gatherings, and connections between people and local history and culture.

Public input also identified these weaknesses: poorly-maintained streets and a lack of pedestrian connectivity, particularly between the existing town and new development; a lack of character, quality, and sense of place in recent development; a lack of pride in ownership, absentee landlords, and inadequate upkeep of buildings; a lack of shopping, businesses, and restaurants in the downtown; and a lack of a strategy for managed, positive growth.

In addition to identifying existing strengths and weaknesses, residents were asked about the most important qualities to preserve. They cited individuality and character in architectural and town design; village character with natural edges, a defined center, and connected, walkable neighborhoods; connections to the Choptank River, nature, and agricultural lands; small-town charm; and a sense of place as a destination.



## Overview

The Pattern Book begins with this Introduction, in which the collective aspirations of the town are presented as a foundation on which the Pattern Book was developed. Following that is a brief explanation of how to use the Pattern Book effectively.

The Essential Qualities of Denton Today are described in Section B. The section introduces the concept of the Transect as a tool for guiding appropriate development. Section B also presents information about Denton's Existing Development and identifies five types of neighborhood patterns useful to both developers and home owners in the conceptual design of projects.

Section C presents urban patterns, strategies, and a kit of parts for infill and new development projects to assist developers in understanding all of the parts required to create desirable, whole places.

Section D focuses on Building Types appropriate for Denton – those which have historic precedents in the region which respond well to marketplace needs and desires.

The Architectural Styles section describes three styles prevalent in Denton from its architectural history: Victorian, Colonial Revival, and Craftsman. These styles are detailed in terms of site and building characteristics that will help developers and home owners to plan,

design, and construct buildings that retain stylistic integrity using today's building materials and techniques. The section includes Architectural Resources and a discussion of Materials and Methods.

The next section, Green Building Guidelines, presents strategies and techniques for building and maintaining healthier, more energy efficient and environmentally-friendly buildings and houses. A companion to this, the Environmentally Responsible Landscape Design section provides strategies and techniques for stewardship of our natural environment. The strategies contained in both of these sections directly relate to the Town's green building objectives which can be found on the Town's website. A Plant Palette as well as Landscape Resources are included at the end of the Landscape Design section.

The Home Owner's Guide provides guidance for individuals contemplating renovations, additions, or transformations of their houses. This section provides ideas for designing and implementing individual projects so the results may be in character with the house type and neighborhood and contribute to long-term value of the property.

At the back of the book you'll find a Glossary of terms used in the Pattern Book and Reference articles.



# How to Use the Denton Pattern Book

The following steps offer direction on how to use the Denton Pattern Book. This document offers strategies to both existing residents of Denton who are looking to change aspects of their house, as well as to private developers and builders who aspire to build communities of lasting value in Denton. Denton is an historic town that is growing. This Pattern Book describes ways to create places that connect with its best intrinsic qualities.

## Step 1

**IDENTIFY YOUR LOCATION:** Refer to Section B to identify the Transect Zone that pertains to your site, project or house. By using the Transect, you will be better able to understand the scale and character of the different areas that make up Denton, as well as the appropriate way that new communities should be developed. The Transect also evaluates the type and scale of existing places in town so that you understand the characteristics of your specific environment. The illustrations provide guidance in helping you identify the Transect Zone(s) that relate to your area, as well as depict the general feel and rules for development.



## Step 2

**IDENTIFY YOUR NEIGHBORHOOD:** Different parts of Denton's urban fabric have developed in different ways. You'll find a description of five neighborhood patterns beginning on page 12 in Section B. The description of each of these types provides an overview of its unique, defining qualities. By analyzing both the essential characteristics of the various parts of town, one can understand the defining elements of the sub-area in which they live or for which their project is proposed.

If you already own a house, find the neighborhood area where you live. Read through the essential elements of that neighborhood in order to learn more about the building and landscape characteristics that define your locale. The characteristics described, such as the typical front yard depth, streetscape character, house spacing, and landscape treatments, are meant for your use in fitting into and strengthening the neighborhood.



If you are developing a new community, consider your adjacency to the existing town and see to it that the new development relates to that existing character. If you are developing within the existing core, figure out the classified sub-area your parcel is located in and coordinate development with those guidelines.

## Step 3

**IDENTIFY YOUR BUILDING TYPE AND STYLE:** A traditional town such as Denton is composed of a variety of uses housed in building types of varying scales. The choice of an appropriate building type is relevant whether you own a house, want to do infill development, or are building a new neighborhood or community. Find the Building Types appropriate for your Transect Zone and scale of development in the matrices on page 35.

Beyond mere building type, Denton has an existing architectural character by which it defines itself. There are three main architectural styles in town: Victorian, Colonial Revival, and Craftsman. These styles should be studied and used for both infill and new development.

## Step 4

**FOR RENOVATIONS OF EXISTING HOUSING:** Throughout towns developed in the nineteenth century, such as Denton, there is often a desire to expand houses to increase living space, to better fit one's house into an historic style and add value, or to bring one's property into a style family, better tied into the architectural traditions of the town. Investment in existing housing stock is encouraged as a way to develop in a cohesive, sustainable manner.

For information on the appropriate means of modifying your house to add space or enhance its style, refer to the Renovations, Additions, and Transformations pages in Section G, the Home Owner's Guide. Green building guidelines are provided as strategies for energy efficiency (in Section F) and environmentally responsible landscape treatments (in Section H).

## Step 5

**FOR NEW CONSTRUCTION:** If you are planning on constructing a new house, refer to the Building a Denton House spread in Section G, the Home Owner's Guide. This series of diagrams outlines the step-by-step process of composing a house with its individual kit of parts and pieces.



For ways to place your house on a lot, refer to the typical lot diagrams shown for each neighborhood in Section B (pages 12 through 21) or the general dimensions appropriate for new construction by building type (pages 37 through 39). The diagrams describe the typical zones of a house lot, such as front yard, front facade, side yard, and

private zone, all of which vary depending on the location of the lot within town. Placement by building type is also handled for all new development. Environmental design options that can be used to improve the site design are also included.

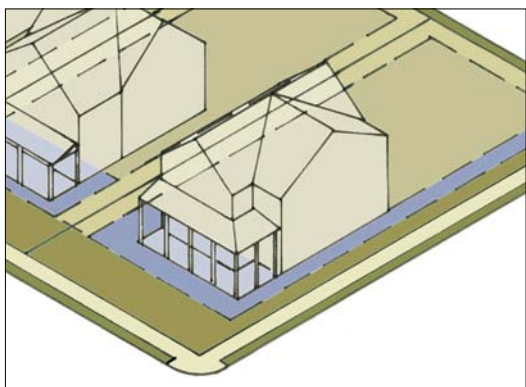

### Step 6

**REVIEW THE ARCHITECTURAL STYLE SECTIONS:** Three architectural styles are documented for Denton: Victorian, Colonial Revival, and Craftsman. While other vocabularies are scattered throughout town, these three predominant styles largely create its character.

#### HISTORY AND CHARACTER

Each style begins with a brief description of the style and its history. Photos of relevant examples found in Denton are shown along with the essential qualities of each style. Use these materials to find your particular style family.

#### MASSING AND COMPOSITION

This page describes the basic massing types or shapes of houses found in Denton for each architectural style. Each massing type is shown as a three-dimensional image with a corresponding elevation diagram of the main body of the house. Identify the diagram that most closely resembles your house.

#### WINDOWS AND DOORS

Windows and doors relate to the style of a house. Typical compositions are illustrated for each style. Often, missing windows or awkward compositions are the primary elements that stand in the way of identifying your house style. In terms of details, typical proportions, trim, and special elements are

illustrated to outline a menu of choices when replacing these elements.

#### PORCHES AND CHIMNEYS

Porches are essential elements of the character of many Denton neighborhoods. They provide comfortable outdoor space where neighbors spend time and create a pleasant community life. The location and design details of porches are covered on this page. The massing of the front porch is distinct within a particular style. Good porch proportions make for a well-scaled house facade.

#### MATERIALS AND APPLICATIONS

This page includes a list of preferred materials and their application. Also included are a few facade possibilities composed using elements described on the previous pages to illustrate the end result that can be achieved if one follows the guidelines in the Pattern Book.

### Step 7

**REVIEW THE ENVIRONMENTALLY RESPONSIBLE LANDSCAPE DESIGN STRATEGIES:** These landscape strategies will provide you with specific techniques for responsible environmental stewardship of your property and its effect on the natural environment of our area.



### Step 8

**REVIEW THE MATERIAL MANUFACTURERS AND RESOURCES LISTS:** A list of material manufacturers for items such as doors, windows, columns, and moldings is located at the end of Section E: Architectural Styles. This list is meant to serve as a resource when searching for the appropriate building supplies for work on your house, or for use by developers and builders in finding material suppliers for large infill or new development efforts.



## SECTION B

# ESSENTIAL QUALITIES OF DENTON TODAY

Denton has distinct community and neighborhood patterns that reflect the historic development of the town. Understanding these patterns aids in identifying the way new and infill development should relate to what already exists as well as the role that individual buildings can play in creating new places in keeping with local and regional traditions. This section begins with a brief description of sustainability as a key principle for historic preservation, adaptive reuse, infill development, and new mixed-income development.

Denton, an historic Eastern Shore town with a mixed-use core and neighborhoods connected to that core by an interconnected network of streets, has achieved its current state of development using development patterns and principles that provided sustainability somewhat inherently. To ensure long-term sustainability of the town and its surrounds, we must consciously respect and support these successful patterns and principles as precedents and models for all future development.

The Transect, a method for guiding development that is coherent, human-scale, pedestrian-friendly, and in harmony with the natural environment, is one of the best large-scale tools for traditional town planning and the development of sustainable communities. This section describes the Transect as a concept then applies it to Denton, identifying development zones based on the scale, density and types of development appropriate for each Transect zone from the most natural zone to the urban core.

The section continues with a map of the existing development and proposals in and around Denton. Because Denton faces pressure to grow within the existing fabric of the town, largely within the I-404 loop, and without, across the Choptank River and beyond, it is important for developers to understand and emulate the best qualities of the five sub-areas of the town: Courthouse Square and Downtown Market Street, the In-Town Neighborhoods, Fifth Avenue, South Second Street, and the Edge of Town Neighborhoods.

# Building Green at the Community Scale

The town of Denton has historically and is continuing to pursue a community growth pattern intrinsically related to sustainable development. Historically a population center for the region, Denton continues to fulfill this role in the context of County and State growth management strategies. With its multi-use center and associated residential neighborhoods, Denton adheres to the first principle for building green communities: to build within existing areas. To continue its place as a locus of planned growth into the foreseeable future, Denton has identified areas appropriate for development within the historic town and its environs as well as the place-making principles that underlie its current character, namely that new development be compact, mixed-use, pedestrian-friendly, and that the activities of daily life be accomplished with limited use of a car.

## Historic Preservation/Adaptive Reuse

The National Trust for Historic Preservation estimates that the energy equivalent of one gallon of gasoline is wasted for every eight bricks destroyed and replaced. In addition, construction and demolition debris accounts for 24 percent of America's landfill volume.

Reusing and rehabilitating damaged or outdated structures is, by definition, a green building practice which saves more resources compared to what is required for new construction. Through building rehabilitation, society retains the initial energy and resources that were

required to make materials such as bricks, mortar, steel, or timber and also establishes a sense of historical and community continuity. Historic buildings are an important link to tradition and offer important educational opportunities. Denton has implemented policies and regulations to encourage and facilitate infill and redevelopment and preserve significant historic structures.

## Location and Use of Existing Infrastructure

Another important factor in building and repairing healthy communities is the choice of location. Wherever possible, projects should be located on infill sites with access to existing roads, water, sewer, and other infrastructure. Locating projects in this manner offers the greatest savings, helps conserve land, prevents the spread of stormwater runoff to new watersheds, and reduces travel distances and pollution from vehicular exhaust. When developing in planned growth areas, provision must be made for adequate public facilities.

Sustainable development practices, involving infill and redevelopment or 'greenfield' development, should begin with proper site selection which avoids development of inappropriate areas and damage to fragile and/or scarce environmental resources. Development should not be located on wetlands, steep slopes, parkland, or other ecologically-sensitive areas. Development should not be located on prime farm land in the County, but instead should be directed to planned growth areas within existing communities where adequate public facilities and services can be provided in the most cost-efficient manner.

## Diverse, Mixed-Income Communities

Building diverse, mixed-income communities provides an opportunity for people of all ages, races, and income groups to thrive. Neighborhoods should provide a diversity of unit types to accommodate different needs and uses. The integration of affordable and market-rate housing into a medium-density, mixed-income, mixed-use environment helps create long-lasting, healthy communities.

In order to reinforce and enhance the Town's commitment to environmental design and preservation, a series of sustainable growth objectives have been developed. A summary of these objectives are included at right. Further details regarding these techniques and practices are available in Section H: Environmentally Responsible Landscape Design in this Pattern Book and from the Town Office.

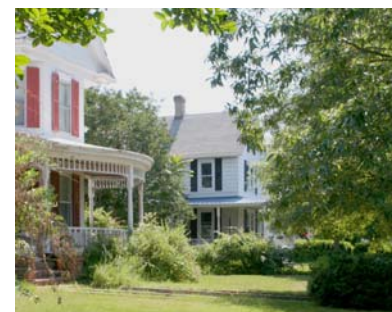

### Green Building Objectives

- >> Land Stewardship
  - Site selection
  - Infrastructure
  - Site stewardship
- >> Community and Neighborhood Character
  - Neighborhood layout
  - Compact development
  - Community resources
  - Home owner education
- >> Environmental Design
  - Landscape and shading
  - Water management, reuse, and irrigation
  - Pest control
- >> Green Building Design
  - House size
  - Construction techniques
  - Indoor environment
  - Appliances
  - Waste management

# The Transect of Denton

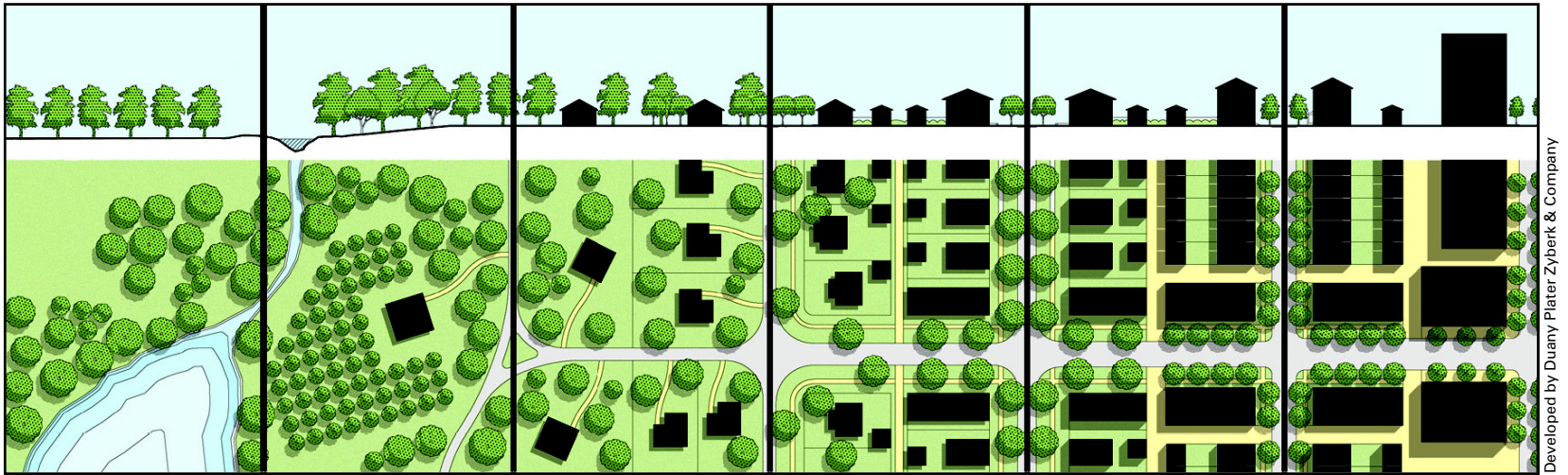

## T1

NATURAL ZONE

## T2

RURAL ZONE

## T3

SUB-URBAN  
ZONE

## T4

GENERAL URBAN  
ZONE

## T5

URBAN CENTER  
ZONE

## T6

URBAN CORE  
ZONE

Developed by Duany Plater Zyberk & Company, the Transect is a tool which defines the hierarchy of development by the scale and location of different settlement types. As the illustration above shows, the Transect includes six zones which range from the most natural undeveloped areas, to rural landscapes, to small hamlets and villages, then larger towns, administrative centers, up to larger urban centers. The Transect is applicable to any place where community visions include the desire to build appropriate and fitting compact, mixed-use development as a way to reduce sprawl and uncoordinated development. Within each Transect zone (T-Zone), all development should be consistent with the scale of development for that zone within the existing town.

Denton fits into Zones T3 through T6. While these zones do not always align linearly, following strict numerical order, from the outer edges of the town into its core, the zones do describe the general scale of different areas of the town's development. The mixed-use center of Market Street near Courthouse Square, the most dense area of Denton, is T6, the urban core zone. The urban neighborhoods closest to Denton's downtown are T5, the urban center zone. The less dense neighborhoods (such as the Fifth Avenue area) are T4, the general urban zone. This area and its adjacent blocks tend to have greater setbacks and distances between houses. Portions of the T4 through T6 zones in Denton will be transformed into new neighborhoods, either as a result of large-scale, planned communities or infill and redevelopment projects, all of which will use the Pattern Book to iden-

tify the appropriate Transect Zone for the proposed development. The sub-urban (T3) and rural (T2) zones of Denton include areas that are planned to remain as 'greenbelt' and natural resource protection areas. The planned greenbelt, which will reinforce the Town's urban growth boundary, will be located along the outer perimeter of Denton's growth areas and will consist of properties the Town would like to see remain essentially undeveloped: forest, open space, agricultural land, and very low density rural residential development.

The Transect map of Denton (shown below) defines the town's Transect zones.

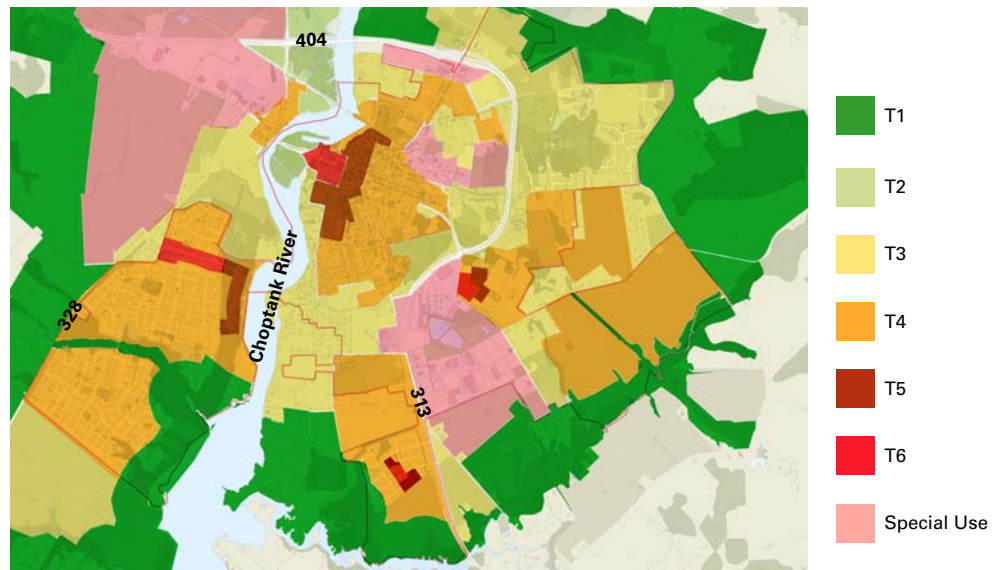

This map of Denton's Transect Zones reflects both existing and planned land use characteristics.

ESSENTIAL QUALITIES OF DENTON TODAY

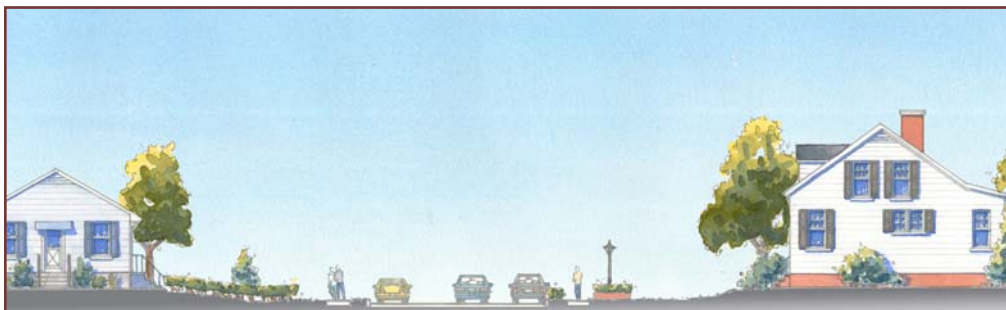

**T3** SUB-URBAN ZONE



**T4** GENERAL URBAN ZONE



**T5** URBAN CENTER ZONE



**T6** URBAN CORE ZONE



# Community Character

Denton's four Transect zones can be illustrated in general ways which apply to both infill and new development. The illustrations on these facing pages depict four different scales of streets and public space, demonstrating how the elements in the Pattern Book can be applied to create appropriate design for each of the Transect zones present in the town



## T3

SUB-URBAN ZONE

A neighborhood street in the T3 zone includes small-to-medium-sized houses on larger lots set back from a more rural, informal street. A wide, planted verge separates the street from the sidewalk. Parking is handled in garages set back behind the facade line of the houses, but serviced from narrow, informal driveways leading from the street.



## T4

GENERAL URBAN ZONE

Varying house types line the streets of the T4 zone. These house types range from large single-family houses to attached types in the form of one large house. The neighborhood street is relatively narrow, and the streetspace is defined by small front yards and gardens with landscape elements. Generally, driveways lead from the street to garages with carriage units above. Corner lots are often serviced from side streets to help maintain the denser neighborhood character.



While these illustrations are idealized images, they do present the essential qualities of different public spaces and neighborhoods in Denton and its environs, as captured in photographic analysis of the existing town and as described by residents during the planning process.



## T5

### URBAN CENTER ZONE

In the T5 zone, houses have very shallow front yards and a minimal planted verge. Houses may have attached units, as in the T4 zone, but in more urban building types. Streets are of a slightly more formal scale. The neighborhoods are much more dense in character, a condition made possible by the presence of alleyways to service houses from the rear. Front porches dominate the residential landscape.



## T6

### URBAN CORE ZONE

Streets in the T6 zone, are larger in scale and accommodate on-street parking to service the mix of uses along their length. These streets support many building types and have the densest associated housing, such as live/work units and residential uses above retail stores. Short-term parking is on-street. Other parking is provided in concealed areas mid-block in order to maintain a consistent street wall. Sidewalks are wide, paved areas that support greater foot traffic and outdoor uses.



# Town of Denton: Existing Development and Proposals





### Introduction

Denton is a tapestry of varying environments, each with its place in the creation of the overall community. It is also a relatively compact community with many new development opportunities on the horizon. The map of existing conditions shown here enables the community to see itself holistically and understand its geographical proximities and boundaries. By applying the analysis of Denton's existing development patterns shown in this map in combination with the information about Denton's five distinct sub-areas, the town can continue to organize future development in the sustainable and responsible manner it is currently pursuing.

### History and Culture

The towns and villages of the Eastern Shore and Caroline County are laid out along the historic trade routes of the area. Denton is the county seat. It was settled along the Choptank River at an area once named Pig's Point, part of a tract of land called Mount Andrew. Urbanization occurred in Denton during two main periods of prosperity, first during the Grain Boom from 1790 to 1819. Almost all building at that time was frame construction and most was destroyed in a fire in 1865.

In 1890, a second boom, the Canning Boom began. Most of the surviving historic architecture in Denton – all late Victorian interpretations – was built during that era by local builders using pattern catalogs. As trade shifted from the river to the railroads, Denton lost its identity as a river city and turned increasingly inland in focus as the downtown core was established on the high ground overlooking the Choptank River.

Beginning with a depression in 1919, little construction occurred in Denton until after World War II. In the 1960s, a flurry of commercial and public rebuilding took place, primarily in the Colonial Revival style, and many of the existing historical buildings in Denton were covered with Colonial Revival facades. But, from the 1970s to the 1990s, little growth occurred in Denton. What growth did take place was outlying with little or no reference to the rich history and architectural styles of Denton or its community and neighborhood patterns.

### Neighborhood Patterns

The historic development of Denton has given rise to a pattern of neighborhoods, each with their own distinct character. For example, the In-Town neighborhoods, meaning the residential development around the core of Market Street where houses are close together and sidewalks are relatively formal, differ in character from the streets that follow the Choptank River south along Second Street, where houses are spread farther apart and the landscape remains lush and rural. These distinctions are among those that provide Denton with its rich variety of places.

Denton's neighborhood patterns are important for two reasons. First, they allow home owners or potential home buyers to understand the place in which they are buying, what is important about the neighborhood, and how to make future investments in their home appropriate for the character of the neighborhood in which it is located. Also, these neighborhood patterns allow the developers of new, adjacent areas within the town to understand the variety of neighborhood types in the existing town, and to pattern their developments after these building traditions so that future parts of Denton relate to its character, history, and sense of place. You'll find more information about Denton's five primary neighborhood patterns on the remaining pages of this section.

# Courthouse Square and Downtown Market Street (T6)

## Essential Elements

- >> Grid of streets with on-street parking for visitors
- >> A main, public green within Courthouse Square
- >> Wide sidewalks along Market Street and sizable, formal sidewalks elsewhere
- >> Granite curbs, street lights, banners, and other forms of downtown streetscape elements
- >> Mature trees, especially along the west, north, and east sides of the Square
- >> Large houses, many converted to offices, businesses, and museums
- >> Houses in traditional architectural styles (high-style examples)
- >> Very large lots with large buildings either attached or spaced closely together
- >> All buildings, whether shopfronts or offices in houses, relate to the street with awnings and large porches
- >> Shallow, well-landscaped front yards and gracious sidewalks along Market Street

Constructed when the town of Denton was founded, Courthouse Square and Downtown Market Street provide the town with its sense of place. The seat of Caroline County, Denton's Courthouse Square is home to a variety of public buildings and uses that serve the county's populace, many in the stately houses that surround Courthouse Square. Downtown Market Street is Denton's mixed-use core and its variety of uses – shopping, dining, banking – attract people to this part of town. Together, the two areas define the heart of the existing town. Not necessarily a neighborhood in the traditional sense (as the area is predominantly institutional and commercial), residences above the shopfronts are an historic and encouraged feature in the downtown.

## Streets

Market Street as it rises from the crossing of the Choptank River provides a picturesque sense of arrival into Denton. Downtown Market Street supports its mix of uses with an appropriate cross-section, usually 34 to 46 feet in width, with parallel, on-street parking along its sides, and head-in parking along Courthouse Square itself. Large, old trees shade the streets in this area, and all converge and wrap around the Caroline County Courthouse, a venerable structure in the heart of Denton.

## Curbs

Curbs are formal, from 6 to 8 inches tall, and may be constructed of granite or concrete.

## Verges and Street Trees

Verges, or tree lawns, are not typical, although trees are located in 3- to 5-foot square grates in the downtown. Street trees are generally spaced 25 to 30 feet on-center and are normally located along the edge of the street.

## Sidewalks

Sidewalks are generally brick along Market Street or, less frequently, concrete. The formality of the brick reinforces the sense of a town core. Sidewalks are relatively gracious at 8 to 23 feet in width. Along the non-commercial uses, a 4-foot sidewalk is typical.

## Lighting

Street lamps are short and of the decorative variety, in scale with the size of downtown Market Street. Street lamps are metal, and occur every 20 to 25 feet. Downtown street lamps support hanging baskets of flowers and banners celebrating downtown Denton.

## Planting

Denton's downtown streets are relatively green due not only to the mature trees that line the street, but also to the hanging baskets and other planters spread throughout the area. Foundation planting is also present in front of the non-commercial structures that ring Courthouse Square.





THIRD STREET

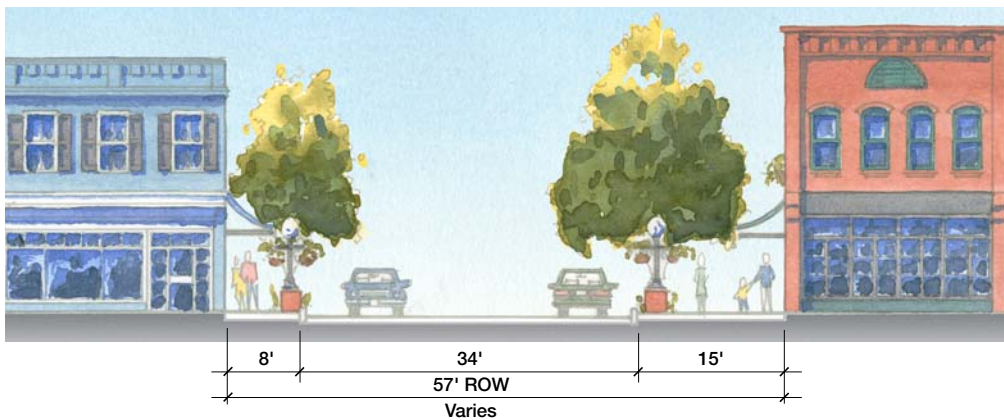

MARKET STREET AT COURTHOUSE SQUARE

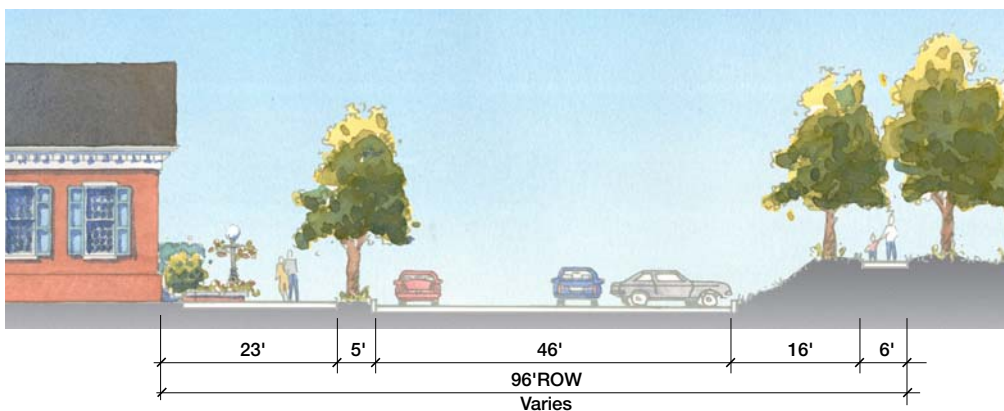

## In-Town Neighborhoods (T5)

### Essential Elements

- >> Consistent network of concrete streets
- >> Flagstone or concrete or brick sidewalks
- >> Concrete curbs
- >> Most houses served by alleys, informal parking areas, or sparing informal driveways
- >> Mature street trees, either in verges or front yards, oriented to the streets
- >> Landscaped front and side yards, with walls, fences, and hedges
- >> Houses in traditional architectural styles, with wider side yards at corners
- >> Moderately-sized front yards



Denton's most urban neighborhoods developed immediately adjacent to the town's mixed-use core. Though differing in their states of repair, loosely, the area between Third Street and Fifth Avenue, High Street and Franklin Street, and extending for a distance along Market Street, comprise Denton's first neighborhoods. Lots are spaced more closely and these areas represent the most urban living in Denton. These neighborhoods, which developed quickly during the booms that built the town, exemplify the Victorian style in both its ornate and simple forms.

### Lot Sizes

Most lots are between 45 to 55 feet wide and about 100 to 120 feet deep. Corner lots are typically ten feet wider than in-line lots. These houses often feature wrapping porches and bay windows that address the street.

### Front Yard Setback

The main bodies of the houses are set back 15 to 35 feet from the front property line. Porches typically extend 8 to 10 feet into the front yard.

### Side Yard Setback

Side yard setbacks total no less than 5 feet to the property line. Slip driveways sometimes occur in the side yards, although most houses have on-street parking and/or are alley-loaded.

### Garages and Ancillary Structures

Garages, if present, are located at the rear of the lot, typically serviced by an alley. Some yards feature other ancillary structures such as sheds. Driveways only occur on corner lots, if at all. Garages are infrequent and no carriage houses are present.

### Streets

Typically, the street rights-of-way range from 36 to 40 feet. The paving, or cartway, is usually 23 to 27 feet

wide in an urban, tight condition with two-way movement and parallel, on-street parking on both sides. Often known as 'yield streets,' these narrow cartways force cars to slow down to pass each other. A few streets have parking on only one side with two-way movement.

### Verges and Street Trees

Verges or tree lawns range from 2 to 3 feet in width. Street trees are generally spaced 25 to 30 feet on-center, located either in the verge or the front yard along the sidewalk.

### Sidewalks

Sidewalks in these neighborhoods are concrete, although Market Street – the most formal street in the area – features brick sidewalks in many places. Sidewalks are generally 4 to 5 feet wide.

### Lighting

Lighting in these areas is typically handled with overhead lights, or 'cobra heads' (undesirable), high above the sidewalks, on power poles.

### Fencing and Garden Walls

Fences and walls provide delineation between public and private space and are typically located on corner lots and as privacy measures to separate the dense backyards. Wrought-iron fences and decorative brick walls are sometimes present. Gardens are often fenced with white pickets, and are related to the style and character of the individual house. The use of chain link fence, and fencing taller than four feet is discouraged.

### Planting

Foundation planting is the most minimal planting present in this area. Shrubbery, hedges, and small flowering trees are found in the yards in relatively informal patterns. Some large trees are also present in backyards.





An in-town house

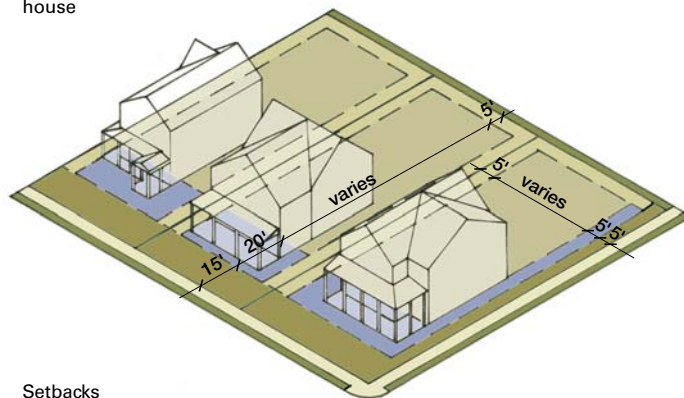

Setbacks

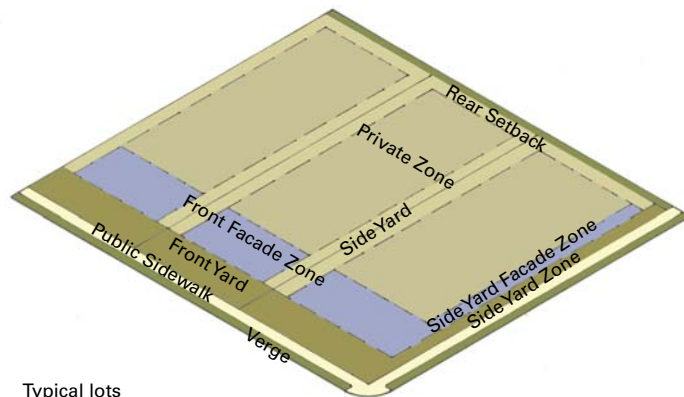

Typical lots

LINCOLN STREET

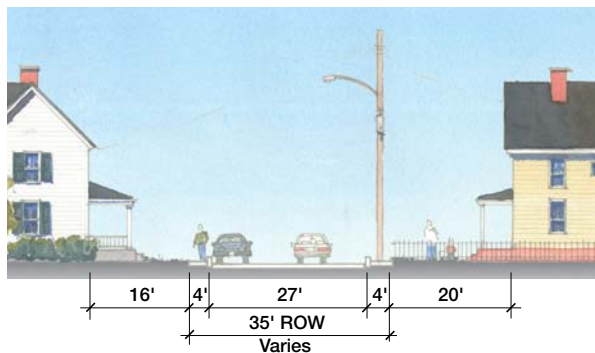

MARKET STREET

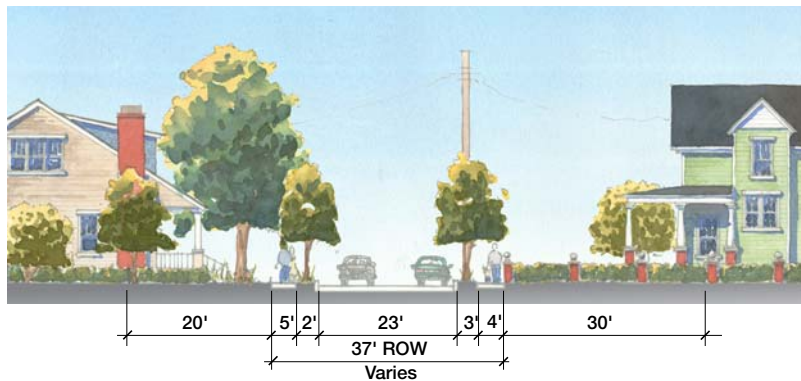

## Fifth Avenue (T4)

### Essential Elements

- >> Streets splay out from the grid of the urban In-Town Neighborhoods
- >> Wide concrete sidewalks
- >> Granite curbs and historic street lights
- >> Mature street trees in verges as well as auxiliary planting in verges
- >> Some houses maintain a step up into the front yard from the sidewalk
- >> Large, high-style houses in traditional architectural styles
- >> Wide lots with gracious setbacks to large, ornate front porches
- >> Well-planted front yards that relate to the style of the house



Fifth Avenue boasts Denton's most stately houses, the edge-of-town mansions from its early eras of development. Large, gracious trees and a wider street provide clues to the area's specialness as an address. The Fifth Avenue area also includes the blocks to the east, where the houses exhibit that same character. These houses are examples of Denton's most preserved, pure architectural styles.

### Lot Sizes

Most lots are around 70 feet wide and 100 to 120 feet deep. Corner lots may be 10 to 15 feet wider in keeping with the grand scale of this area of Denton.

### Front Yard Setback

Houses along Fifth Avenue and its adjoining blocks tend to have gracious front yard setbacks, in the range of 25 feet in depth. Buildings are set back relative to each other with only minor fluctuations. Porches may extend up to 12 feet into the front yard, but are typically 8 feet in width when present and appropriate for the architectural style. Bay windows may also extend into the front yard.

### Side Yard Setback

Side yard setbacks typically total no less than 10 feet to the property line. Driveways are minimal and understated, if present at all. Typically corner lots and other wider lots support driveways to ancillary structures at the rear of the lot.

### Side Street Setback

Houses on corner lots usually conform to the front yard setbacks, or if not, are a minimum of 15 feet. This setback reinforces the fronts of these houses.

### Garages and Ancillary Structures

Garages are located at the rear of the lot with a narrow 8- to 12-foot-wide driveway leading from the street. Garages often have carriage units or 'granny flats,' living space above the garage proper. Most of the time, these structures are built in concert with and in the same architectural style as the house itself.

### Streets

Fifth Avenue and its partner street to the east have wide rights-of-way, of approximately 50 feet. The width of the cartway, however, is usually much smaller, around 20 to 30 feet, and most adjacent public rights-of-way are well

planted and lush. Parallel parking is not typical on these streets, and though it could be accommodated, two-way travel movement is common.

### Curbs

Curbs are 6 to 8 inches tall and are typically constructed of concrete.

### Verges and Street Trees

Verges or tree lawns are typically 5 feet in width and are planted both with grass as well as other flowering plants and bushes to create a very green and lush public realm. Mature, large street trees are generally spaced 25 to 30 feet on-center and are located in both the wide verge strip, as well as the front yards. This doubling of trees provides a wonderful shaded canopy over the public sidewalks, often up to the front porch, depending on the trees themselves.

### Sidewalks

Sidewalks are made of poured concrete and are generally 4 to 6 feet wide throughout this area of Denton.

### Lighting

Overhead lighting, often linked to power poles, is used throughout this area as well as most of the residential areas of Denton. Individual houses use auxiliary lighting on porches and facades to light the way from the public sidewalk to the individual houses.

### Fencing and Garden Walls

Generally there is little fencing in this area. Often delineation of space occurs with low planting of various types instead. Lush planting takes the place of fencing and similar structures.

### Retaining Walls and Steps

Few retaining walls are present, although the approach to some houses is up a mounded front yard that lifts the house up to overlook the street. When this occurs, typically the yard is raised no more than three steps.

### Planting

Enormous old trees grace the street and add greatly to its classic character. Ornamental trees, flower beds, bushes and hedges are all present. Yards and landscaping are very well-maintained. Planting is very thoughtful, and works with the overall composition of the house.

ESSENTIAL QUALITIES OF DENTON TODAY



A Fifth Avenue house

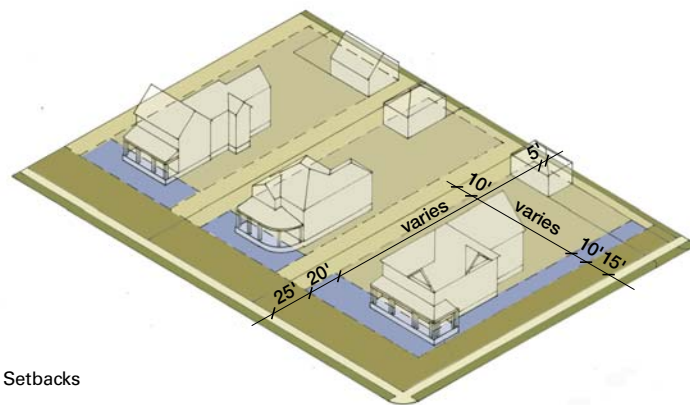

Setbacks

FIFTH AVENUE

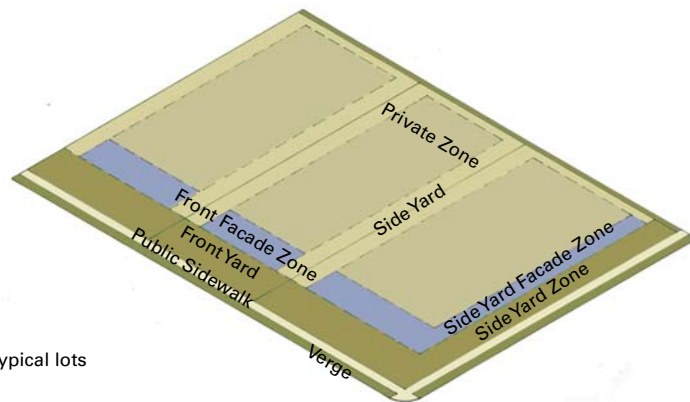
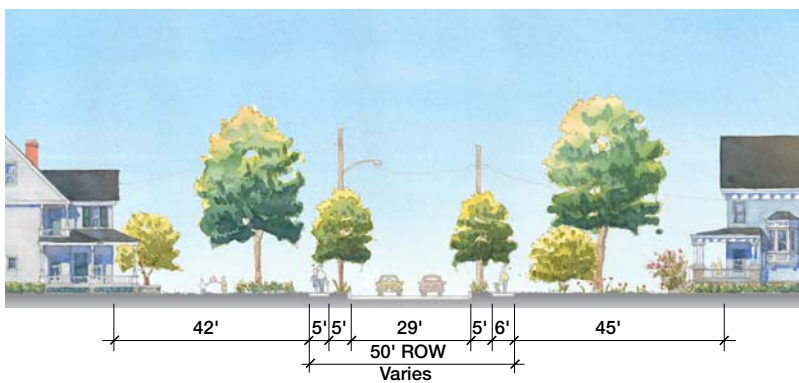

Typical lots



## South Second Street (T4/T3)

### Essential Elements

- >> Informal streets, often without curbs
- >> Long, rural sections of street with an informal street pattern
- >> Informal streetscape with few sidewalks
- >> Large trees along the street, as well as in an informal array around the lots
- >> Natural planting and landscape growth, in concert with the wooded surrounds
- >> A variety of traditional house styles, as well as later house designs
- >> Wide, more shallow lots, often wooded or influenced by the natural lands along the Choptank River



South Second Street and the blocks in its vicinity were developed in a loose, rural fashion due to their natural relationship to the Choptank River and the wooded areas south of the center of town. By the informal way that streets meet yards, and the general feel of connection to the natural environment in this area, the neighborhood fabric relates not only to the river, but its open spaces and nearby Martinak State Park to its south. Houses and the way streetscapes are handled generally defer to the natural setting around them.

### Lot Sizes

Lots are very wide in this area, sometimes wider than they are deep. Widths tend to be between 80 and 90 feet wide and 70 to 100 feet deep. Corner lots may be wider by about ten feet, and on these lots, houses tend to look as though placed at the middle of the lot.

### Front Yard Setback

The main bodies of the houses are set back 25 to 45 feet from the front property line. Porches, whenever present, are a usable depth.

### Side Yard Setback

Side yard setbacks typically total no less than 10 feet to the property line. Slip drives may require an additional 10 to 12 feet on one side of the house.

### Side Street Setback

Side street setbacks tend to be gracious like the front yard setbacks.

### Garages and Ancillary Structures

Garages are typically located at the rear of lots, accessed from the side yard on corner lots and from driveways leading from the street on in-line lots. On occasion, even less formal gravel drives loop in front of the houses.

### Streets

Streets typically have a 32-foot right-of-way, with a narrow cartway, particularly in those sections of the neighborhood that are rural in character and do not have formal curbs. Parking is allowed on one or both sides, and varies throughout this area.

### Curbs

When curbs are present, six-inch concrete curbs are typical. For those houses along South Second Street itself, front yards often meet the street informally without any curb, just a change in material.

### Verges and Street Trees

Verges are not characteristic of this area, though the area is relatively lush. Formal street trees are also not present, though there are many trees in less formal arrangements scattered around the lots, particularly as one moves south along the Choptank River.

### Sidewalks

Sidewalks are not typical in this area, and due to its less regular street pattern, pedestrians are often seen walking in the cartway of the street, due to low volumes of through-traffic.

### Lighting

Street lighting is not a common sight in these areas, with the exception of cobra head lighting attached to power poles. Houses often have lights in the front yard or on porches.

### Fencing and Garden Walls

Very few formal domestic landscape elements are present in this area.

### Planting

Foundation is typically the most formal planting found in this area of Denton. Ornamental trees, shrubbery, hedges, and flowerbeds are more prevalent. However, many lots are relatively wooded as one approaches Martinak State Park and the Choptank River.





A South Second Street house

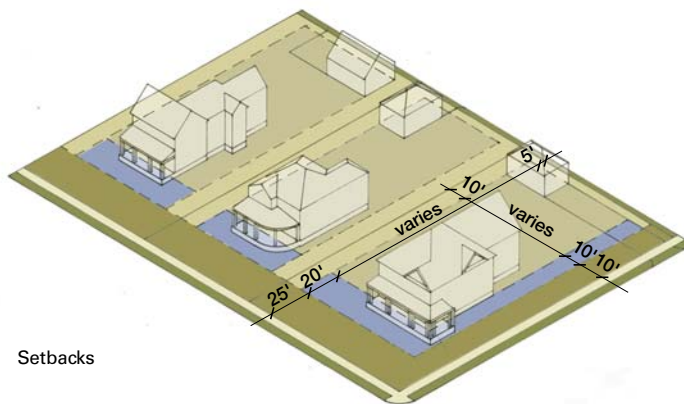

Setbacks

SOUTH SECOND STREET

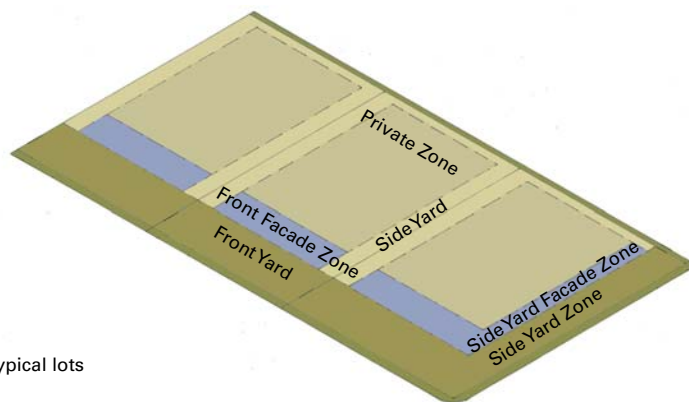
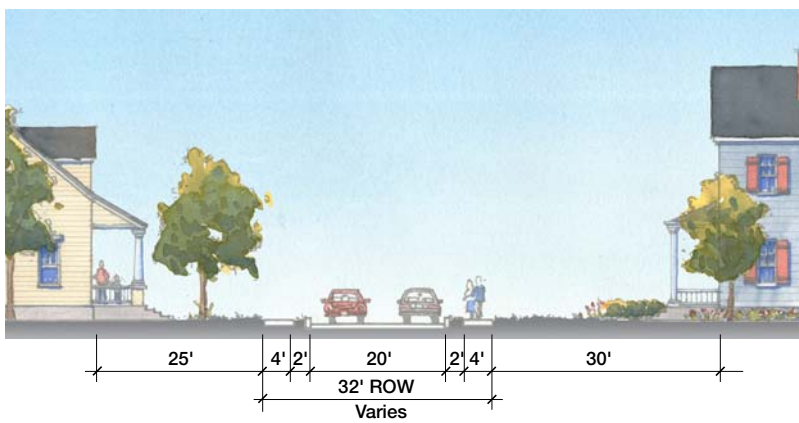

Typical lots



## Edge of Town Neighborhoods (T4/T3)

### Essential Elements

- >> Broad streets without curbs, characterized as the farm roads they used to be
- >> Widely-spaced houses, early suburban in character
- >> A lack of curbs and formality in the streetscape
- >> No verges, often smaller trees are located in the yard
- >> Tall, widely spaced cobra-head-style street lighting
- >> Minimal and sparse front yard planting
- >> Simplified architectural forms and details on smaller one- and one-and-one-half-story houses
- >> Relatively wide lots, deep front yards and wide side yards with front-loaded lots



As the neighborhoods slowly feather out from the core and the Fifth Avenue area, houses are spread farther apart and yards are a bit less formal, reminiscent of the loose quality of their farmstead era. The houses in the vicinity of Sixth Street and Camp Road, as well as those areas east of the Fifth Avenue area, exemplify a more rural pattern and feel. Historically, it is likely that the larger houses set back from the road were farmhouses, while the current, neighboring houses are later, infill lots.

### Lot Sizes

Most lots are between 55 and 65 feet wide and range in depth, though mostly 100 feet deep. Corner lots are generally wider, though in general the housing patterns are linear, along the rural roads that once led out of town.

### Front Yard Setback

Front Yard setbacks to the main bodies of houses are typically around 20 to 40 feet. Porches are found on many houses, and are usually at least 6 feet deep.

### Side Yard Setback

Side yard setbacks typically total no less than 5 feet to the property line. Lots are often front-loaded, with driveways pulling in from the street, requiring at least an additional 10 to 12 feet on one side of the house.

### Side Street Setback

A 5- to 10-foot setback is typical from the side street property line to the house.

### Garages and Ancillary Structures

Garages are usually set behind the house facade or at least equal to but not in front of it. Driveways are typically

paved in concrete and there are no carriage houses, though other small ancillary structures might be present, such as backyard sheds.

### Streets

Streets in the Edge of Town neighborhood areas have 40- to 45-foot rights-of-way. The paved cartways are wide in comparison to the neighborhoods nearer to Denton's center, typically around 30 feet. Streets have two-way movement and parking is found on both sides of almost all streets.

### Curbs

Curbs are not typical in this area, and front yards meet the paving of the street in a rather informal way.

### Verges and Street Trees

Verges and street trees are not present, although there are often a few trees in individual yards.

### Sidewalks

Rural in streetscape character, sidewalks are not typical.

### Lighting

Street lights are cobra heads and attached to power poles (not recommended).

### Fencing and Garden Walls

Fencing and walls are rarely found in this area of Denton.

### Planting

Front yards are large expanses of grass, interrupted by the occasional tree. Planting around the house is simple and straightforward with flowering shrubs and bushes.



ESSENTIAL QUALITIES OF DENTON TODAY

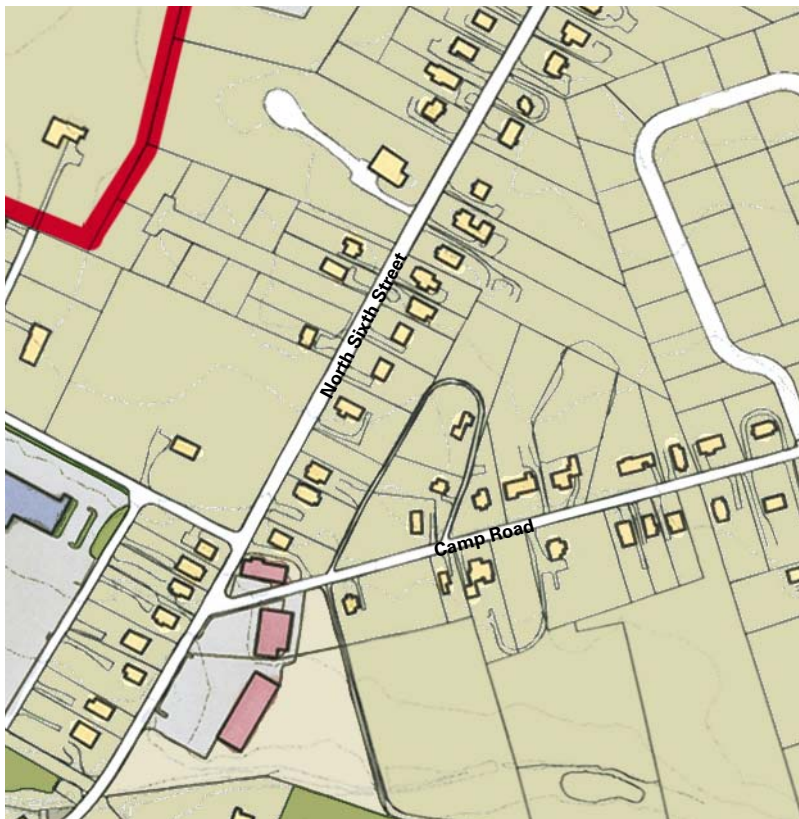

An edge of town house

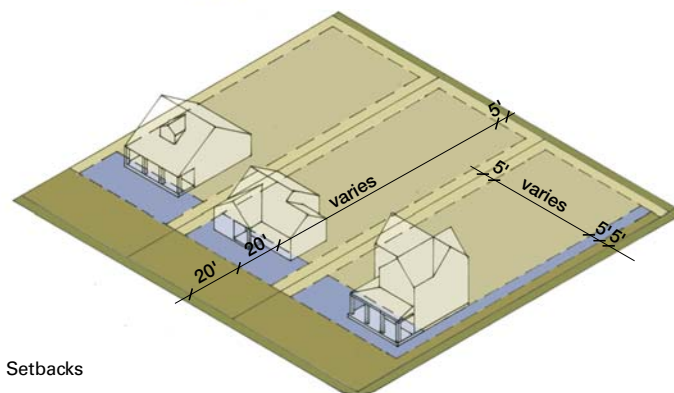

Setbacks

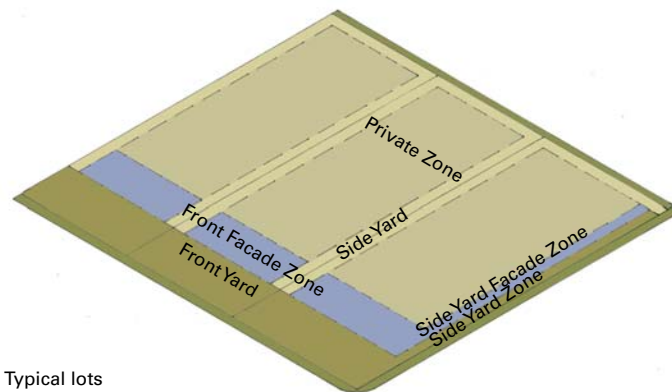

Typical lots

SIXTH STREET

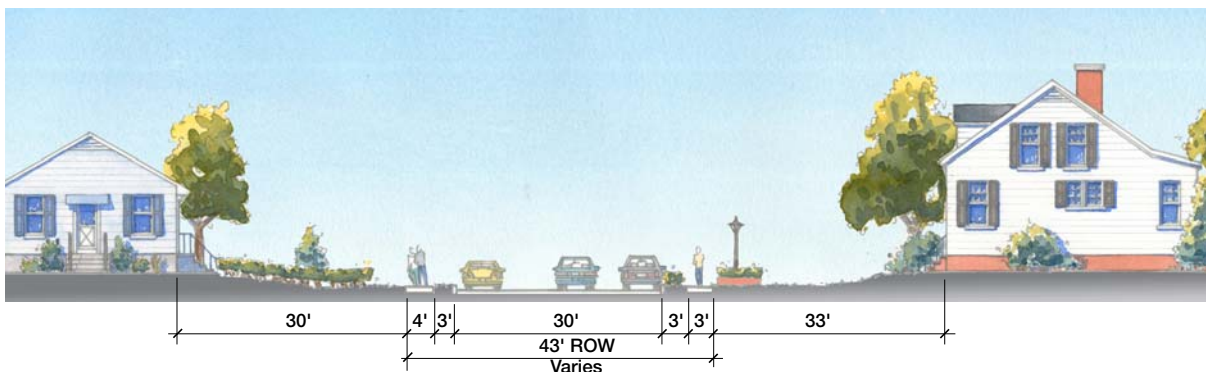

# Existing Civic Spaces



Crouse Park



Fourth Street Park



Wheeler Park

Denton has a number of fine civic spaces, among them Courthouse Square. These civic spaces range from squares to natural public parks, such as Martinak State Park, to formal streetscapes at the core of town.

## Formal Squares and Plazas

Courthouse Square is Denton's signature public space. As the seat of Caroline County, it houses the Courthouse in a formal green that also serves as a park for the downtown. Formal gathering spaces are important for any town, and they are appropriate in any number of shapes, sizes, and characters.

## Parks

Denton has a few parks that are generally co-located with schools and other institutions. Fourth Street Park is adjacent to St. Luke's Church, and near the Denton Child Development Center. In addition, Wheeler Park is located near the middle school, and has some active recreation elements. Crouse Park is located on Denton's riverfront and is being developed to better connect the town to the Choptank River. Martinak State Park, south of the core of town, contains both parks and playgrounds, as well as natural landscapes for passive recreation and connection to the natural environment of the region.

## Institutional Spaces

The schools throughout Denton have associated play-spaces and fields for the use of school children, as well as the greater community. Institutions, such as the town's churches, also have associated greenspaces, which tend to be formal gathering areas and gardens. Adjacent to the Caroline County Courthouse, the green surrounding the facility boasts large trees and areas for passive recreation.

## Streetscapes

The downtown streetscape respects the formal nature of this area. Use of brick pavers, formal and coordinated street lighting, planters, hanging baskets, and banners all bring this area together. Other elements such as benches, trash receptacles, parking meters, and other special elements in the public realm further refine the formality of the downtown.

## Wetlands

Crouse Park and the natural areas at the entry into Denton from the west, as well as the riverfront wetland areas in Martinak State Park are wonderful examples of Denton's unique environs along the Choptank River and within the Chesapeake Bay watershed. Continued stewardship and appreciation of these areas is important as they tie the town with its natural identity.



Visitors Center at Courthouse Square

ESSENTIAL QUALITIES OF DENTON TODAY



Courthouse Square



Market Street south of Courthouse Square



Martinak State Park



Crouse Park



Martinak State Park

The background of the page is a light-colored, sepia-toned aerial sketch of a town. It shows a grid of streets, numerous houses with gabled roofs, and scattered trees. The drawing style is loose and artistic, typical of a conceptual urban plan or a historical map sketch. The overall tone is warm and nostalgic.

## SECTION C

# STRATEGIES FOR NEW DEVELOPMENT

As growth continues in and around Denton, sound development strategies are essential to ensuring that the qualities of the community that are most prized – its sense of scale, its historic character, and its relationship to its treasured natural environment – are maintained and supported by both infill and new development projects.

This section of the Pattern Book contains development strategies which can help property owners and developers achieve that important goal by understanding the frameworks in which development occurs vis-à-vis the Transect Zones and the existing neighborhood patterns just described in Section B: Essential Qualities of Denton Today.

The section begins with a look at Urban Patterns for Infill which are then elaborated on in the Urban Infill Kit of Parts. After presenting development guidelines as they apply to infill projects, the section continues with Urban Patterns for New Development and the elaboration of those ideas in the guidelines recommended in the New Development Kit of Parts.

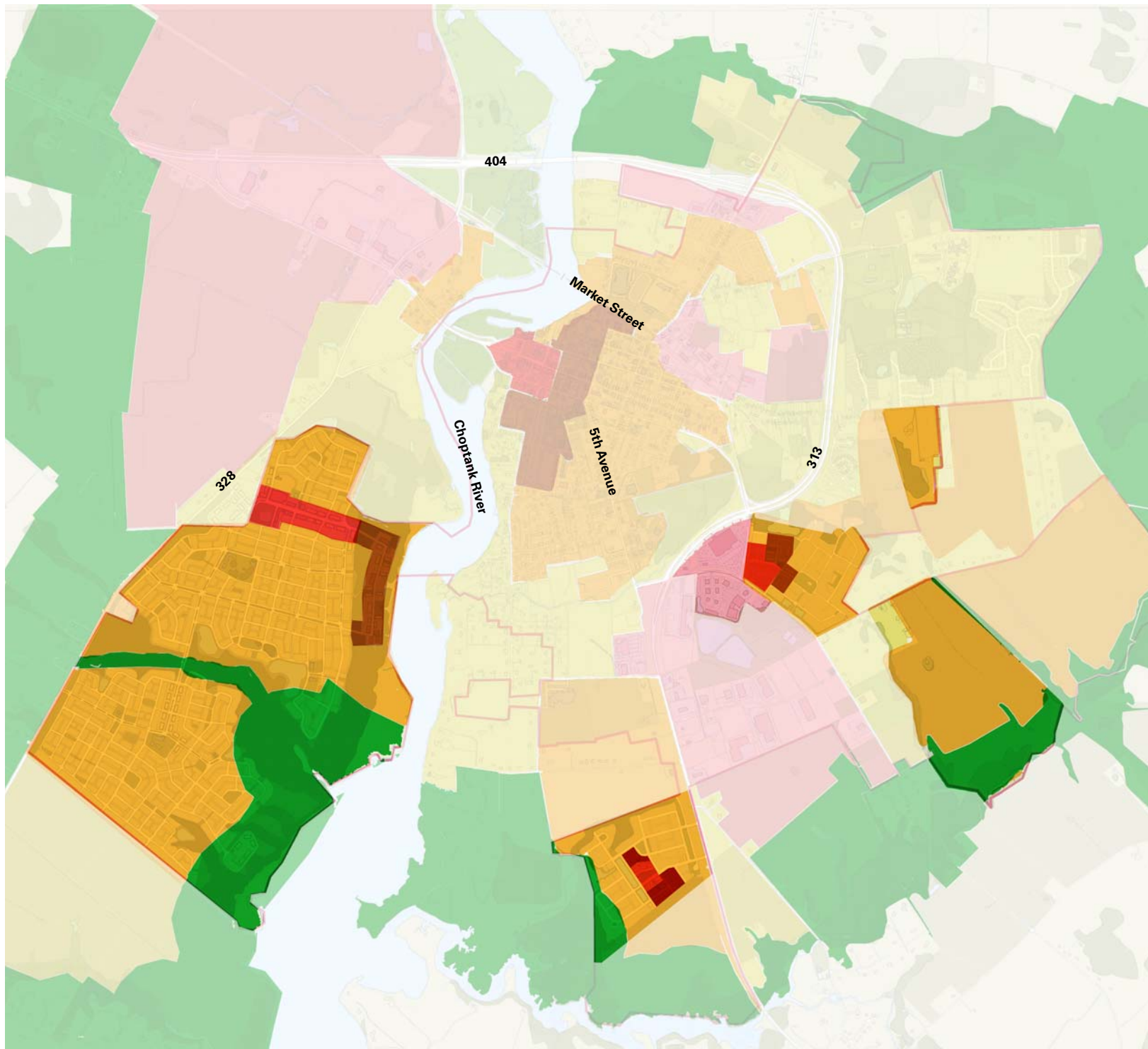

This map of Denton's Transect Zones highlights Planned Neighborhood (PN) projects, generally of a large scale, that will have areas that reflect most if not all of the transect zones within their borders. By using the principles of the Transect and the ideas contained in this Pattern Book, developers can ensure that their projects remain neighborly to adjacent uses both in scale and character.

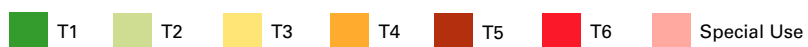

# Urban Patterns for Infill



Note: This drawing illustrates the Pattern Book design principles applied to the existing fabric of Denton. Areas of the town are depicted in a somewhat idealized state to illustrate possible infill scenarios consistent with the ideas presented in the Pattern Book. The possibilities shown in the drawing do not necessarily correlate with specific development initiatives proposed or underway.



### Introduction

Neighborhoods and towns are complex systems consisting of many different elements. The most appealing and remarkable spaces in towns are those in which harmony exists among all of the elements which create these spaces, including: the scale of the street, the widths of sidewalks, the placement and height of buildings, the architectural character, and the landscape details that add layers of richness and color. However, creating this harmony is a challenge because the responsibility for the design and development of these diverse elements often lies in the hands of different people with different scales of focus.

The existing fabric of Denton – especially that which is near the urban core – serves as a wonderful example of a complex place that is beloved by residents and visitors alike because of the way it makes them feel. This response to place is a result of the many systems of the town coming together to create an even better whole. The drawing at left of the downtown core and its closest in-town neighborhoods illustrates the important relationship among the town’s varying systems. The Urban Infill Kit of Parts which appears on the next page examines each of the elements identified above to illustrate how they are all necessary and must also work together to form a strong, positive sense of place.

### Existing Site and Town

The aerial view you see here looks southeast across the banks of the Choptank River. Downtown Denton and the Caroline County Courthouse are in the foreground. It’s easy to recognize the densest blocks of the town between Gay and Franklin Streets, from the river to Fourth Street. In all directions, the in-town neighborhoods feather outward to the less dense neighborhoods beyond. This view makes it easy to see the neighborhoods, or areas, of Denton which are alike in character and scale. Through this ability to break down the scale of the town into discrete parts, we can better understand the way in which they are put together.



# Urban Infill Kit of Parts

## Introduction

The diagrams on these two pages examine the systems that make up Denton's existing fabric. By understanding the various parts and the relationships among them, we can abstract the rules by which new infill development can fit into, connect to, and improve the fabric of the town surrounding it. As a town, Denton is formed by a collection of streets, parks, houses, and mixed-use buildings that fit within the following frameworks.

## Streets

Denton has a number of different street types. These range from larger arterials, such as Gay and Franklin Streets which carry more through-traffic, to the urban, downtown section of Market Street, to the urban neighborhood street network, to the informal, sub-urban or rural sections in the north. There are also alleyways in some blocks. For each street type, there is an appropriate cross-section that includes the width of paving, streetscape and sidewalks, lighting, and the like.

## Landscape – Streetscape and Public Open Space

Parks, playgrounds, and civic and institutional building grounds constitute public open spaces within the town. Public rights-of-way, in the form of streets, connect these amenities. The streets themselves should be developed with sidewalks, appropriate street trees, tree lawns, lighting, and other furnishings, particularly on streets with a mix of uses along them, such as Market Street near Courthouse Square. The banks of the Choptank River should also be developed with publicly accessible trails and gathering areas.



Streets



Landscape: Streetscape, Public Open Space and Natural Areas



Blocks by lot type

Residential Lots	Mixed Use Lots	Civic, Institutional and Park Land

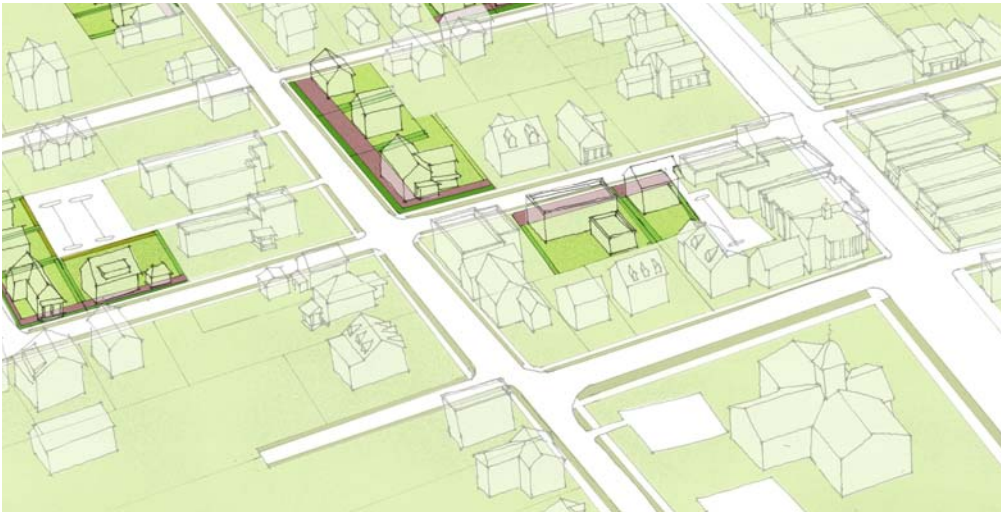

Lot Requirements: Facade zones for infill lots

### Blocks with Infill Lots

Blocks are parcels of land defined by the public streets that surround them. Blocks are subdivided into individual lots where houses sit. Infill lots are those lots where buildings do not currently sit, but which are available for development. Infill development should respect and correspond to its neighbors in character, scale, and building type, per the appropriate Transect zone.

### Lot Requirements

Buildings work best in concert along a street when they respect and coordinate with each other. Such environments are cohesive, and encourage safe, pedestrian connectivity. Neighborhoods are organized by typical setbacks and facade zones for parcels along a block face. Such lot requirements set the location of buildings and establish the character of the public realm by the relationship of buildings to one another based on these setbacks and facade zones.

### Buildings Placed on Lots

Placement of buildings on lots creates the relationship between mass and voids. The prevailing pattern along the block face and in the neighborhood significantly influences the neighborhood character. Extreme deviations from prevailing patterns disrupt these existing relationships.



Buildings placed on lots

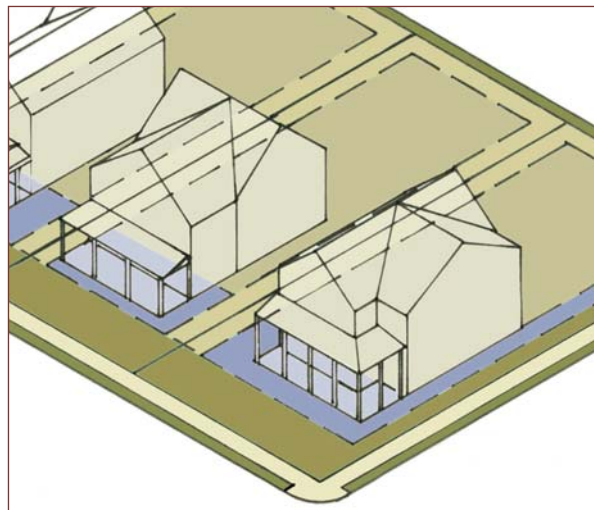

Buildings

# Urban Patterns for New Development



Note: This drawing illustrates the Pattern Book design principles within a Planned Neighborhood Zone. Areas are depicted in a somewhat idealized state to illustrate ideas presented in the Pattern Book and do not necessarily correlate with specific initiatives for the development of West Denton.



### Introduction

As noted previously, neighborhoods and towns are complex systems consisting of many different elements. Providing for cohesion and a healthy relationship among these systems in the design and construction of new places is essential to their success. Creating harmony among the varying elements of a new development, particularly large-scale developments, can be challenging, but is essential to tie the place together, as well as connect it back to the associated town.

Although new large-scale development in growth areas will occur largely outside historic Denton, such developments are still inextricably linked to the town. To complement Denton’s historic character, new development must feel as though it has been coordinated and developed over time, even though actual development time may be relatively short.

The feeling of community will only emerge if the many systems making up the development come together synergistically. You’ll find the supportive systems which must be coordinated for new development to work successfully elaborated on the next two pages.

### Prototypical Development

This aerial view looks northwest across the banks of the Choptank River toward the West Denton development. Presented here simply as a prototypical example, the plan is overwhelmingly residential in character and defined by the natural systems which frame it, yet it also contains a core of denser residential and mixed-use building types, as well as commercial development. Diagrams on the next two pages break the development plan into its coordinated systems to identify the areas that developers and builders will need to think about in order to create rich new built environments.

### Building Types

To satisfy today’s marketplace needs – which are different in social and cultural context than those in place when the historic town of Denton was developed – several new building types are being introduced in this Pattern Book. These types are detailed in Section D: Building Types. In all cases, building types must be selected based on their appropriateness to the Transect zones embodied in the development and also must adhere to the architectural styles prevalent in Denton and the surrounding historic towns of the Maryland Eastern Shore.



# New Development Kit of Parts

## Existing Site

Denton and its immediate surrounds feature a number of waterways and wetlands that reach in from the Choptank River. These natural features define the buildable areas in which new development can occur and also provide wonderful natural amenities and addresses for development that can capitalize on the presence of the nearby river. One example is the West Denton development, just west of the existing historic town and connected to it by the main bridge into town which leads to Market Street.

## Open Space and Connectivity

Using the open space network as a framework for development provides opportunities for environmentally-sensitive design that works in concert with the natural elements that define the area. The riverfront should be maintained primarily for public access to the Choptank, while streams reaching inward can provide unique neighborhood development addresses. Development blocks are defined and connected by tree-lined streets. Institutional lands and park spaces are interwoven and accessible to residents of the new development via the sidewalks and pedestrian connections throughout the plan. Parks should be scaled to serve their placement in the neighborhood, and a general diversity of parks and civic spaces should be incorporated into new places.

## Neighborhoods

As with any large greenfield development, a series of neighborhoods must be established to lend character to the development and create a human scale that is pedestrian friendly. These neighborhoods form residential subsets of the larger community through a series of interconnected blocks that are generally consistent in character.

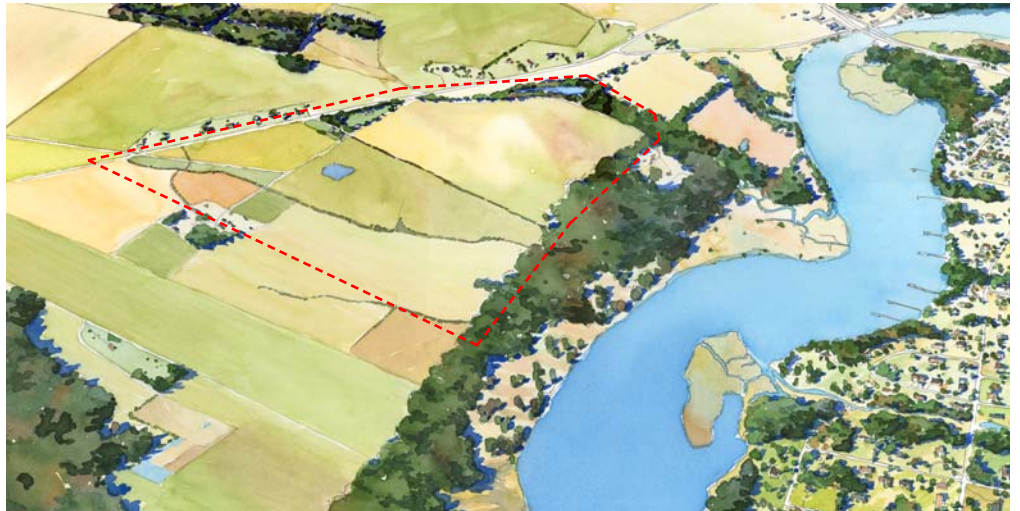

Existing site and town

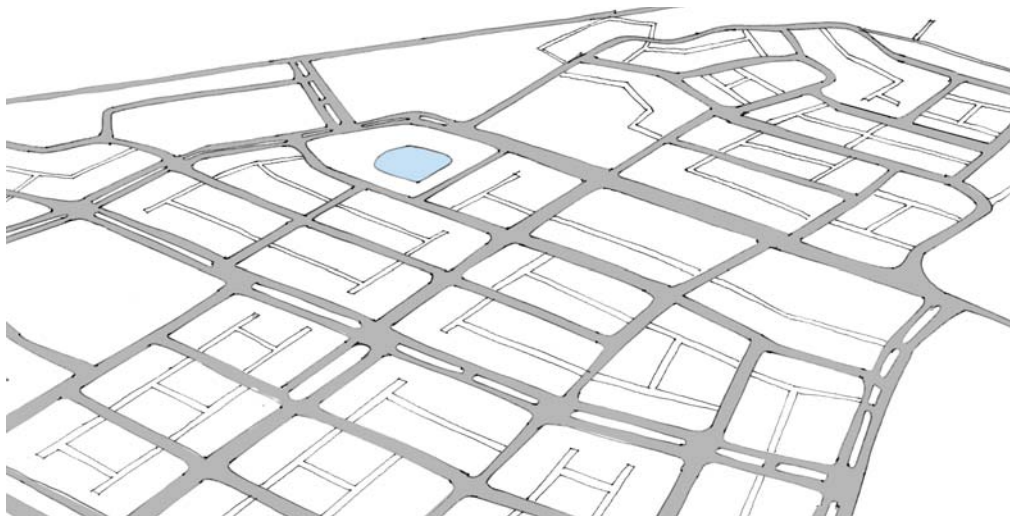

Open space system with green infrastructure, street, and pedestrian connectivity



Neighborhoods



Blocks with Lot Types

<span style="color: orange;">■</span> High-Density Residential Lots	<span style="color: green;">■</span> Civic, Institutional, and Park Land
<span style="color: yellow;">■</span> Medium-Density Residential Lots	<span style="color: pink;">■</span> Mixed-Use Lots

### Blocks and Lots

A variety of block and lot sizes are needed to accommodate the wide variety of building types that add richness and broad-based marketplace attractiveness to large-scale new developments. House lots, for both single-family and attached products such as duplexes and triplexes, generally radiate from the core of such developments, which typically consist of higher density residential buildings, live/work units, and mixed-use and commercial buildings. Blocks are subdivided into lots appropriate for their Transect zone and location in the plan and within the particular block.

### Lot Requirements

Standard setbacks and facade zones are enforced to create a cohesive environment across a block face. Though the same requirements are implemented on all blocks, the menu of setbacks vary across a plan to create a variety of consistent environments with understandable and replicable character.



Lot requirements

### Buildings Placed on Lots

Building types are scaled to fit on appropriately-sized and located lots. Buildings should be in the style and character of Denton although some types may not be found within historic Denton. Appropriate precedents may be sought from nearby Eastern Shore towns for variations and types not included in the fabric of historic Denton.



Buildings placed on lots

The background of the page is a light-colored, sketch-style aerial view of a town. It shows a variety of building footprints, some with gabled roofs, some with flat roofs, and some with multiple stories. There are also numerous trees scattered throughout the town, and some streets or paths are visible. The overall style is architectural and illustrative.

## SECTION D

# BUILDING TYPES

With the growth and new development that Denton is experiencing and will continue to experience, both within and at its current edges, a discussion of appropriate building types and their applications is essential to channeling new growth in a way that is fitting for the fabric of the town. Building types are not just based on use, but also on the scale and massing of their forms. They are also always changing to meet new market demands. New building types, such as large multi-family apartment buildings, multi-unit condominium buildings, and large-scale commercial buildings, have become the standard for current development patterns.

In this section, a number of different building types will be discussed in terms of their appropriate siting and key elements within the existing town or new developments. Suggestions are also presented for addressing site planning criteria and building form issues relating the various building types to their surroundings.

# Building Types and the Transect

As described previously in Section B: Essential Qualities of Denton Today, the Transect of Denton provides a useful framework in which to discuss where to place different building types to ensure that they are appropriate to the character of the neighborhood or district in which they are placed. For example, mixed-use buildings are not appropriate for all of Denton's neighborhoods; however, their development in the T5 and T6 zones works well near the existing core of town.

The tables on this page map out the Transect Zones, characterizing the various parts of Denton by their corresponding T-zone, and also identify the appropriate Transect zones for each of the building types. By cross-referencing these two tables, one can understand the appropriate places and relationships between buildings of differing form and massing.

T3	T4	T5	T6	Neighborhood
				Courthouse Square and Downtown Market Street
				In-Town Neighborhoods
				Fifth Avenue
				South Second Street
				Edge of Town Neighborhoods

T3	T4	T5	T6	Neighborhood

T3	T4	T5	T6	Building Type	Image
				Civic Buildings	 
				Large-Scale Commercial	 
				Mixed-Use & Multi-family	 
				Townhouses & Live/Work	 
				Attached Housing	 
				Single Family	 
				Carriage Houses	 

## Civic Buildings

Civic buildings house the services and institutional uses that bring people together. Municipal structures, cultural facilities, libraries, churches, schools, community centers, visitor centers, and membership organizations constitute civic buildings.

### PLACEMENT IN TOWN

- >> Place on prominent, visible, accessible sites of importance
- >> Locate civic buildings to terminate vistas and along major axes
- >> Make structures central to as many residential neighborhoods as possible

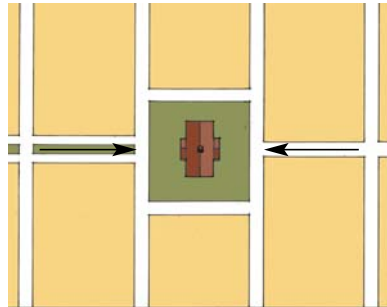

### SITE PLANNING

- >> Orient building fronts to major axes, vistas, and approaches
- >> Integrate with neighboring land uses
- >> Clearly define approach and access to buildings
- >> Create useful outdoor space or garden rooms that can be used for associated functions
- >> Site useable or celebratory outdoor areas in obvious locations
- >> Plan for parking and loading at the backs or sides of buildings, and screen these areas with low walls and landscape elements

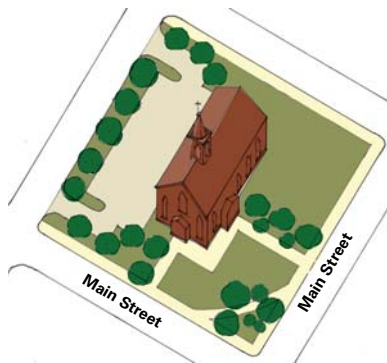

### BUILDING ELEMENTS

- >> Provide civic stature through the use of architectural elements and solid, appropriate materials
- >> Allow the forms and massing of the architecture to blend in with Denton's architectural character and human scale
- >> Make entries easily accessible and obvious
- >> Animate the facades of the building with windows, doors, or architectural elements as appropriate for its use so that it is a good neighbor to the scale of nearby houses and has a human scale



## Civic Spaces

Civic spaces range in scale and type. These civic gathering spaces should be designed in shapes and sizes appropriate to their place in town, neighboring uses, and the needs and desires of residents. Historic Denton includes a variety of good examples

### Community Park

#### PLACEMENT IN TOWN

- >> On the edges, not centers, of neighborhoods
- >> Often co-located with schools, institutions, and large open spaces, such as natural areas



A Community Park

#### SITE PLANNING GUIDELINES

- >> Include active recreation fields
- >> Edges should be defined by streets and faced by houses
- >> Typically one or two per town

### Neighborhood Parks

#### PLACEMENT IN TOWN

- >> Typically one per neighborhood
- >> More intimate, residential scale



A Neighborhood Park

#### SITE PLANNING GUIDELINES

- >> Edges defined by streets and faced by houses
- >> Generally passive areas
- >> Small, active recreation uses could include small playgrounds

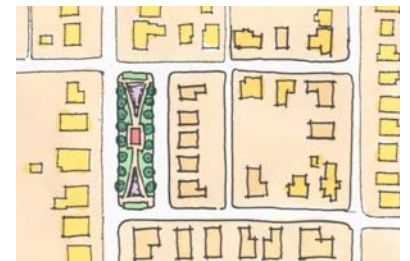

A Pocket Park

### Pocket Parks

#### PLACEMENT IN TOWN

- >> In the center of neighborhoods
- >> Very intimate scale

#### SITE PLANNING GUIDELINES

- >> Edges defined by streets or sidewalks, and faced by houses
- >> Create unique addresses within residential neighborhoods
- >> Generally passive recreation areas, including seating, fountains, or community gardens

# Large-Scale Commercial Buildings

The large scale of chain stores raises many challenges for integrating them into new places, particularly in urban fabric. Typical corporate plan layouts and architecture often do not lend themselves to sensitive siting and place-specific architecture.

## PLACEMENT IN TOWN

- >> Locate in Transect Zones T3 and T4, or single-use, special purpose districts, with an emphasis on form and massing
- >> Preferred location is in T4 where the urban fabric is robust and can incorporate larger-scale structures.
- >> Buildings should back up against like uses whenever possible to eliminate the presence of loading docks and blank facades on streets

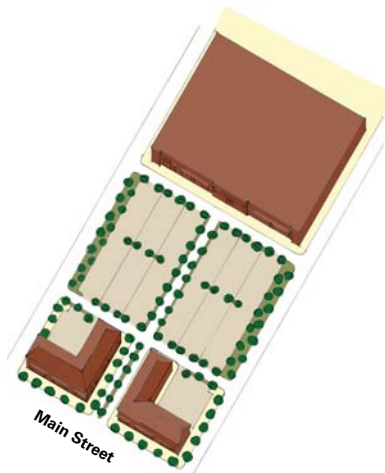

T3 model

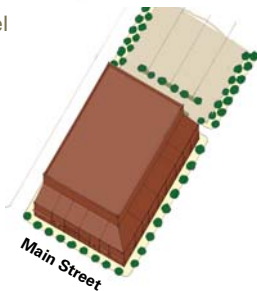

T4 preferred model

## SITE PLANNING

- >> Encourage 'liner' uses along the expanse of the large building facades.
- >> Stormwater management should be integrated into site design, rather than the creating ponds
- >> Parking should not dominate the approach and should be screened
- >> Arrange associated buildings to create nodes versus strips of development
- >> Trails, sidewalks, and bicycle connections should be clear and safe



## BUILDING ELEMENTS

- >> Main entries should be obvious yet not overbearing in architectural expression
- >> Active uses and non-associated storefronts should line the sides of the box with active uses
- >> Signage and lighting should be understated and human-scaled
- >> Architectural elements should break down the scale of the facade, particularly in a bay rhythm related to the scale of adjacent buildings

# Mixed-Use and Multi-family Buildings

Mixed-use buildings anchor downtown areas while relating to adjacent residential neighborhoods through their smaller size and proportioning. The mix of uses may include retail, commercial, office, institutional, and residential – often vertically integrated. Multi-family buildings provide a transition in size and use between downtown areas and residential neighborhoods. In Denton, a diversity of building size is critical to maintaining scale.

## PLACEMENT IN TOWN

- >> Locate in Transect Zones T6 and T5, respectively
- >> Develop greatest density at the core of the existing town, or at the cores of new developments and planned neighborhoods
- >> Arrange these buildings to face across a street, or cluster to provide local synergies
- >> Create a diversity of building scales, particularly for multi-family buildings

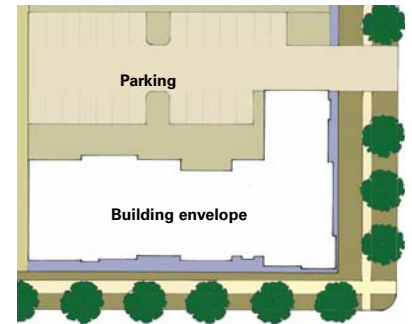

## SITE PLANNING

- >> Building height should not exceed two and a half tall stories, as characterized in downtown Denton
- >> Multi-family buildings should be of varying sizes – 6, 12, and 24-unit buildings, and should be mixed on the street face
- >> Buildings should address the street
- >> Accommodate parking and loading at mid-block or at the rear of buildings; on tight sites, delivery from the street via hand-truck should be used
- >> On-street parking should be provided for short-term use

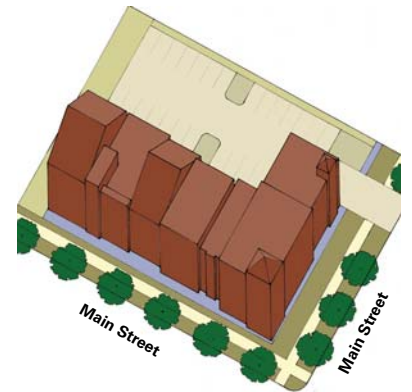

## BUILDING ELEMENTS

- >> Large buildings should be broken down into bays reflecting the existing building rhythms along Market Street in downtown Denton
- >> Large expanses of glass – shopfronts, doors, and windows – should address the street as the primary public realm.
- >> Building elements, such as awnings, lighting, and signage, can be used to create a human building scale that invites activity



## Townhouses and Live/Work Buildings

Though relatively common in other Eastern Shore towns of a larger scale, such as Cambridge and Easton, Denton does not currently possess townhouses or live/work units in the traditional, attached forms. Therefore, much care should be taken with the development of scale and architecture. Precedents from the surrounding towns should be studied.

### PLACEMENT IN TOWN

- >> Locate in Transect Zones T4, T5, and T6 because of their density
- >> Create specific, individualized areas or addresses in scripted, arranged clusters
- >> Design two-story townhouses when placing in or near existing fabric to match building heights

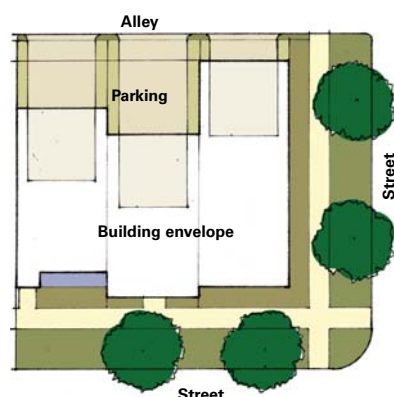

### SITE PLANNING

- >> The height should not exceed two tall stories; when three stories are desired, these should relate to other buildings of the same or greater scale
- >> Lengths of more than four running units are discouraged
- >> Buildings should face all streets and be built close to if not at zero-set-backs; they may have small gardens or lawns in front
- >> Parking should occur in the rear of the lot in separate garages or parking pads, or tucked under the units and accessed from alleys
- >> Consistent rows of street trees and sidewalks should ring residential blocks providing pedestrian connectivity

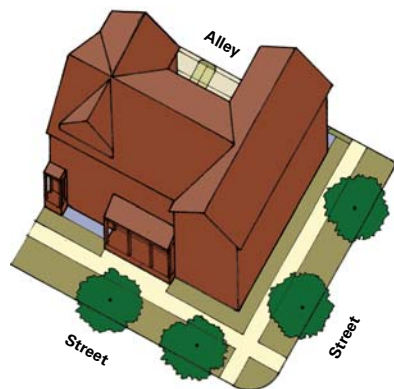

### BUILDING ELEMENTS

- >> Develop bay rhythms similar to Denton mixed-use buildings and housing
- >> Provide porches in order to fit in with the character of Denton
- >> To provide variety along the street, use architectural elements (porches, bay windows, roof elements) that fit into one of the specified architectural styles

## Attached Housing

Attached housing is found throughout Denton. Typically such houses are designed to look like larger single-family homes, and fit easily into the character of a neighborhood street. Duplexes and triplexes are the most common forms of attached housing.

### PLACEMENT IN TOWN

- >> Locate in Transect Zones T4, T5, and T6
- >> Locate attached housing on infill sites in residential neighborhoods to emulate single-family house placement
- >> Locate attached housing on infill sites in the core of Denton to increase density in a form complementary to the housing nearby

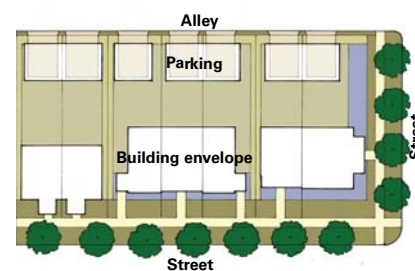

### SITE PLANNING

- >> The scale should not exceed two and one half stories, and floor-to-floor heights should be similar to those in the surrounding houses
- >> Long lengths of block faces with similarly-scaled units are not acceptable; attached housing should be scattered throughout the neighborhoods
- >> Buildings facades and front doors should face all streets
- >> Parking should occur in garages or on parking pads at the rear of the lot; units should be serviced from alleys
- >> Consistent rows of street trees and sidewalks should ring residential blocks providing pedestrian connectivity

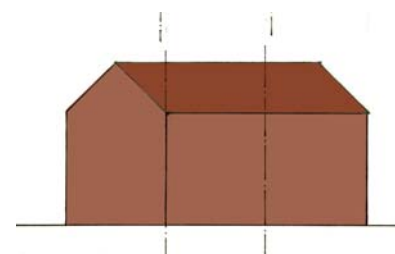
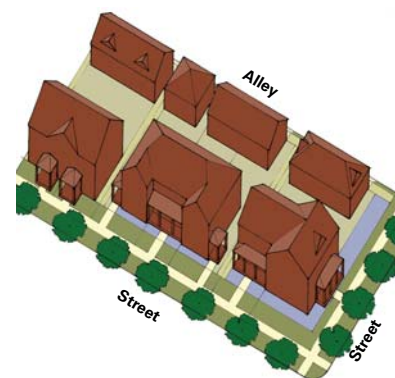

### BUILDING ELEMENTS

- >> Attached housing should be developed in the form of a large house, to maintain a residential character
- >> Where possible, attached units should have individual entrances separated by porches or wings
- >> To provide variety along the street, use architectural elements (porches, bay windows, roof elements) that fit into one of the specified architectural styles



# Single-Family Houses

The single-family house is the predominant building type in Denton, and is one of the smallest units of residential development. Single-family houses can be developed at varying scales in all of the appropriate styles and architectural vocabularies.

## PLACEMENT IN TOWN

- >> Locate in Transect Zones T3, T4, and T5 at different block densities
- >> Single-family houses occupy lots of 35 to 80 feet in width, at a variety of depths

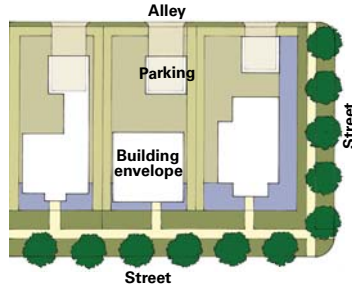

## SITE PLANNING

- >> The scale should not exceed two stories, and floor-to-floor heights should match those of surrounding houses
- >> Building facades and front doors should face streets
- >> Parking should occur in garages or on parking pads at the rear of the lot; units should be serviced from alleys
- >> If site conditions require front-loaded access, garages should be detached to the rear of the lot with a narrow, inconspicuous driveway along one side of the house
- >> Consistent rows of street trees and sidewalks should ring residential blocks providing pedestrian connectivity

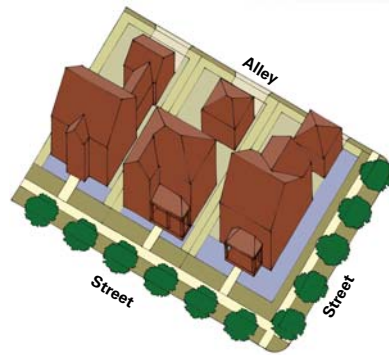

## BUILDING ELEMENTS

- >> Attached housing should be developed in the form of a large house, to maintain a residential character
- >> All units in a building should have porches, fitting with the character of Denton
- >> Architectural elements (porches, bay windows, roof forms) should be used to provide variety from the street
- >> All building architecture should fit into one of the specified architectural styles



# Carriage Houses

Carriage houses, or granny flats, provide small, flexible living in separate, units adjacent to the main house. Carriage houses provide rental housing opportunities for home owners.

## PLACEMENT IN TOWN

- >> Locate in Transect Zones T3, T4, and T5, in association with a single-family house
- >> Place carriage units behind or beside the main house on the residential lot

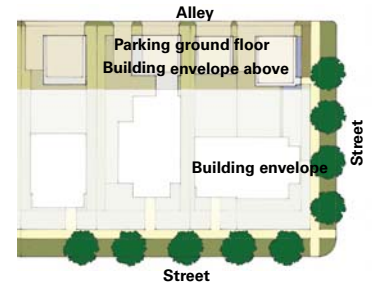

## SITE PLANNING

- >> The scale of the buildings should not exceed two stories, parking on the ground level with living space above, connected by a stair
- >> Units may face either the alley or the backyard of the main house in their orientation
- >> Parking, by definition, occurs under the residential unit
- >> Carriage units may be approached by a front-loaded driveway or from a rear alley



## BUILDING ELEMENTS

- >> Carriage units should have high ceilings to give a larger sense of scale to the unit
- >> Carriage units should utilize numerous windows to naturally light and ventilate the unit
- >> Units must have ground access by an internal and/or external stair
- >> The architectural style should be developed in association with the style of the main house on the lot
- >> New carriage houses should be designed with residentially-scaled elements and the specified architectural styles



## SECTION E

# ARCHITECTURAL PATTERNS

This section of the Pattern Book is intended to help developers, builders, and home owners understand the key elements that contribute to the character of a Denton house. The section contains guidelines for the detailing of new housing, as well as strategies for renovating existing houses in a manner that ensures that these houses will be appropriate for Denton and harmonious with neighboring structures.

The section begins with the overview on the facing page of the three predominant, traditional architectural styles found in Denton – Victorian, Colonial Revival, and Craftsman. These three styles make up nearly all of the current building stock in Denton. The Victorian style is the most prevalent; however, many fine examples of the other styles exist in the area and all three are appropriate vernaculars in which to build in the town.

Historically, Denton possesses a limited variety of building types. Additional types are being introduced through current and planned future development. Particular attention must be given to the architectural detailing of these new types in order to integrate them successfully into the fabric of the community.

Following the overview, each of the three architectural styles is described in more detail in both written and graphic form. Information is presented about the massing and composition and typical wall sections and eaves appropriate for each style, as well as the types and arrangement of windows, doors, porches, and materials that are in character with the individual styles.

The architectural details offered are meant to be used to compose elevations of new buildings and also to serve as a menu of appropriate elements for existing house renovations in the form of additions and broader transformations. For older, traditional Denton houses, or for home owners wishing to address their houses' exteriors, the renovation pages in Section G: Home Owner's Guide, contain basic rules that can help preserve and enhance the original character of the houses. If you are building a new house within one of the traditional Denton neighborhoods, new house plans can be adapted to reflect one of these traditional styles.

This section concludes with Architectural Resources – list of national Material Manufacturers who may be useful to you in sourcing materials – and also a brief discussion of Materials and Methods.

# Denton Architectural Styles Overview

Just as neighborhood character and building types contribute to creating distinct neighborhoods in Denton, so do the three most frequently used architectural styles: Victorian, Colonial Revival, and Craftsman. These styles and variations on these styles can be found in almost every Denton neighborhood.

Post-war houses, built for the many young GIs returning after the Second World War, often incorporated simplified details from these styles. As a result,

many post-war houses lack a distinctive style all their own. Through transformation, however, these houses can adopt a house style by applying the detailing found on the upcoming pages to renovation, addition, or transformation projects. If you are contemplating this type of project for your house, you'll want to combine the information contained in this section of the Pattern Book with that presented in Section G: Home Owner's Guide.



Victorian Possibility



Fifth Avenue



Market Street

DENTON  
VICTORIAN



Colonial Revival Possibility



Courthouse Square



North Second Avenue

DENTON  
COLONIAL REVIVAL



Craftsman Possibility



Market Street



North Second Avenue

DENTON  
CRAFTSMAN

**Essential Elements of the Denton Victorian**

- >> Simple house massings with symmetrical, balanced facade compositions
- >> Steeply pitched, front-facing gable roofs
- >> Cut wood ornament to more simple, 'farmhouse' details
- >> Wood siding painted in a variety of related colors
- >> Narrower, vertically proportioned windows and doors
- >> Porches with delicate, spindle-like columns and narrow balusters, when present
- >> Architectural expressions like bay windows and occasional turrets



## DENTON VICTORIAN



The Victorian was the predominant house style at the height of Denton's development and was most popular during Denton's building booms. This style builds on the simpler, farmhouse forms found throughout the agricultural lands and farmsteads which dot the country roads between Eastern Shore towns. Denton's examples range from large, ornate family houses to those based on designs in Pattern Books published by Andrew Jackson Downing. All of the local examples reflect the same root architecture and design elements typical of Victorian houses throughout Maryland's Eastern Shore. These earlier pattern books made it easier for the builders to replicate the high-style of the era and populate whole towns with predominant architectural vocabularies. Denton is, unmistakably, a Victorian town in which there are many fine examples with subtle variations in massing and more creative porch details, special moldings, and ornament in some areas. Though the ornament is more restrained than that often referred to as 'gingerbread,' the town uses a rich palette of paint and trim colors that further express its Victorian character.

ARCHITECTURAL PATTERNS : DENTON VICTORIAN



# Massing and Composition

## Narrow Front

- >> Rectangular volume with a roof pitch ranging from 8 to 12 in 12 for the main body. Porches are typically added on the front as either full front porches or wraparound porches.
- >> Compositions are generally symmetrical and consist of two, three, and five bays; the two and three bay types are the most common.

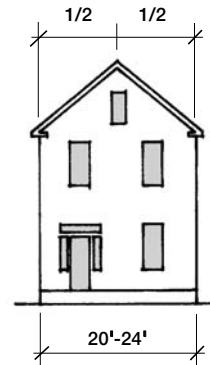
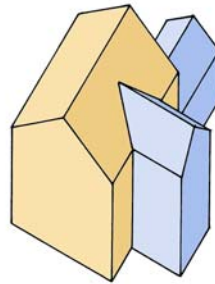
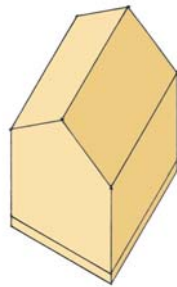

## L-Shaped

- >> Houses with a narrow, gable-end wing with an 8 to 14 in 12 gable facing the street. The width of the gable facing the street is typically one-third to two-thirds that of the main body.
- >> Massing typically accommodates a one-story continuous porch that follows the plane changes in the facade, with a shed or hipped roof.

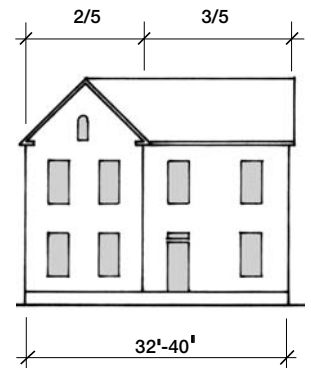
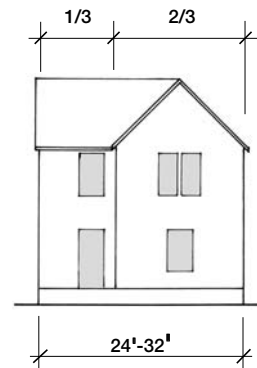
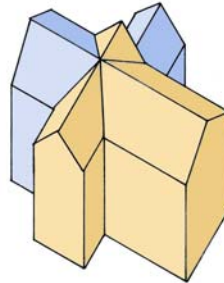
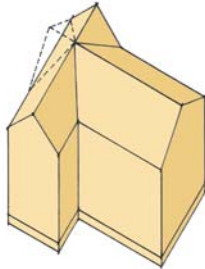

## Gable L/Pyramidal

- >> Square volume with an often pyramidal, hipped roof from which a front-facing gabled wing extends. Roof pitches range from 8 in 12 to 12 in 12. Front porches extend the full width of the facade and often wrap the side(s).
- >> The width of the street-facing gable typically dominates the facade width.

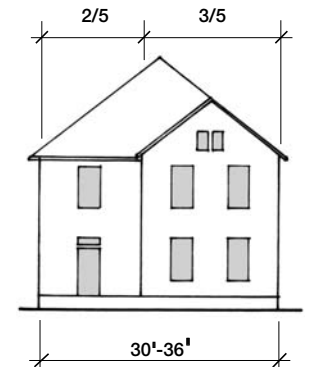
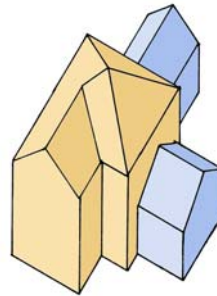
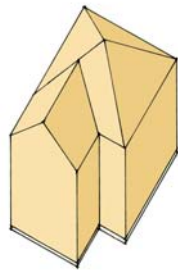

## Side Gable

- >> Rectangular volumes with roof pitches ranging from 8 in 12 to 10 in 12. One-story shed porches are often placed symmetrically on the front facade.
- >> One-story side wings often occur.
- >> Massing typically accommodates a one-story continuous porch with a shed or hipped roof.
- >> The least common massing for Denton, though some examples occur.

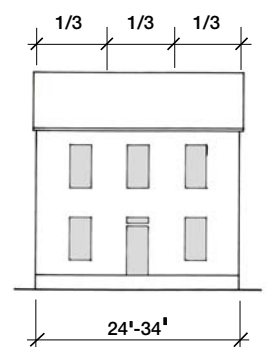
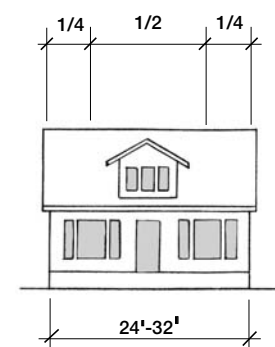
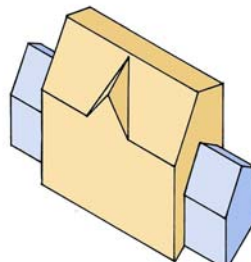
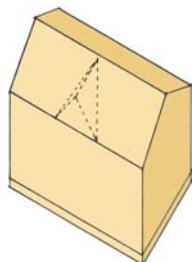

# Typical Wall Sections and Eaves

## Roof

>> The roof pitch on most Denton Victorian houses varies from 8 to 14 in 12.

## Eaves

>> Two eave types are typical: boxed eaves with frieze and boxed eaves with sloped soffit.

>> Boxed eaves have a 12- to 16-inch frieze board either touching or at least 8 inches above the window head trim. Eave returns should have metal flashing back to the wall at a maximum slope of 2 in 12.

>> Boxed eaves with sloped soffit, often hipped, at gables feature an overhang with simple decorative vergeboard.

## Wall Section

>> For one-story houses, the floor-to-ceiling height should be 9 to 10 feet. For two-story houses, the minimum floor-to-ceiling height is 10 feet for the first floor and 9 feet for the second floor.

>> Window head heights should be 8½ feet above the floor for first floor windows and 8 feet for second floor windows.

## Base

>> The first floor of the Denton Victorian house is set three feet above finished grade. Houses occasionally have an 8-inch skirt board. When foundation vents are used, they should be centered under windows.

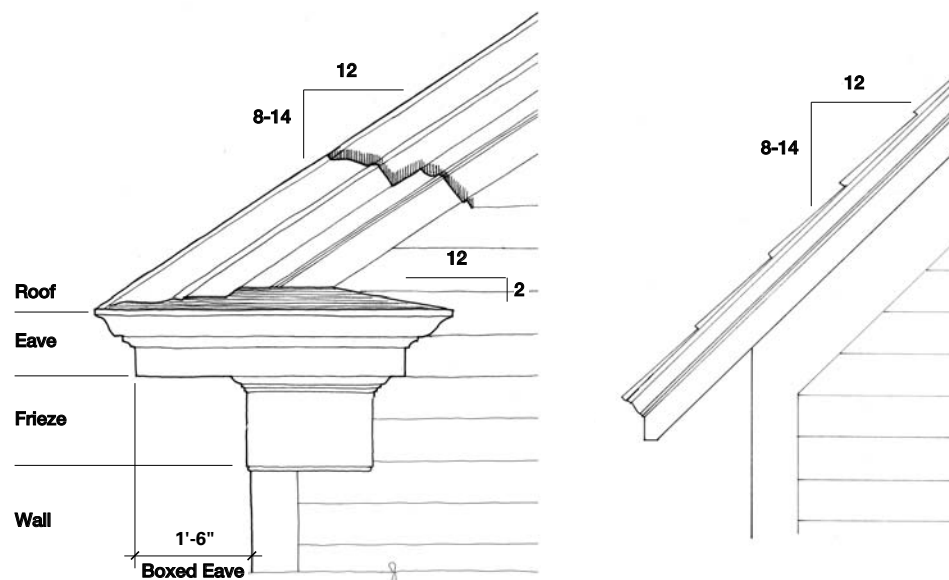
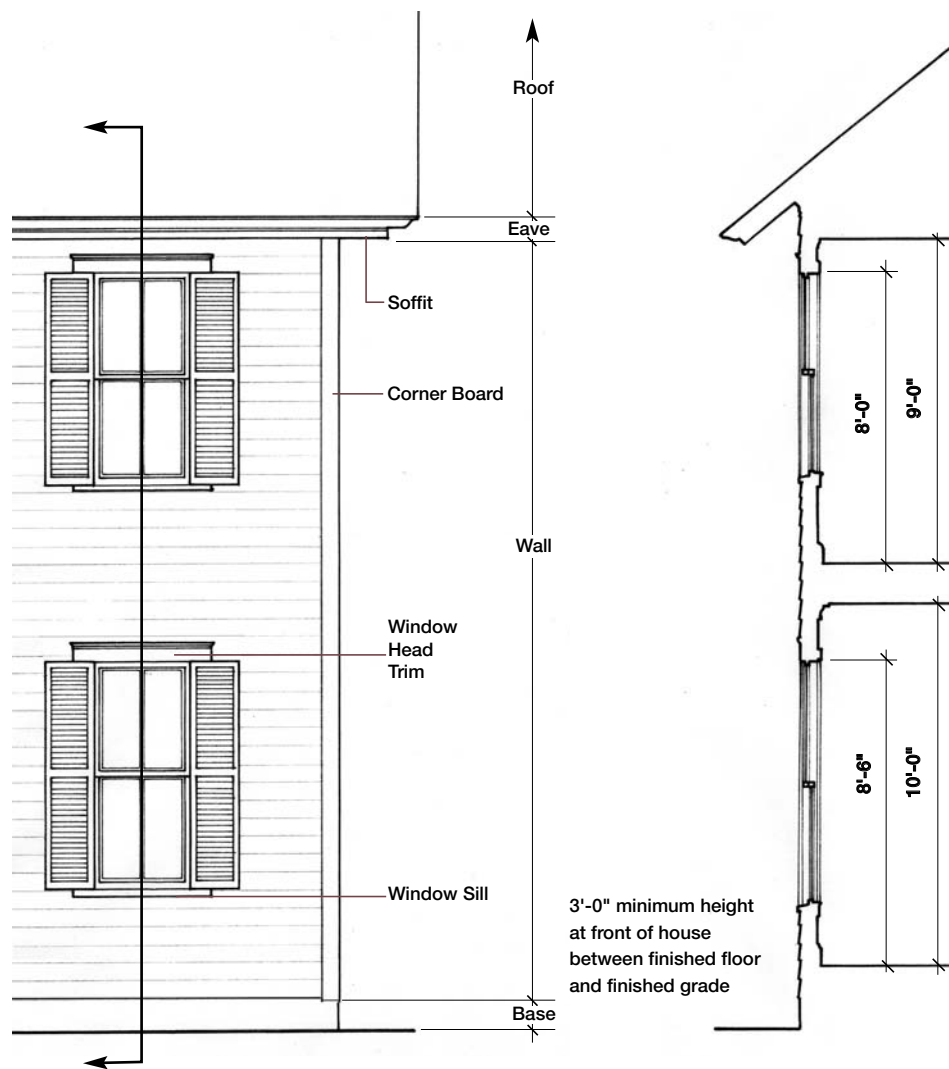

# Windows and Doors

## Standard Windows

- >> Windows are vertical in proportion and have a 2 over 2 or 1 over 1 muntin pattern; 2 over 2 is the most prevalent, and is preferred.
- >> Panes are always taller than they are wide. Standard windows are double hung.

## Special Windows

- >> Some Denton Victorian houses feature round-top windows, box and angled bay windows, and shaped louvers in attics. Bay windows must project a minimum of 8 inches from the main structure and have a continuous base to the ground; two-story bays are common.

## Shutters

- >> Shutters should be operable and in proportion with the windows they serve.
- >> Shutters bring accent colors to the facades.

## Doors

- >> Four-panel and six-panel patterns are common, two-panel patterns with glazing in the upper panel are also common.
- >> Often transoms appear above doors and lend themselves to the narrow Victorian proportions.

## Trim

- >> 4- to 6-inch trim is typical with simple or limited numbers of profiles or a simple backband profile.
- >> Window and door trim carries a decorative crown and cap above.

## WINDOWS



## SPECIAL WINDOWS

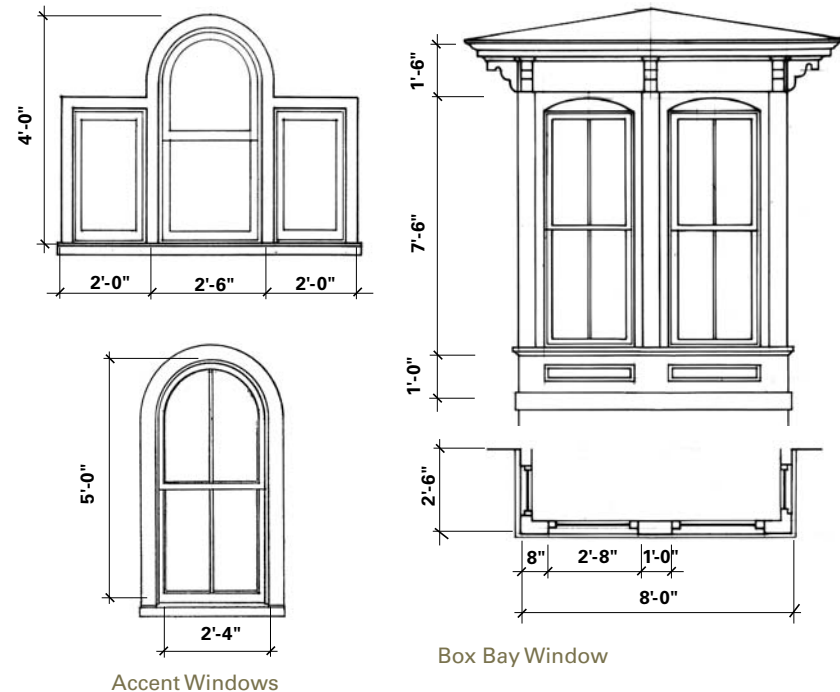

## TYPICAL WINDOW DETAILS

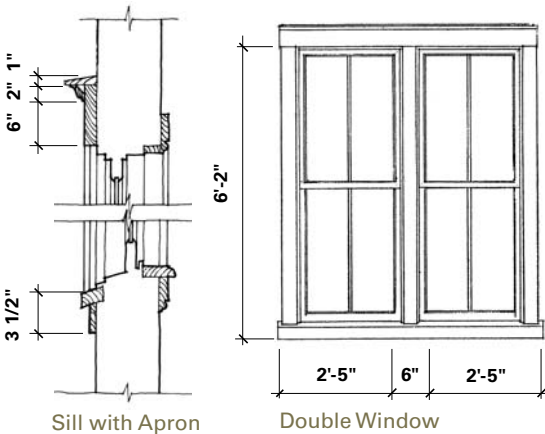

SIMPLE DOORS

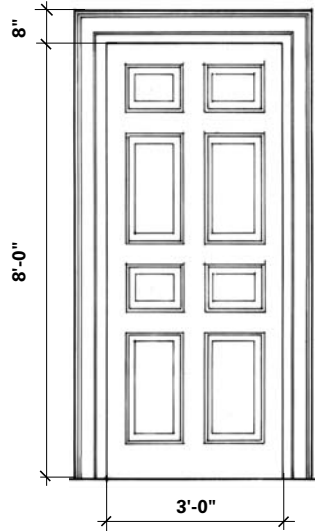
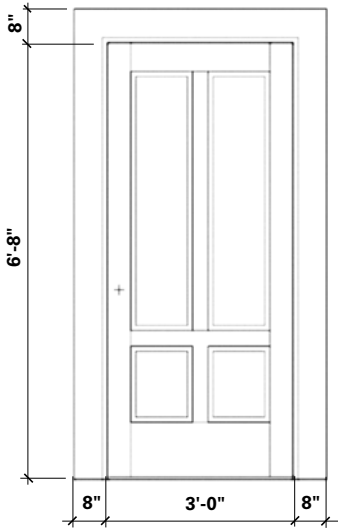

COMMON DOORS

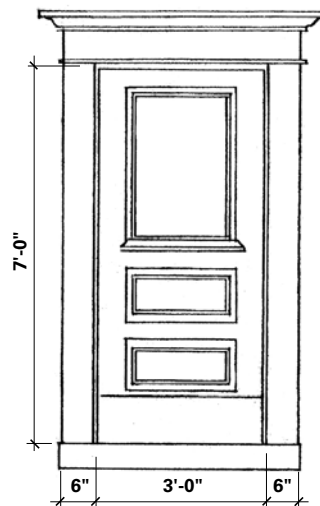
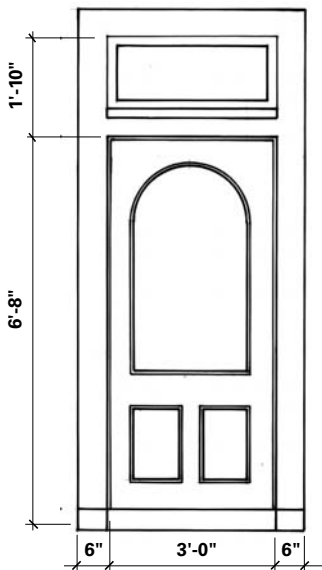

ELABORATE DOORS

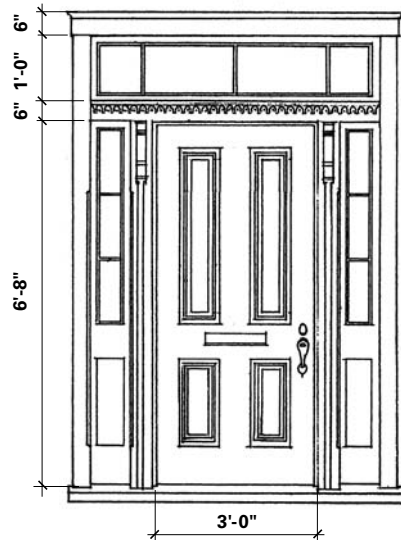
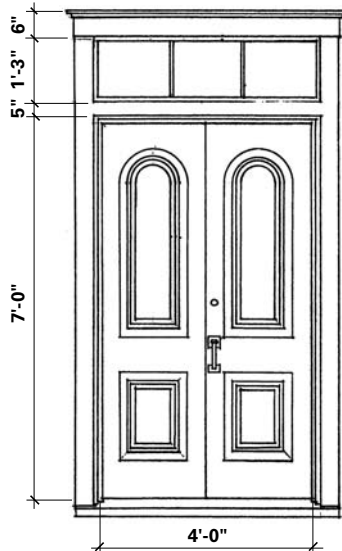

# Porches

## Porch Location and Massing

- >> Full front porches are encouraged.
- >> Porches can be used to wrap the corner of a house, or fill in the void created by an L-shaped plan.
- >> Porches are typically one-story masses.
- >> Minimum recommended porch depth is 6 feet, although 8 feet is preferred.

## Porch Roofs and Eaves

- >> Porches can be one or two stories tall with flat, shed, or shallow hipped roofs (two-story porches are less common).
- >> Full porches may be integrated under the house's main roof.
- >> Shed or hip porches have a 3 in 12 to 4 in 12 pitch. Exposed 2 x 8 rafter tails typically occur every 14 to 16 inches on center.

## Columns and Railings

- >> Column types include 6-inch-square posts and 6- to 8-inch-diameter posts and carved spindles.
- >> First-floor columns are 9- to 10-feet tall, while second-floor columns are 8- to 9-feet tall.
- >> Turned or square balusters are spaced no more than 4 inches apart. Flat-cut ornamental balusters are also used with square columns.
- >> Square pattern lattice is used as infill between piers at the foundation.

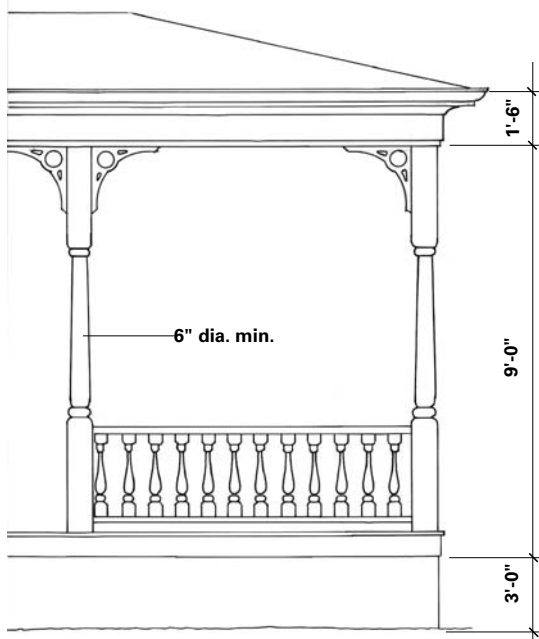

## PORCH LOCATION

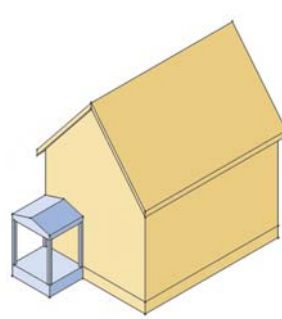

Front gable with single-bay porch at entry

Simple

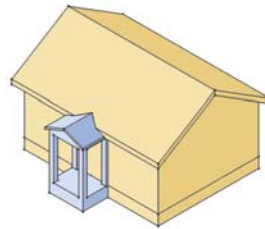

Single-story broad front with single-bay porch at entry centered on street-facing elevation

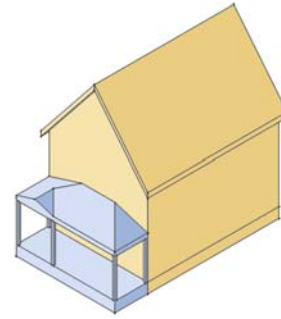

Front gable with full-front hipped-roof porch and gable signifying entry

Common

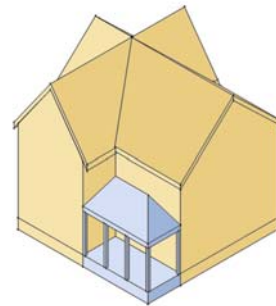

Gable-front L hipped-roof porch at entry

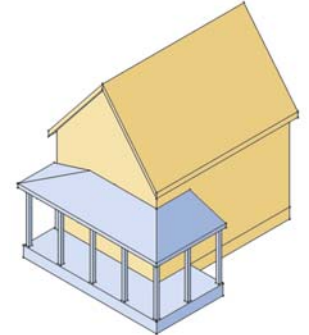

Front gable with full-front hipped-roof porch which returns two bays at corner

Elaborate

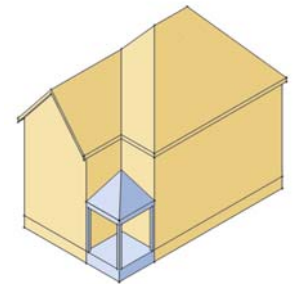

Gable L/Pyramidal with a hipped-roof porch at entry



# Materials and Applications

## PORCH SECTIONS

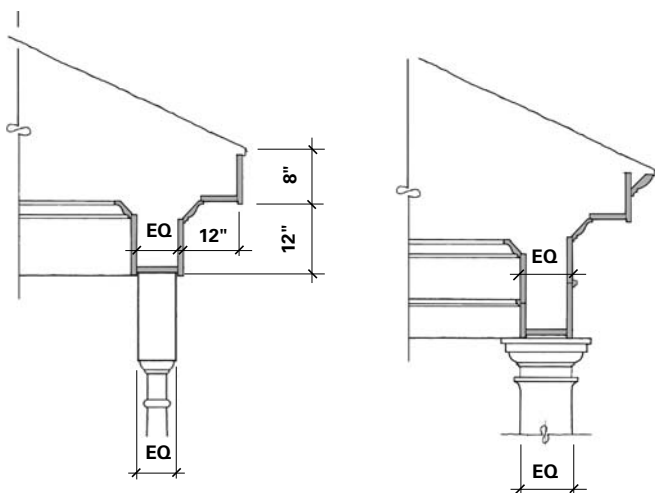

## COLUMN TYPES

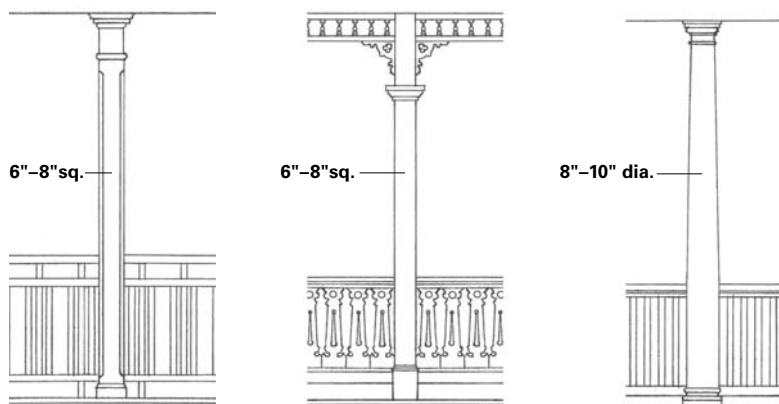

Chamfered Square

Square

Slender Doric

## RAIL DETAILS

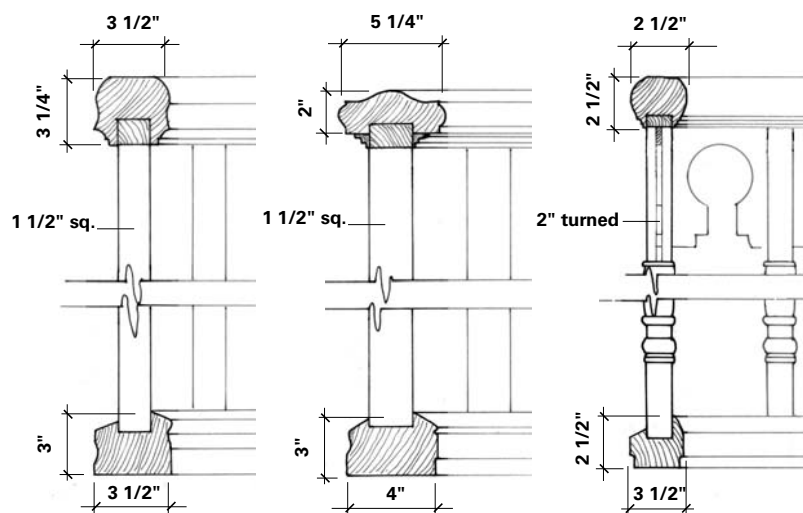

## Roofing

- >> Sawn, laminated asphalt or composition shingles with a slate pattern, or painted metal standing seam or 5-V crimp panels

## Soffits

- >> Smooth-finish composition board, tongue-and-groove wood boards, or fiber-cement panels

## Gutters and Downspouts

- >> Half-round or ogee profile gutters with round or rectangular downspouts in copper, painted, or prefinished metal

## Cladding

- >> Smooth-finish wood or fiber-cement lap siding, 4 to 6 inch exposure
- >> Smooth-finish brick, common bond
- >> Decorative cut wood or fiber-cement shingles in fishscale, diamond, and staggered patterns
- >> Vinyl siding approved by the Vinyl Siding Institute

## Trim

- >> Wood, polyurethane, or composite millwork
- >> Manufacturer's vinyl profiles with integral concealed j-channel, engineered lumber rabbeted or over blocking to conceal the j-channel; exposed j-channel trim is not permitted

## Foundations and Chimneys

- >> Brick veneer, smooth stucco, or cement parging finish

## Windows

- >> Painted wood or composite, or clad wood or vinyl; true divided light or simulated divided light (SDL) sash with traditional exterior muntin profile (7/8 inch wide)

## Doors

- >> Wood, fiberglass or steel with traditional stile-and-rail proportions and raised panel profiles, painted or stained

## Shutters

- >> Wood or composite, sized to match window sash and mounted with hardware to either be or appear to be operable

## Columns

- >> Square box column with chamfered corners in built-up wood, fiberglass or composite material
- >> Turned posts (minimum 6-inch stock) in wood, fiberglass or composite material

## Railings

- >> Milled wood or composite top and bottom rails with square, turned or scroll-cut board balusters

## Porch Ceilings

- >> Plaster, tongue-and-groove wood or composite boards, or beaded-profile plywood

## Front yard Fences

- >> Wood picket or composite material to be rendered indistinguishable from wood, or metal with ornamental posts; low brick walls

## Lighting

- >> Porch pendant, porch fanlight, or wall-mounted lantern



### Essential Elements of the Denton Colonial Revival

- >> Simple, straightforward volumes with side wings and porches added to make more complex shapes
- >> Orderly, symmetrical relationship between windows, doors and building mass
- >> Simplified versions of Classical details and columns, occasionally with Classical orders used at the entry
- >> Multi-pane windows



## DENTON

# COLONIAL REVIVAL



Next to the Victorian, the Colonial Revival is the most prevalent architectural style found in Denton. This version of the style is typical for the Eastern Shore of Maryland and is based upon the Colonial Revival styles that were prevalent throughout the country in the late nineteenth and early twentieth centuries. During this era, elements from Classical and Georgian houses were combined and modified to produce a new vocabulary. This mixing of influences produced a wide variety of expression and form in the Colonial Revival house.

Denton's Colonial Revival houses often have tall, shuttered windows, entry porticos, and the occasional formal cornice treatment. The Colonial Revival style features the formal entry portico in place of the porch that is typically found on other architectural styles. However, to support the connection between the house and the public realm, elaborately paved front walks and formal landscaping are utilized. Formal rules of composition apply to the Denton Colonial Revival, distinguishing it from the Victorian. Windows are rarely paired, but placed on the facade in clear, symmetrical rhythms to reinforce the formality of composition. The Colonial Revival style is stately and remains close to Denton's colonial roots.

ARCHITECTURAL PATTERNS : DENTON COLONIAL REVIVAL



# Massing and Composition

## NARROW FRONT

- >> Front-gable box with roof pitches ranging from 7 in 12 to 12 in 12
- >> Two and three bay compositions are common
- >> Full front porches and side wings are common

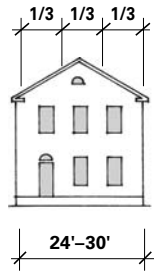
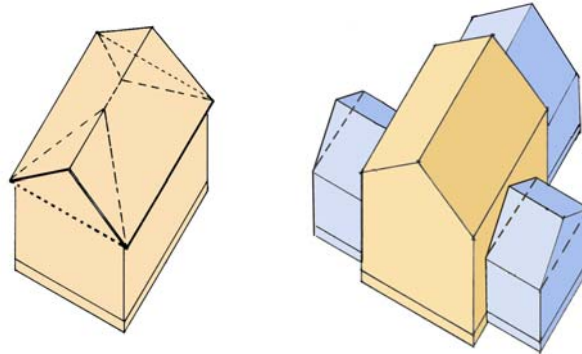

## ONE-STORY BROAD FRONT

- >> Side gable rectangular volume with roof pitches ranging from 7 in 12 to 12 in 12
- >> Symmetrical compositions of doors and windows
- >> Porticos are one-third or one-fifth the length of the main body
- >> Porches, when present, are three-fifths or the entire length of the front facade
- >> One-story side wings often occur

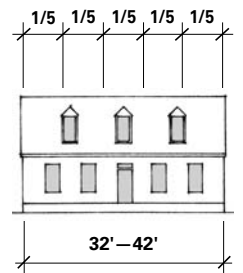
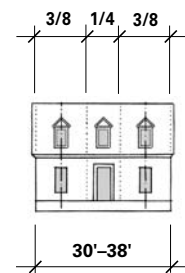
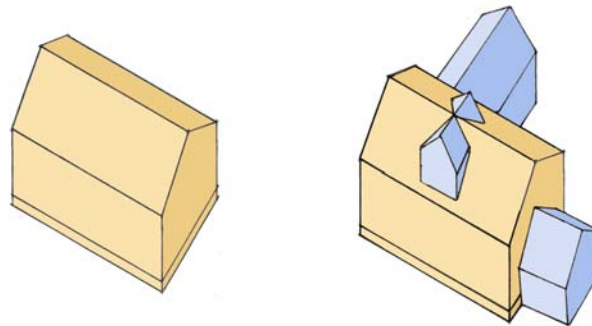

## TWO-STORY BROAD FRONT

- >> Side gable rectangular volume with roof pitches ranging from 7 in 12 to 12 in 12
- >> Symmetrical compositions of doors and windows
- >> Porticos are one-third or one-fifth the length of the main body
- >> Porches, when present, are three-fifths or the entire length of the front facade
- >> One-story side wings often occur

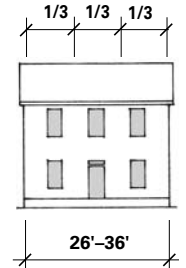
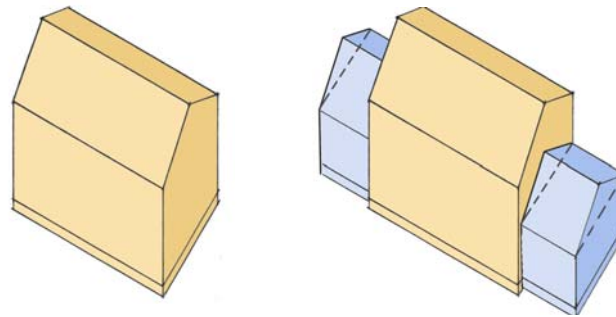

## ONE-AND-ONE-HALF-STORY BROAD FRONT GAMBREL

- >> Rectangular volume with a gambrel roof containing a second story
- >> Symmetrical compositions of doors and windows are most typical, though there are more exceptions with this massing type
- >> Gambrel roofs have two roof pitches, 20 in 12 to 36 in 12 at the eave, and 6 in 12 to 10 in 12 above the pitch break
- >> Shed dormers are common to provide more living space

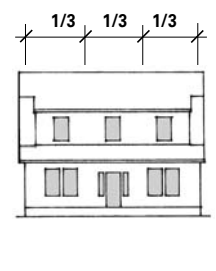
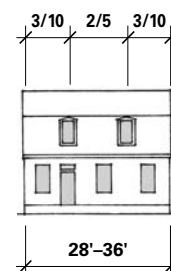
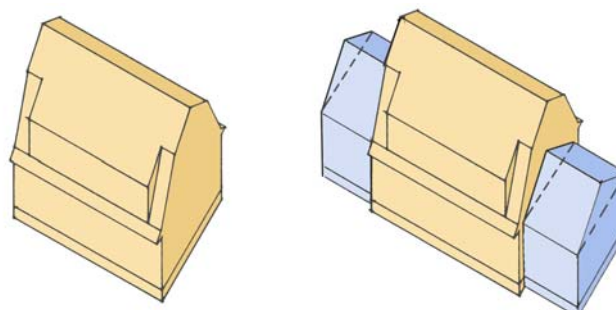

# Typical Wall and Window Sections

## Roof

>> The roof pitch on most houses varies from 7 to 8 in 12.

## Eaves

>> The typical eave types include a simple boxed eave and more formal types with a frieze below the soffit and small profiled molding and dentils.

## Walls

>> For one-story buildings, the minimum floor to ceiling height is 10 feet. For two-story buildings, the minimum floor-to-ceiling height is 10 feet for the first floor and 9 feet for the second floor. Windows head heights should be 8 feet 6 inches for the first floor and 7 feet 6 inches or 8 feet for the second floor for these heights. Corner boards for clapboard siding should be no less than nominal 5/4 by 6 inches.

## Base

>> The first floor of the house is typically set three feet above the finished grade. Houses occasionally have an 8-inch skirt board. When foundation vents are used, they should be centered under first floor windows.

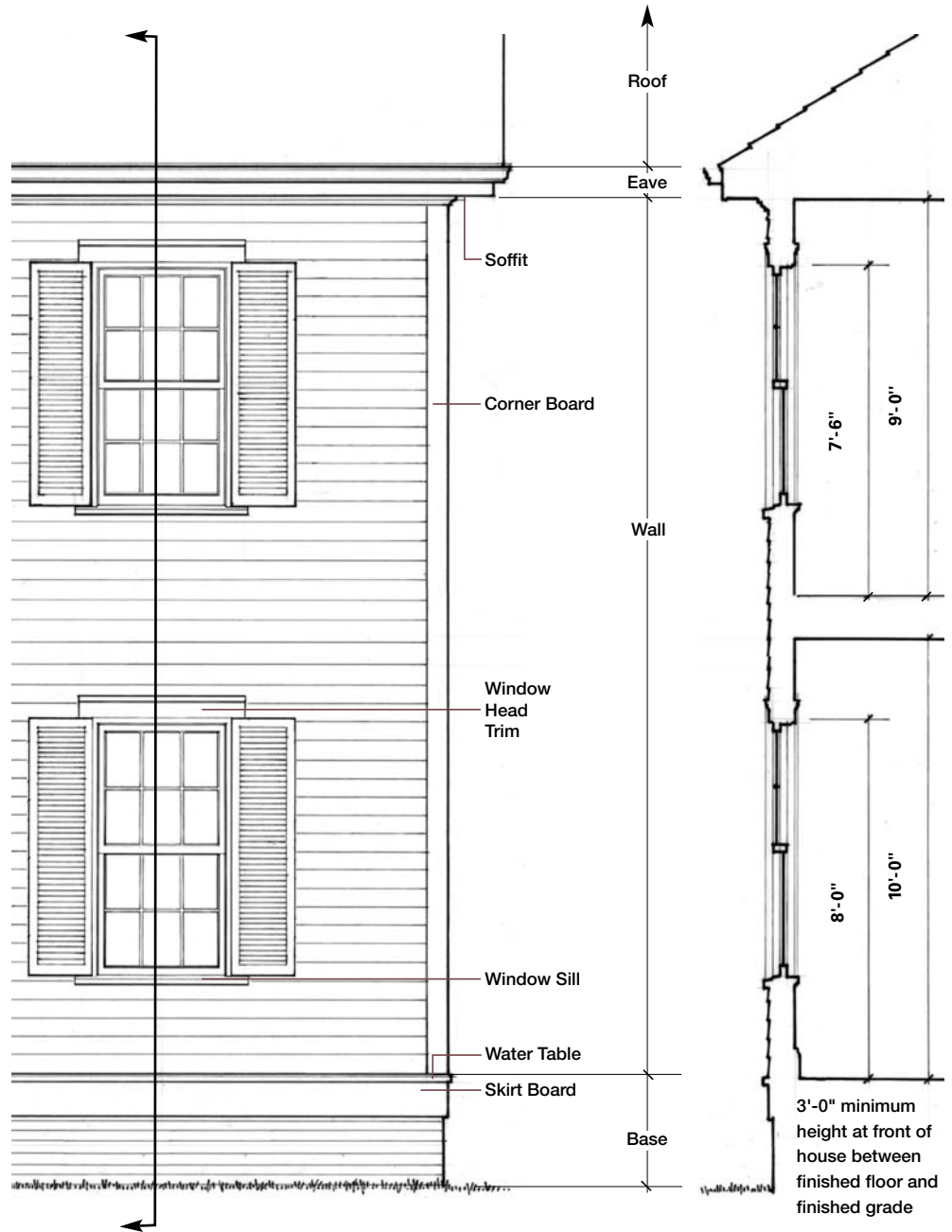

## EAVES

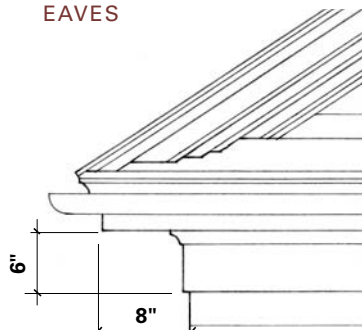

Boxed Eave Detail

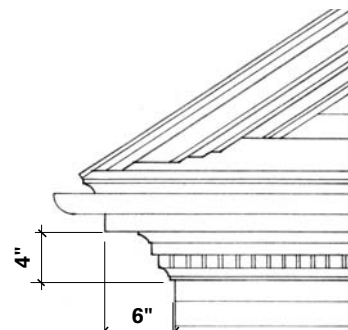

Boxed Eave Detail

# Windows and Doors

## Standard Windows

- >> Windows have vertical proportions.
- >> Muntin patterns are typically 6 over 1, 6 over 6, or 9 over 9 on both floors.
- >> Standard windows are double hung.

## Special Windows

- >> Special windows include angled bay windows, triple windows, and dormers with a pediment.
- >> Bay windows must extend to the ground.
- >> Small rectangular or fan light windows are often used as an accent in gable ends or on the second floor above the entrance.

## Shutters

- >> Operable shutters are encouraged.
- >> If shutters are inoperable, they should be sized and mounted as if operable.

## Doors

- >> Doors typically have six panels.
- >> Door surrounds frequently incorporate sidelights and transoms.

## Trim

- >> Windows and doors typically have a 6-inch-wide flat trim with or without a cap molding, or a 6-inch backband trim.
- >> Brick buildings feature 2-inch brickmold.

### WINDOWS

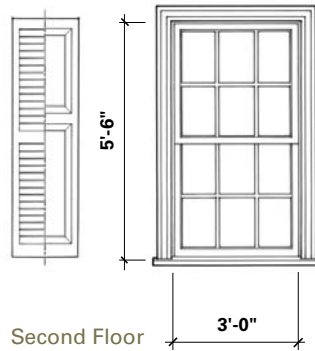

Second Floor

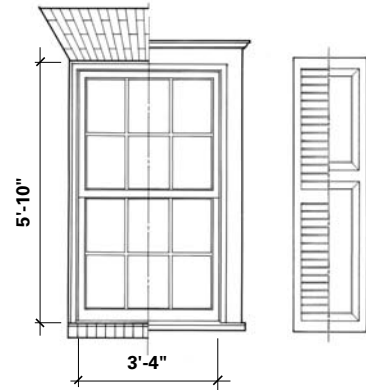

First Floor

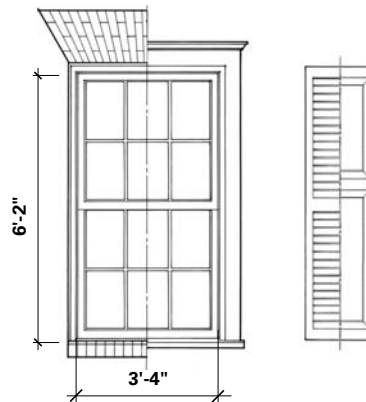
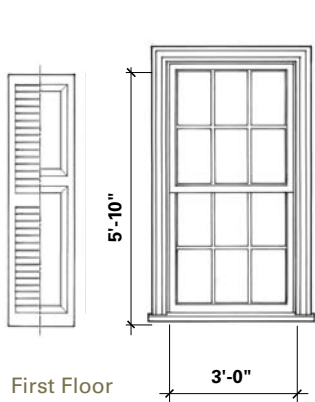

### SPECIAL WINDOWS

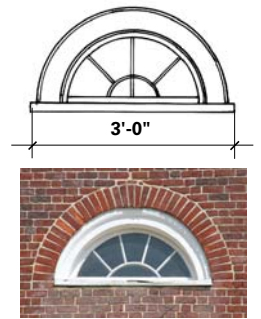
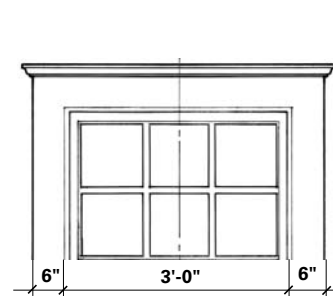
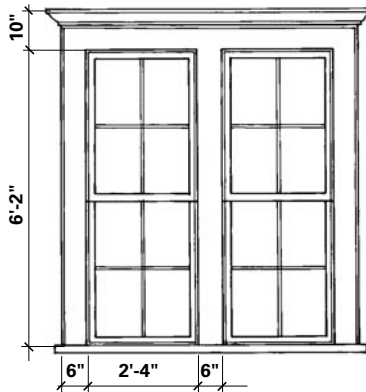

### BAY WINDOW

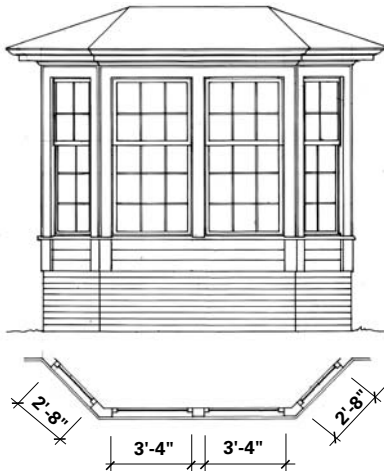

### WINDOW SECTIONS

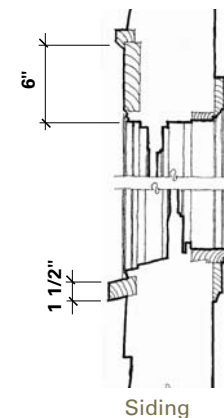

Siding

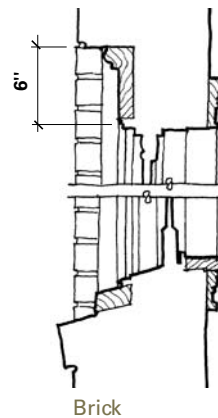

Brick

### DORMER

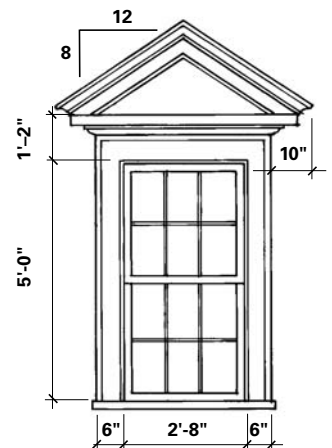

SIMPLE DOORS

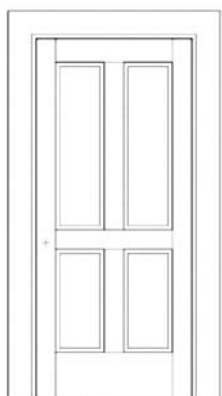
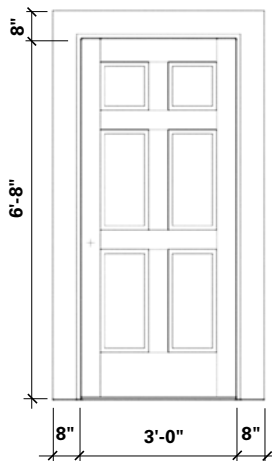

Four-panel alternative



COMMON DOORS

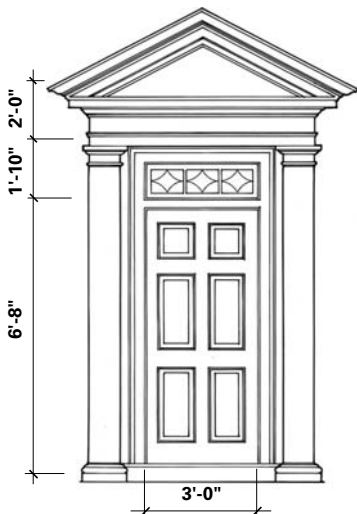
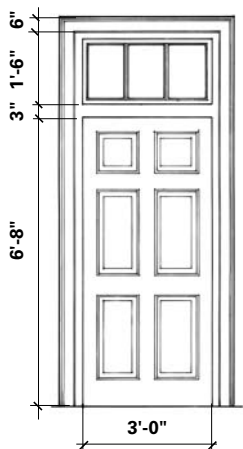

ELABORATE DOOR

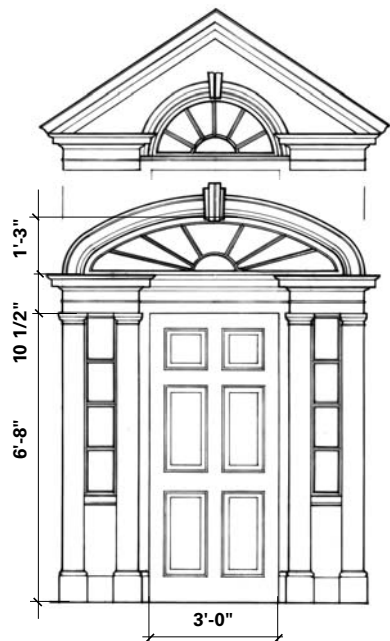
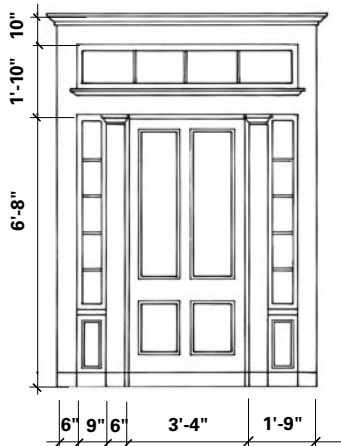

# Porches

## Porch Location and Massing

- >> Porches and porticos should be centered on the composition.
- >> Minimum porch depth is 6 feet, 8 feet is desirable.
- >> For wood deck porches, the gaps between brick piers are infilled with lattice panels. Solid porches should be faced in brick.

## Roofs and Eaves

- >> Porches are one story tall with either flat, shed, or shallow hipped-roofs. Shed or hip porches typically have a 3 in 12 to 4 in 12 pitch.

## Columns and Railings

- >> Columns include 10- and 12-inch round Doric and Ionic columns, pedestal-mounted 8-inch round, and 8- to 10-inch full-height tapered box columns.
- >> Single-story porches have 9- to 10-foot-tall columns, and columns on two-story porches are 9- to 10-foot-tall on the ground floor and 8- to 9-foot-tall on the second floor.
- >> Porch column bays should be more narrow than wide. Balusters should be turned or square, and spaced no more than 4 inches on center.

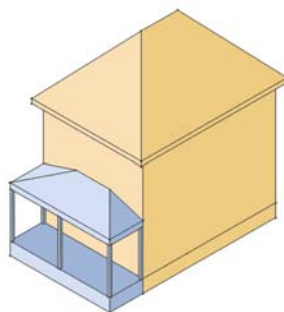

Narrow front hipped roof with full front porch

Simple

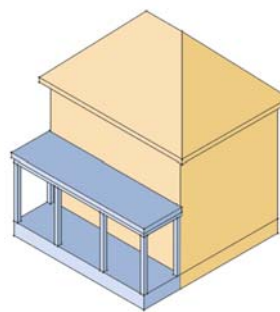

Broad front hipped roof with full front porch

Common

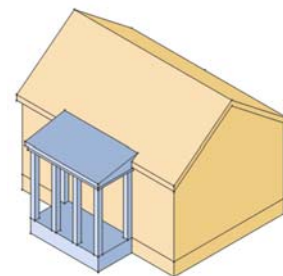

Broad front side gable with add-on porch

Elaborate

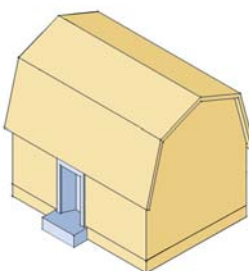

Broad front gambrel with inset entrance porch

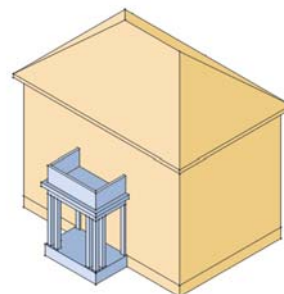

Broad front hipped roof with front entrance porch

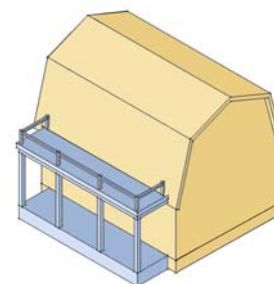

Broad front gambrel with full front porch

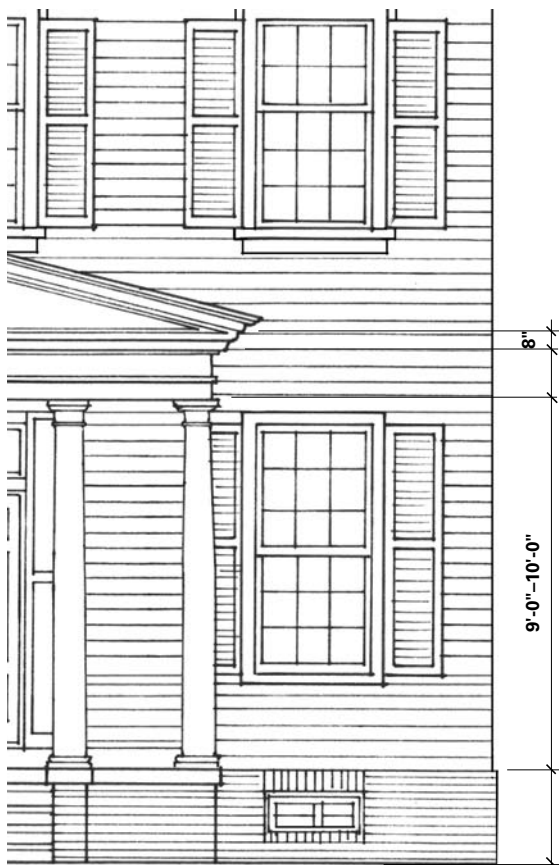
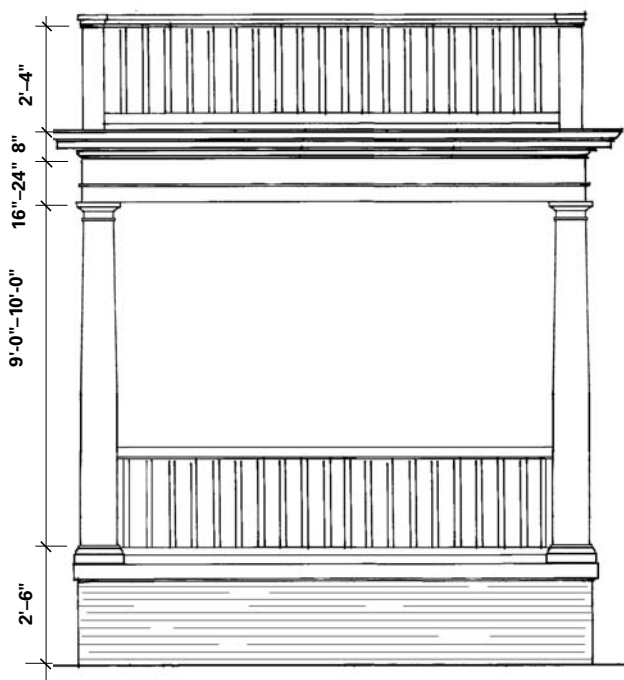

# Materials and Applications

## PORCH SECTIONS

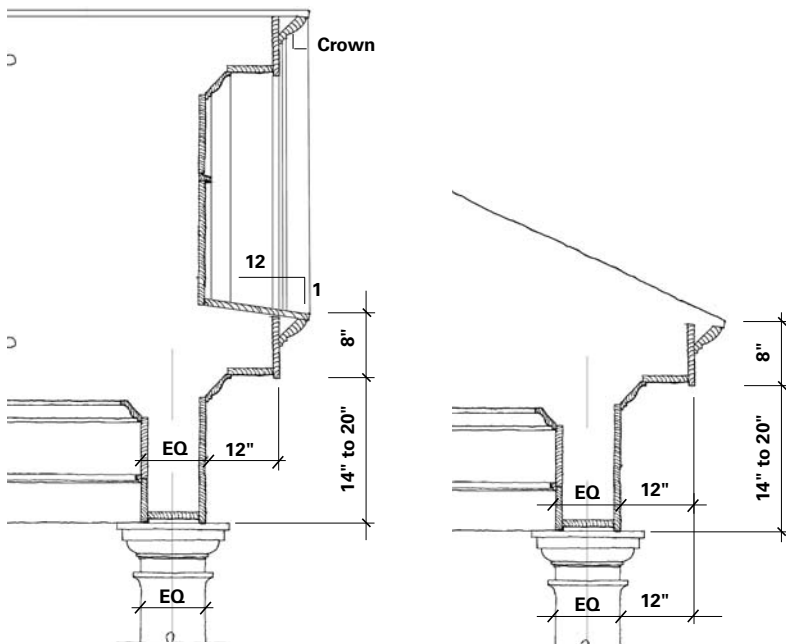

## COLUMN TYPES

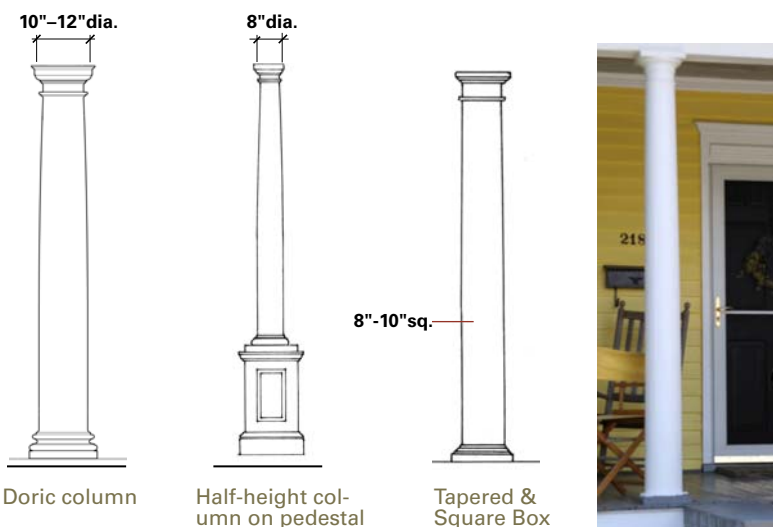

## RAIL DETAILS

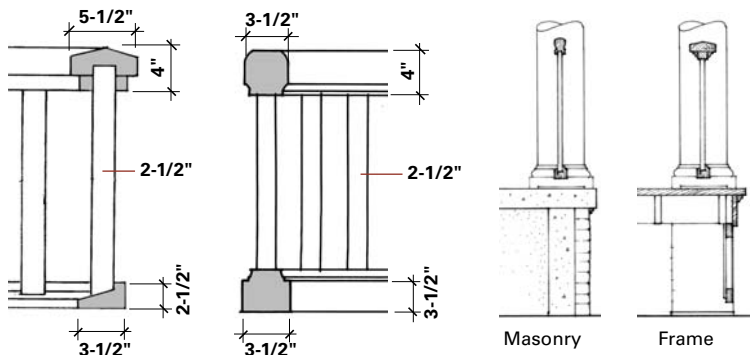

### Roofing

- >> Sawn shingles, laminated asphalt or composition shingles

### Soffits

- >> Composition board with smooth finish, tongue-and-groove wood boards, or fiber-cement panels

### Gutters and Downspouts

- >> Half-round or ogee profile gutters with round or rectangular downspouts in copper, painted or prefinished metal

### Cladding

- >> Smooth-finish wood or fiber-cement lap siding, 6- to 8-inch exposure, or random-width cut shingles
- >> Sand-molded or smooth-finish brick in Common, English or Flemish bond patterns
- >> Vinyl siding approved by the Vinyl Siding Institute.

### Trim

- >> Wood, polyurethane, or composite millwork
- >> Manufacturer's vinyl profiles with integral concealed j-channel, engineered lumber rabbeted or over blocking to conceal the j-channel; exposed j-channel trim is not permitted

### Foundations and Chimneys

- >> Brick veneer, smooth stucco, or cement parging finish

### Windows

- >> Painted wood or composite, or clad wood or vinyl; true divided light or simulated divided light (SDL) sash with traditional exterior muntin profile (7/8 inch wide)

### Doors

- >> Wood, fiberglass, or steel with traditional stile-and-rail proportions and raised panel profiles, painted or stained

### Shutters

- >> Wood or composite, sized to match window sash and mounted with hardware to either be or appear to be operable.

### Columns

- >> Architecturally-correct Classical proportions and details in wood, fiberglass, or composite material
- >> More informal square wooden box columns

### Railings

- >> Milled wood or composite top and bottom rails with square or turned balusters
- >> Wrought iron or solid bar stock square metal picket

### Porch Ceilings

- >> Plaster, tongue-and-groove wood or composite boards, or beaded-profile plywood

### Front Yard Fences

- >> Wood picket or composite material to be rendered indistinguishable from wood, or metal with ornamental posts; low brick walls

### Lighting

- >> Porch pendant, porch fanlight, or wall-mounted lantern



### Essential Elements of the Denton Craftsman

- >> Shallow-pitched roofs with deep overhangs
- >> Deep, broad, horizontal porch elements with expressive structural components
- >> Expressive structural elements such as rafters, brackets, and columns
- >> Predominately crafted with siding
- >> Asymmetrical window and door compositions on two-story houses and symmetry in bungalows

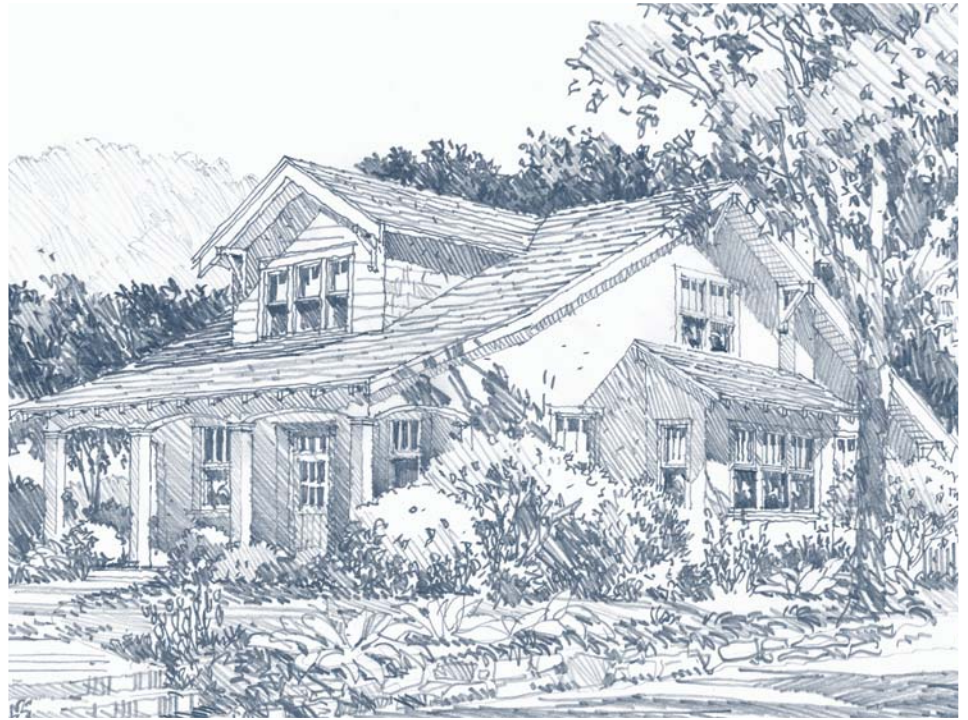

# DENTON CRAFTSMAN



The Denton Craftsman style emerges from two different stylistic movements. First, the two-story examples evolved from Craftsman elements and details applied to largely Victorian two-story houses. These houses are less distinguished in style than the bungalows and cottages, yet they are distinctly Craftsman in their rugged, expressive detailing. The bungalow forms in the one- and one-and-a-half-story houses are often a product of local builders' use of elements from house plan publications and mail order sources. The Arts & Crafts movement espoused a simple decorative expression of structural elements and built-in furniture that builders found suitable for cottage houses. Building during this movement was prolific since bungalows suited well the residential needs of the time.

The Denton Craftsman style is characterized by broad, open porches, roofs with deep overhangs, and exposed rafter tails or decorative brackets; asymmetric compositions, though bungalows are more regular; grouped windows with a variety of upper muntin patterns; expressive trim; and porches with brackets. Columns on Craftsman houses are very diverse in both form and material, and are much less formal than in the other architectural styles represented in this Pattern Book.

ARCHITECTURAL PATTERNS : DENTON CRAFTSMAN



# Massing and Composition

## Narrow Front

- >> Rectangular volume with a 6 in 12 to 8 in 12 roof pitch and gable facing the street
- >> Symmetrically or asymmetrically placed front and/or shed roofed porches are common; either one- or two-story.
- >> An inset one-story porch may also run the full width of the house.

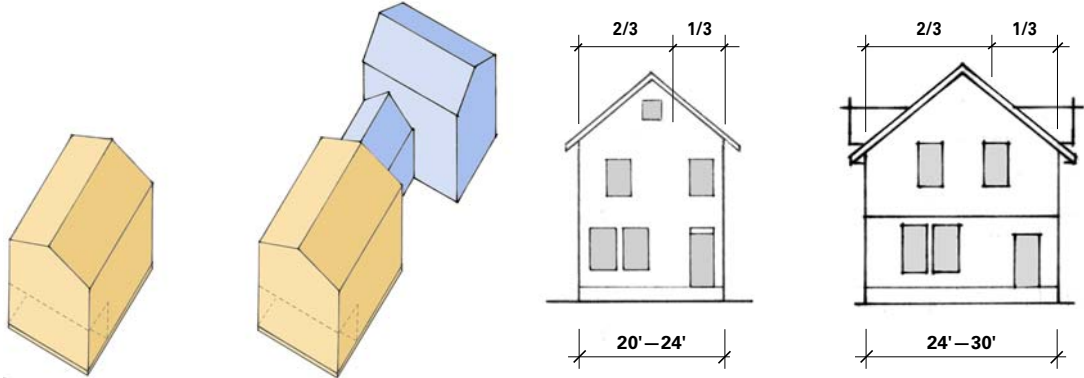

## Hipped

- >> Rectangular or square volume with a 6 in 12 to 8 in 12 roof pitch; the ridge line, if any, runs parallel with the front of the house.
- >> Front gabled and/or shed roofed porches with a 3 in 12 to 5 in 12 pitch are placed symmetrically or asymmetrically on the front facade or as full-facade elements.
- >> Porches are typically one story.

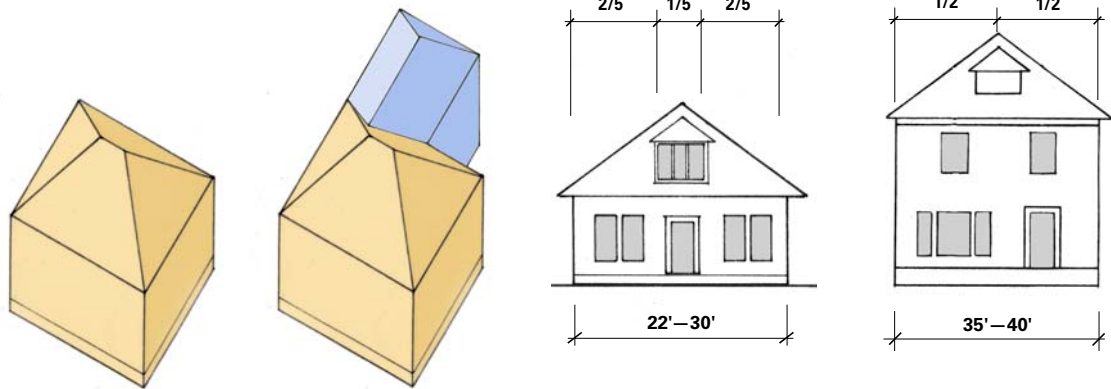

## Broad Front

- >> Rectangular volume with a 6 in 12 to 8 in 12 roof pitch
- >> Asymmetrically placed gabled and/or shed roofed porches are common.
- >> Porches are typically one story.

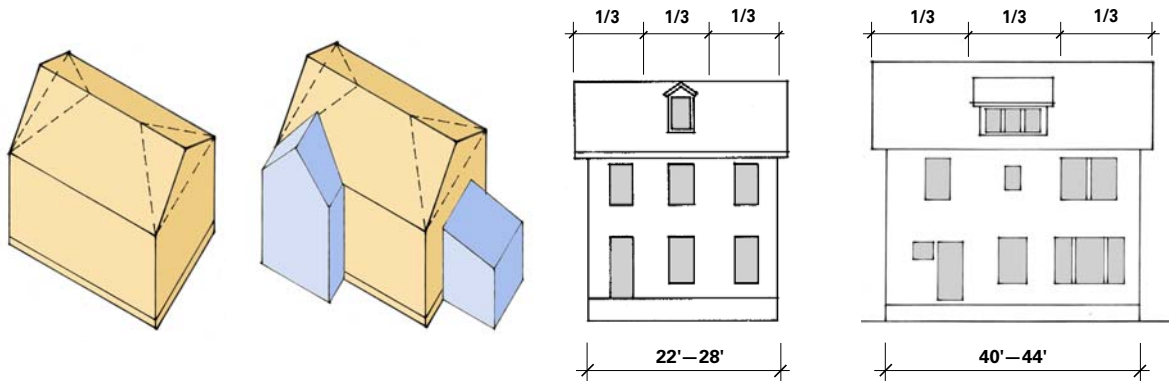

## Broad front/Integral Porch

- >> Rectangular one-and-one-half-story volume with a 6 in 12 to 8 in 12 roof pitch.
- >> The integral porch is set under occupiable interior space, made possible by a dormer and high knee wall on the second floor.
- >> Integral front porches range from half to the full length of the front facade.
- >> Symmetrically placed gabled or shed dormers have a 3 in 12 roof pitch.

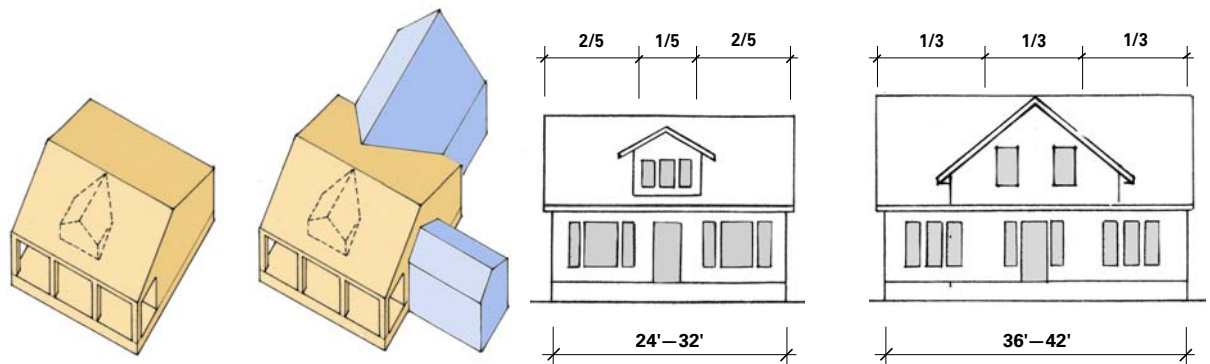

# Typical Wall Sections and Eaves

## ROOFS

>> The roof pitch on most houses varies from 6 to 8 in 12.

## WALL

>> For one-story houses, the minimum floor-to-ceiling height is 9 feet. For two-story houses, the minimum floor-to-ceiling height is 9 feet for the first floor and 8 feet for the second floor. Window head heights should be 8 feet above the floor for first-floor windows and 7 to 8 feet for second-floor windows.

>> Cladding should be consistent on all facades of primary mass. Exceptions include: gables, dormers, and garages.

## EAVES

>> Deep eaves are a dominant characteristic.

>> Open eaves typically have a 2 x 6 or 2 x 8 shaped rafter tail 16 to 24 inches on center. Gables feature deeper rake boards.

>> Boxed eaves often have profiled outriggers or brackets at 24 inches on center.

>> Frieze board, if used, is 8 to 12 inch either touching/co-planar with, or no more than 8 inches above the window head trim.

## BASE

>> The first floor is typically set three feet above the finished grade. Wood clad houses have 8 to 10 inch wide skirt boards. When window wells are used, center under windows.

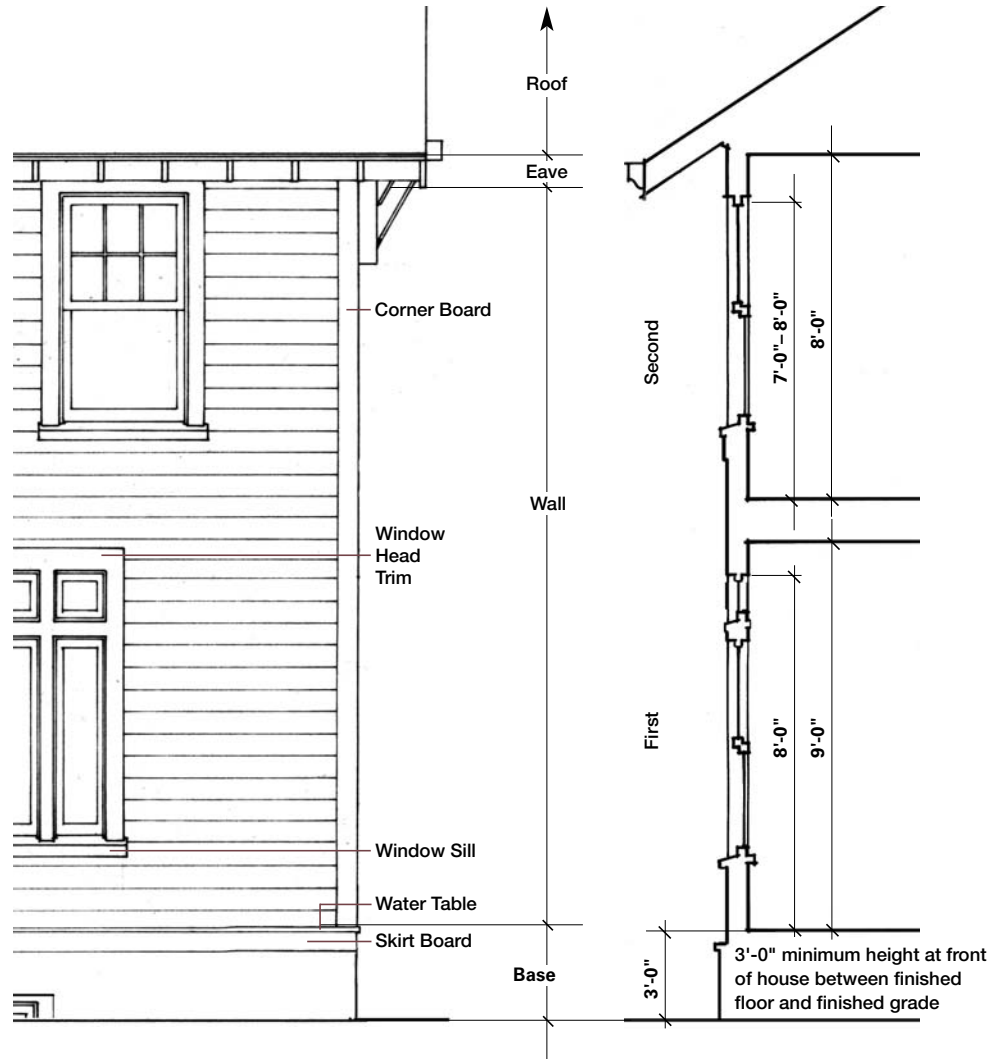

## EAVE ELEVATIONS

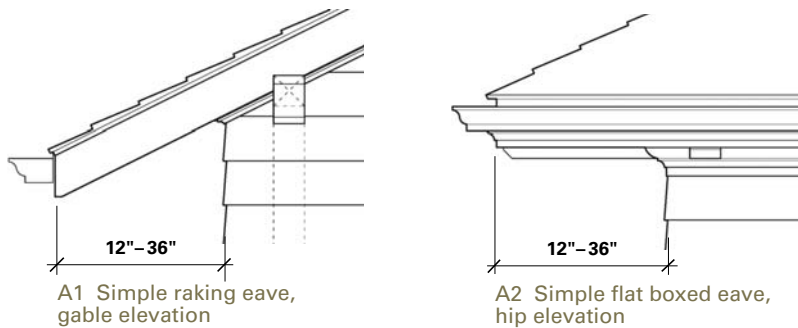

## EAVE SECTIONS

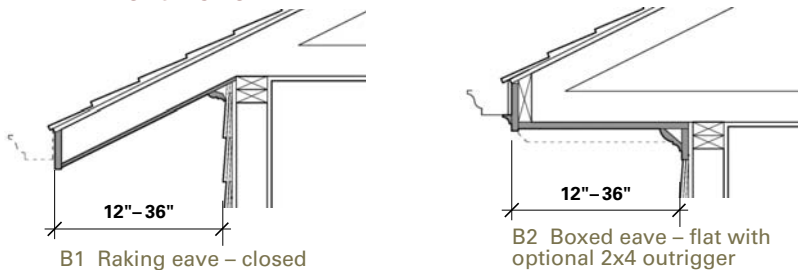

# Windows and Doors

## STANDARD WINDOWS

- >> Windows are typically vertical in proportion and have a 3 over 1, 6 over 1, or 9 over 1 muntin pattern.
- >> Standard windows are double hung.

## SPECIAL WINDOWS

- >> Special windows include paired or triple windows, small square accent windows, and box bay windows supported on wood brackets.
- >> Broad, horizontal windows divided into several vertical panes occur in dormers and gables. Other dormer windows are ganged together in wide gabled or shed dormers.

## DOORS

- >> Doors are often stained wood with either wood plank design or a panel door with the top half glazed.
- >> Doors may have sidelights or transoms

## TRIM

- >> Windows and doors have 6-inch straight or tapered flat trim.
- >> Window and door trim carries a simple molding and cap above.

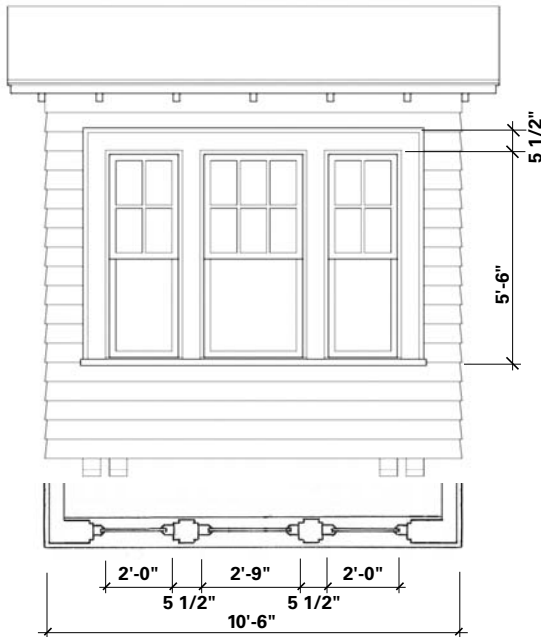

## WINDOWS

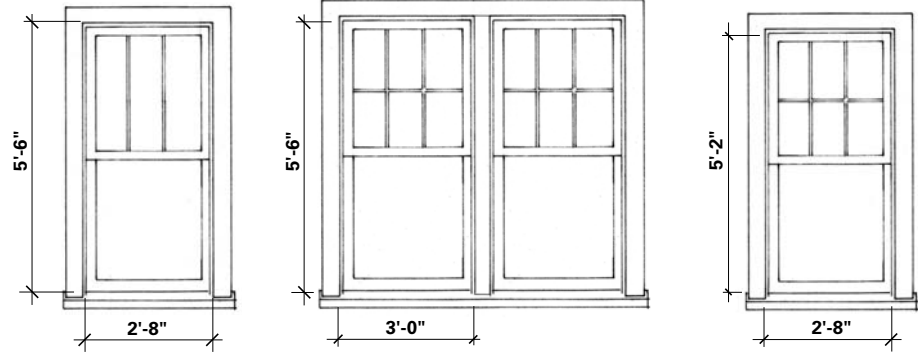

## Second Floor

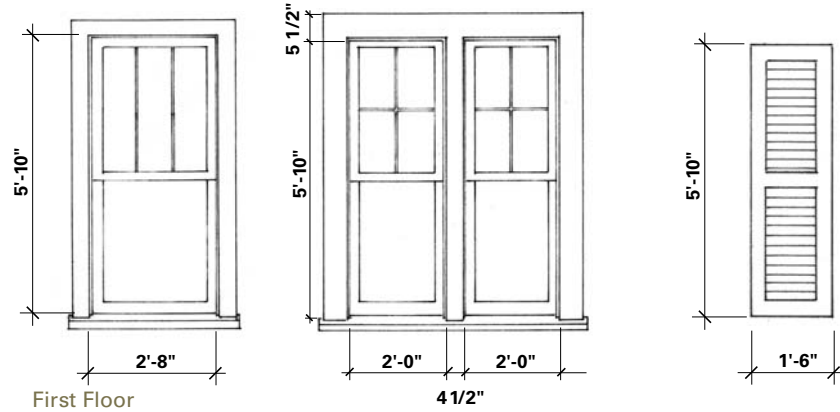

## First Floor

## SPECIAL WINDOWS

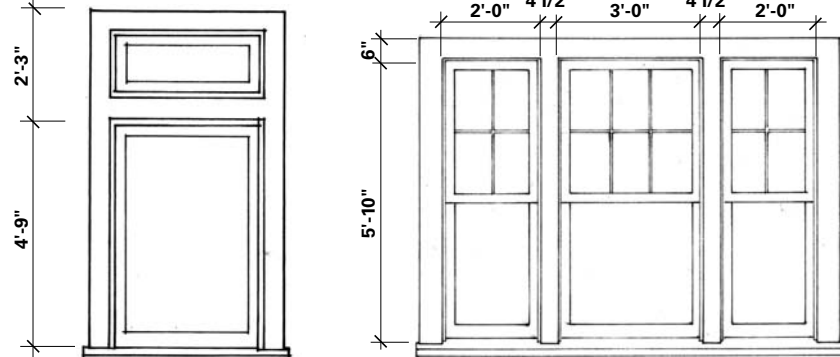

## TYPICAL WINDOW DETAIL

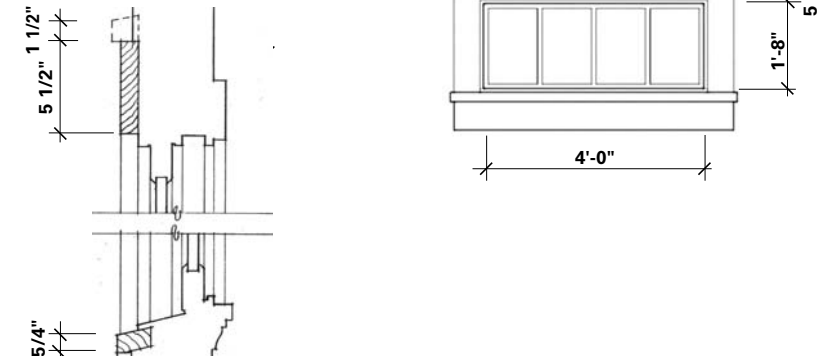

SIMPLE DOORS

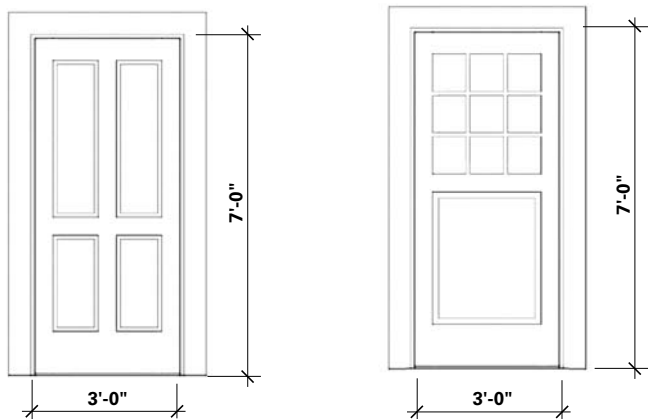

COMMON DOORS

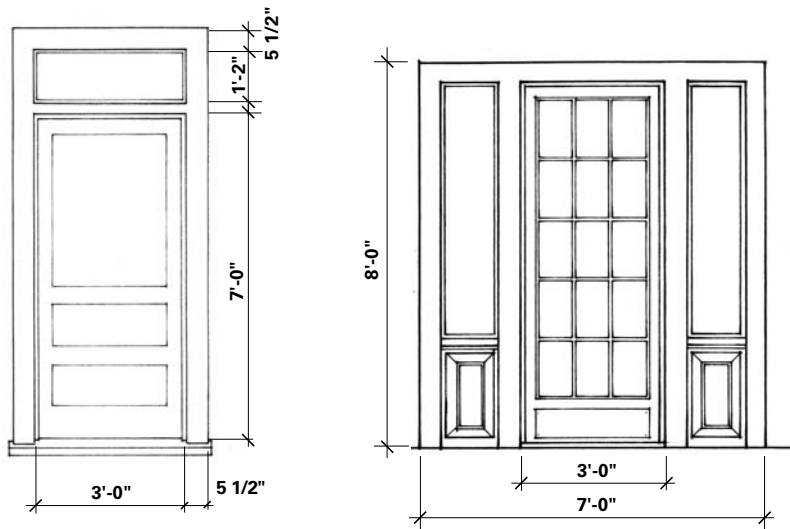

ELABORATE DOORS

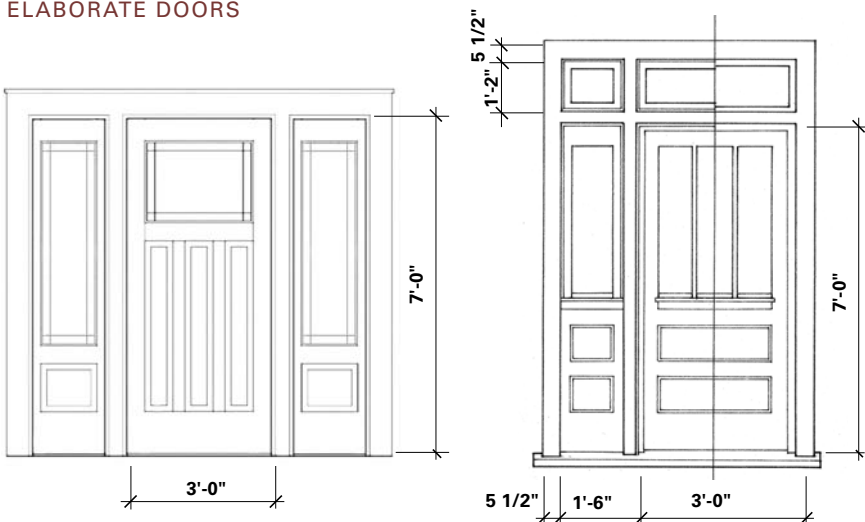

# Porches

## PORCH LOCATION AND MASSING

- >> Porches are broad and low when present, and can wrap the house or fill in the void created by an L-shaped house plan.
- >> Full front porches are encouraged. Minimum porch depth is 6 feet, but 8 feet is recommended.
- >> For wood deck porches, the gaps between brick piers are infilled with lattice panels. Solid porches should be faced in brick.

## COLUMNS AND RAILINGS

- >> Bungalows have Classically-styled columns set on square piers or solid porch balustrades. These porches are usually matched with bracketed box eaves.
- >> Columns include full-height tapered box, half-height paneled box, and three-quarter-height paired box columns.

## PORCH ROOFS AND EAVES

- >> Porches can have gable-ends, shed roofs or combinations of the two forms.
- >> Gable-end porches are designed to express structural elements. Shed and hip porches typically have a 3 in 12 to 4 in 12 pitch.
- >> Porches have deep eaves often repeating the same rafter or eave treatment as the main house body.
- >> Exposed rafter tails are either shaped or cut plumb.

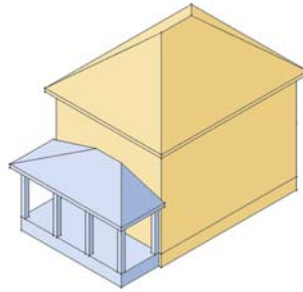

Hipped roof double-story, with full front hipped porch

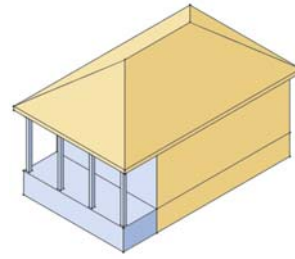

Hipped roof single-story, with full front inset porch

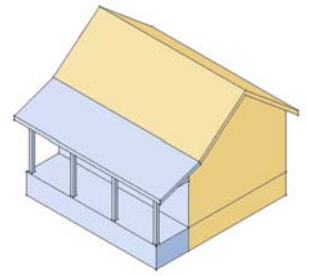

Side gable double-story, full front entry porch of shallower roof pitch

Simple

Common

Elaborate

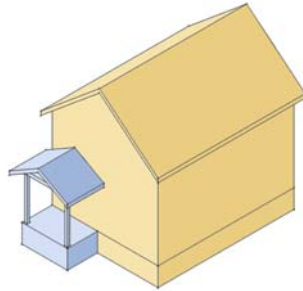

Front gable two-story, with single-bay porch at entry

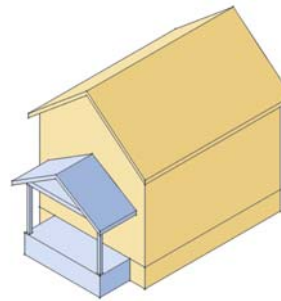

Front gable double-story, with centered two-bay porch at entry

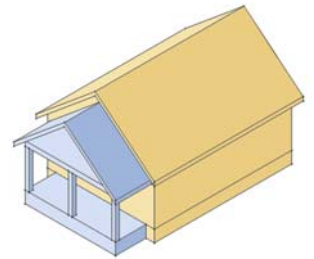

Front gable single-story, with nested gable full front porch

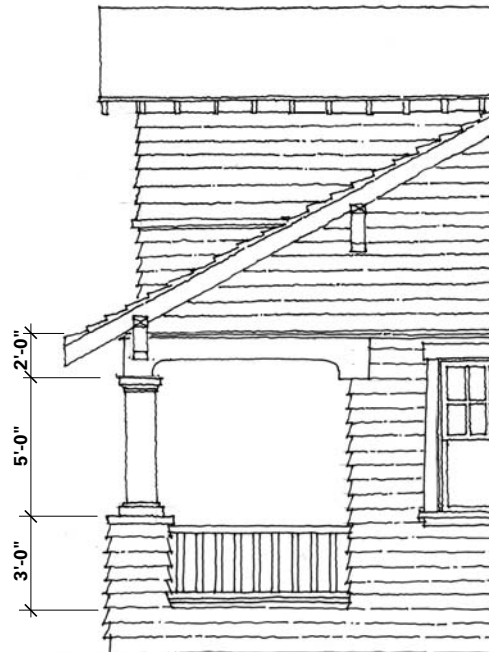

# Materials and Applications

## PORCH SECTIONS

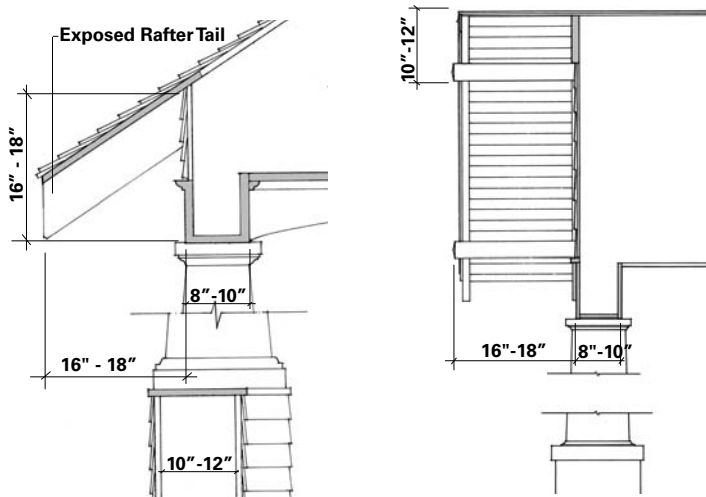

## COLUMN TYPES

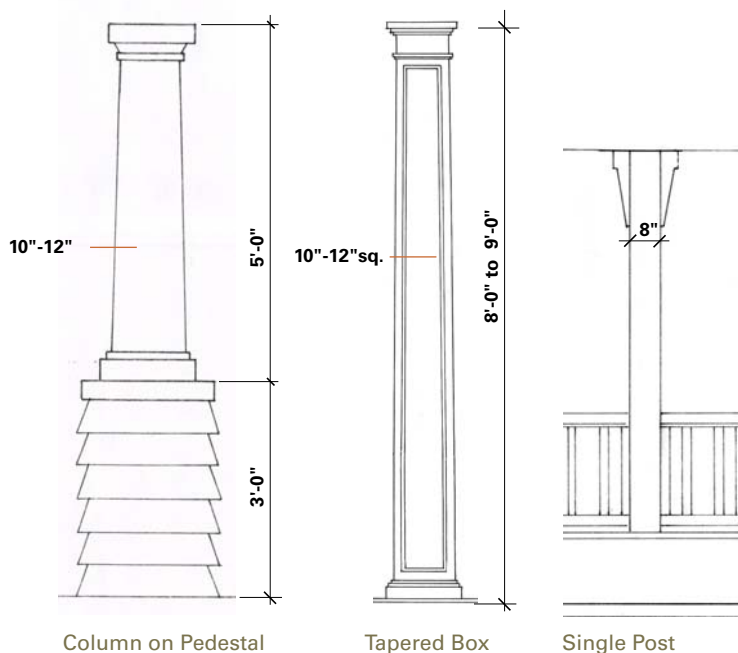

## RAIL DETAILS

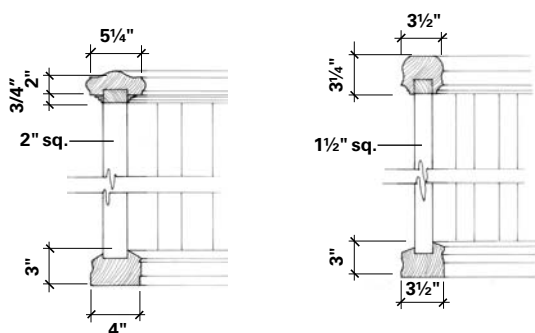

## Roofing

- >> Cedar shakes, sawn shingles, laminated asphalt or composition shingles

## Soffits

- >> Composition board with smooth finish, tongue-and-groove wood boards, or fiber-cement panels

## Gutters and Downspouts

- >> Half-round or ogee profile gutters with round or rectangular down spouts in copper, painted or prefinished metal

## Cladding

- >> Smooth-finish wood or fiber-cement lap siding, 4 to 8 inches exposure, with mitered corners or 5/4 x 6-inch corner board trim
- >> Random-width cut wood or fiber-cement shingles with mitered corners or 5/4 x 6-inch corner board trim
- >> Smooth-finish brick in common bond pattern
- >> Vinyl siding as approved by the Vinyl Siding Institute

## Foundations, Piers and Chimneys

- >> Brick veneer, smooth stucco, or cement parging finish

## Trim

- >> Wood, polyurethane, or composite millwork
- >> Manufacturer's vinyl profiles with integral concealed j-channel, engineered lumber rabbeted or over blocking to conceal the j-channel; exposed j-channel trim is not permitted

## Shutters

- >> Wood or composite, sized to match window sash and mounted with hardware to either be or appear to be operable.

## Windows

- >> Painted wood or composite, or clad wood or vinyl; true divided light or simulated divided light (SDL) sash with traditional exterior muntin profile (7/8 inch wide)

## Doors

- >> Wood, fiberglass or steel with traditional stile-and-rail proportions and panel profiles, painted or stained

## Columns

- >> Wood, fiberglass, or composite material

## Railings

- >> Wood or composite top and bottom rails with square balusters
- >> Solid rails clad in siding, shingles, brick or stone veneer

## Brackets

- >> Wood or fibercement

## Porch Ceilings

- >> Plaster, tongue-and-groove wood or composite boards, or beaded-profile plywood

## Front Yard Fences

- >> Wood picket or composite material to be rendered indistinguishable from wood, or metal with ornamental posts; low brick walls

## Lighting

- >> Porch pendant, porch fanlight, or wall-mounted lantern



# Materials and Methods (For All Styles)

## Material Usage

The use and placement of materials are very important in constructing a house of lasting value that fits in with its environment. Because of its durability, brick is an important building material. Three options are shown for brick placement, all of which respect the historic usage patterns of brick as well as prevent poor detailing in transitioning between brick and other facade materials.

## Window and Door Placement

Windows and doors should be placed to provide natural light to all rooms in a house. Do not neglect the side facades, where windows and doors can be used to animate those building faces as well as provide as much natural light as possible to the interior of the house. Side windows are particularly important on houses on corners and those that wrap along curving streets and spaces.

## Main Body Massing

The desire for large houses often results in houses that look oversized for their lots. A common problem, this issue can be dealt with by maintaining a main body size or mass that is no larger than 44 feet wide. In studies of historic houses in Denton and across the United States, wings and additions that are of a different scale are used to add floor area, not an extrusion of the main body of the house. Wings should be set back from the main body facade a minimum of 4 feet to provide visual definition. If a wing is a garage, it should be set back at least 8 feet to hide the parking of an adjacent automobile.

### MATERIALS: USE OF BRICK

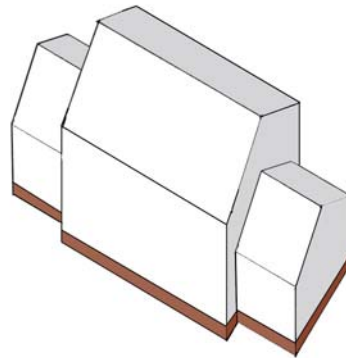

1 Wrap the entire foundation of the house with brick.

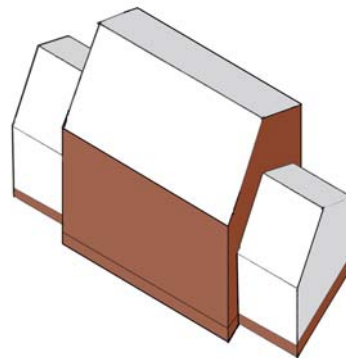

2 Use brick on the entire foundation and all sides of the main body, with wings of other materials.

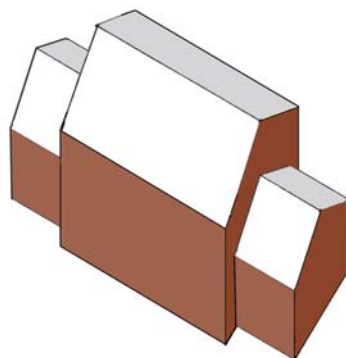

3 Use brick on all sides of the main body and wings.

### WINDOW AND DOOR PLACEMENT

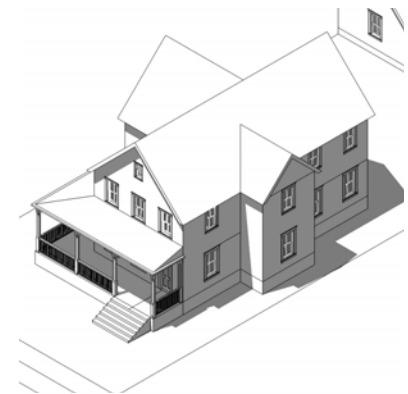

Houses need windows on all sides. Windows must occur on the side of the main body and wings.

### SCALE OF HOUSE AND WINGS

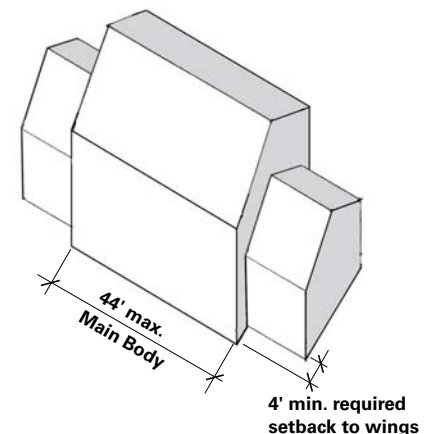

# Architectural Resources

The following partial list of national manufacturers of building products, developed by Urban Design Associates, provides a starting point for home owners searching for appropriate home improvement materials. These products have been selected due to their appropriateness for the architectural styles outlined in the Pattern Book.

## Windows

**Marvin** (<http://www.marvin.com>)

- >> Wood double-hung and casement
- >> Clad double-hung and casement with aluminum trim accessories
- >> Replacement sash with profiled aluminum panning
- >> Wood or clad simulated divided lights (SDL)
- >> French doors

**Caradco**

(<http://www.jeld-wen.com/windows/wood/caradco>)

- >> Wood double-hung and casement
- >> Clad double-hung and casement with aluminum trim accessories
- >> Wood or clad simulated divided lights (SDL)
- >> French doors

**Windsor** (<http://www.windsorwindows.com>)

- >> Wood double-hung and casement
- >> Cellular PVC Legend Series double-hung and casement
- >> Wood or PVC simulated divided light (SDL)
- >> Direct set transoms and sidelights

## Entry Doors

**Simpson** (<http://www.simpsondoor.com>)

- >> Wood doors: Appropriate for all styles; hard to find Arts & Crafts door (#1662) is less than \$400; several hard-to-find 2-over-3-light Victorian doors; European Romantic doors

**Nord** (<http://jeld-wen.com/windows/wood/norco>)

- >> Wood doors: Classical and Colonial Revival styles, some Victorian and European Romantic doors

**ThermaTru** (<http://www.thermatru.com>)

- >> Fiberglass and Premium Steel Series
- >> Steel Doors: Classical, Colonial Revival and Victorian styles; acceptable European Romantic and Arts & Crafts doors

**Stanley** (<http://www.stanleyworks.com>)

- >> Fiberglass and steel doors: Classical, Colonial Revival and Victorian styles; acceptable European Romantic doors

**Peachtree** (<http://www.peach99.com>)

- >> Fiberglass and steel doors: Classical, Colonial Revival and Victorian styles; acceptable European Romantic doors

## Screen and Storm Doors

**Paul Argoe Screens, Inc.**

**J&L Shutters** (<http://www.jlshutters.com>)

- >> Stephen Fuller Signature Series (composite shutters, Permex)

## Columns

**Turncraft** (<http://www.turncraft.com>)

- >> Architecturally correct round and square composite and wood columns; Arts & Crafts tapered square *Polybox*; composite columns

**Column and Post** (<http://www.columnpost.com>)

- >> Architecturally correct round and square composite columns

**Somerset** (<http://www.somersetcolumns.com>)

- >> Architecturally correct round and square wood columns and pilasters

**HB&G** (<http://www.hbgcolumns.com>)

- >> PermaPorch system: Cellular pvc; 2x2 square or turned balusters with 'Savannah' top rail

## Shutters

**Southern Shutter Company**

(<http://www.southernshutter.com>)

**Paul Argoe Screens, Inc.**

## Exterior Siding (synthetic options)

**James Hardie** (<http://www.jameshardie.com>)

- >> Hardiplank (fiber cement) lap siding, shingle, panel, and soffit products

**Georgia-Pacific** (<http://www.gp.com>)

- >> Fiber cement cladding board

**Vinyl Siding Institute** (<http://www.vinylsiding.org>)

- >> Approved vinyl siding

## Exterior Molding, Trim and Brackets (synthetic options)

**Chemcrest** (<http://www.chemcrest.com>)

- >> Classic Moulding and Door: Crown, bed, casing, and brackets in polyurethane

**Azek** (<http://www.azek.com>)

- >> Cellular PVC flat sheet (4 x 8, 4 x 10 and 4 x 12 feet) for gables, soffits, etc. 3/4"-thick trim boards, 5/4"-thick trim boards (4" and 6" widths), tongue-and-groove paneling

**Royal Wood** (<http://www.royalwood.com>)

- >> Composite 1x trim boards, brickmold and T&G paneling for porch ceilings

**Fypon or Duraflex** (<http://www.fypon.com>)

## Porch Ceilings

**Georgia-Pacific** (<http://www.gp.com>)

- >> *PlyBead Classic* or T&G beaded paneling

## Fencing (synthetic options)

**Kroy** (<http://www.kroybp.com>)

- >> Classic Manor Collection: Vinyl fences in traditional designs and profiles

## Garage Doors

**Designer Door** (<http://www.designerdoors.com>)

**Clopay Doors** (<http://www.clopay.com>)

## Roof Shingles and Tiles (synthetic options)

**Majestic Skylines** (<http://www.majesticskylines.com>)

- >> Synthetic slate

**Owens Corning** (<http://www.miravistarroof.com>)

- >> MiraVista specialty roofing: synthetic shakes, slate, copper, and metal
- >> Berkshire Collection: composite shingles

## SECTION F

# GREEN BUILDING GUIDELINES

Whether the term used is green building, sustainable design, or high performance buildings, all refer to the planning, design, construction, and maintenance of buildings that are energy-efficient, healthy, and environmentally friendly. The Denton Pattern Book presents an unprecedented opportunity to help developers and home owners incorporate green building strategies and systems into existing houses, infill and redevelopment, as well as new construction.

Although traditional and older architecture in Denton uses climatically responsive design strategies that enhance human comfort without the use of electricity such as porches, tall ceilings, large windows, and roof overhangs, newer houses generally have relied almost exclusively on fossil-fuel-dependent mechanical systems for heating and cooling. Whether the energy source is electricity, gas, oil, wind, or solar, increasing the efficiency of a house reduces energy bills and lessens the negative effect on the environment. Using 30% less energy translates directly into financial savings. Moreover, the small increase in up-front construction costs attributable to energy efficiency measures will be returned in longer-term savings to the home owner or renter. Green building strategies are important, therefore, not only because of their environmental and human benefits, but for the cost savings and increased affordability they provide.

A systems approach is essential to successful green building and every well-designed, energy-efficient building incorporates an interrelated roster of active and passive elements that control, move, circulate, or retain energy, air, and water to achieve human comfort, functionality, and safety. For example, climate and solar orientation should be factored into decisions about the location and number of windows. Insulation choices, tightness of the building envelope, and foundation choices all contribute to the size of the heating-ventilation-air conditioning (HVAC) system. Buildings that are designed to interrelate these elements achieve greater energy efficiency, comfort, safety, and affordability for their owners and occupants.

## Strategies

### Active Energy-Efficient Strategies

Energy-efficient houses provide significant benefits including reductions in energy demand, utility costs, and pollution, as well as enhanced human comfort, health, durability, quality, and control. One way to achieve energy efficiency in new construction is to follow the Energy Star Program, a national, voluntary program sponsored by the U.S. Environmental Protection Agency (EPA) to reduce greenhouse gas emissions and protect the environment. Energy Star houses are 15-30% more energy efficient than houses built to national or state energy codes. Program requirements are typically met through a combination of building-envelope upgrades, high-performance windows, controlled air infiltration, upgraded heating and air conditioning systems, and tight duct systems. These features contribute to improved house quality and home owner comfort, lower energy demand, lower utility bills, and reduced air pollution. The program is clear and easy to use, affordable, and is monitored to ensure high quality and efficient construction.

#### MECHANICAL HEATING, COOLING, AND DEHUMIDIFICATION

To achieve the highest energy efficiency, mechanical units must be sized properly for a given house or building. Under- or oversized systems do not achieve the desired balance of heating, cooling, and dehumidification for human comfort. The hot, humid climate along the Eastern Shore for more than half the year necessitates a high-efficiency, central air-conditioning unit to provide comfort, significant energy reductions, and substantial cost savings. An optional, dedicated, whole-house dehumidifier will help to further control indoor humidity and increase comfort.

#### APPLIANCES AND LIGHTING

Appliances and lighting account for 40% of home energy usage with refrigerators typically being the single biggest energy-consuming home appliance. Energy Star appliances meet specific energy criteria set by the EPA and use an average of 10-15% less energy than non-certified products, thereby reducing energy costs and pollution.

#### WATER HEATERS

Water heating is typically the second largest household energy expense. Greater efficiency can be achieved simply and affordably by using less hot water, setting the heater temperature at 115°F, and wrapping the heater and pipes with insulation. Tankless (on-demand) hot water heaters typically cost less and are more efficient because they do not store hot water if there is no demand. Solar hot water heaters use the sun to heat water or a heat-transfer fluid in collectors, reducing the need for conventional water heating by about two-thirds.

### Passive Design Strategies

Passive design strategies refer to non-mechanical systems or architectural features that use the sun's natural energy to heat living spaces during the colder seasons and minimize heat gain in the warmer ones. Solar energy is a renewable, non-polluting natural energy source. Passive design features do not generate greenhouse gases, deplete fossil fuels, or rely upon costly, and at times unreliable, energy sources. The architectural features described on the next two pages are all examples of effective passive design elements suitable for use in all the traditional Denton architectural styles. Passive systems should be considered early in the design process, and used in conjunction with a well-built, well-insulated house that has an efficient mechanical HVAC system.

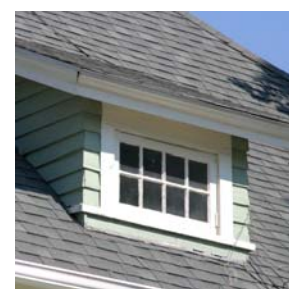
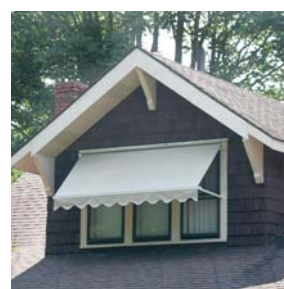

## ROOFS

Roofs are the greatest source of potential heat gain in the warmest months of the year when the midday sun is directly overhead. A light-colored, reflective roof surface is most effective in minimizing heat gain.

## OVERHANGS

Roof overhangs on the south side of the house can be sized to provide shade in the summer (when the sun is high in the sky), yet allow sunlight and warmth into the house in winter (when the sun is at a lower altitude). Overhangs also prevent water from draining directly onto the house and its foundation.

## PORCHES

Porches provide shade and outdoor living space with the south side of the house the most critical to shade. Screened porches provide breezy outdoor space while keeping out insects.

## SHUTTERS

Aesthetically pleasing, operable exterior shutters keep the hot sun out while allowing cooling breezes to ventilate the house. They also provide an effective window insulation system, enhanced weather protection, and household security.

## CEILING HEIGHT

Traditional architectural styles often use 12-foot ceilings, rather than the 8-foot baseline typical of new development. Higher ceilings, even 9 or 10 feet, provide more space for hot air to rise, increasing human comfort in warm weather. Coupled with large windows, higher ceilings also provide more effective ventilation.

## CEILING FANS

Ceiling fans increase comfort by providing air movement that aids the body's evaporative cooling system, rather than by regulating temperature. Fans also increase ventilation on outdoor porches and help keep away insects. Fans should be turned off when the room is not occupied.

## WINDOWS

Size, number, type, and placement of windows affect the comfort and energy efficiency of any house. Reduce the size and number of windows on the heat-intensive west side. Use larger windows for greater ventilation and day lighting on the north and east sides. Choose double-pane, insulated, and Low-E coated windows that hinder radiant heat flow through glass layers and allow in light and air. Double-hung windows are ideal for ventilation: cooler air enters through the raised bottom sash; hot air escapes through the lowered upper sash. All windows and doors should be sealed, flashed, and properly installed to reduce air and moisture infiltration.

## VEGETATED SHADING

Shade is a valuable and affordable resource that can be created by planting deciduous trees and shrubs on the west, east, southwest, and southeast sides of the house shades. This protects against solar heat gain in the summer and lets in sunlight in the winter. Small shrubs and groundcover used to shade pavement around the house, also keep the house and outdoor spaces cooler by reducing reflected heat.

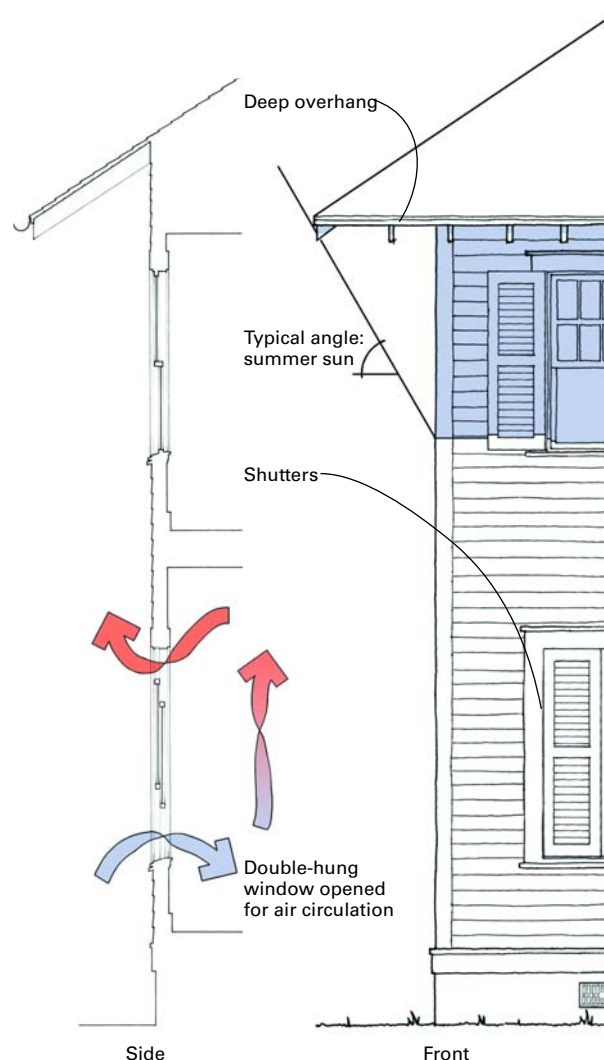

Correctly-proportioned overhangs and shutters provide shade, decreasing heat gain. Double-hung windows allow cooler air to enter through the raised bottom sash, while hot air escapes through the lowered upper sash. High ceilings allow hot air to rise above the occupied areas, increasing human comfort.



### WALL SECTION

A well-insulated, properly constructed exterior wall can increase the comfort, efficiency, and health of a house. Traditional wood framing is likely to remain the most common and accessible building system available. Framed houses, 2x6 Optimum Value Engineered (OVE) with structural sheathing, generally cost about the same as standard framed houses but have added benefits. OVE reduces framing time, lowers construction costs, conserves resources, and reduces annual energy costs. OVE also reduces the amount of lumber used in the exterior wall while increasing the insulation.

### INSULATION

Insulation is critical in building energy-efficient, comfortable houses. Insulation should exceed the required minimums to save on overall energy costs and make the house more comfortable. Use recycled wet-blown cellulose for better insulation and insect control.

### FOUNDATION SYSTEMS

Foundation systems should be carefully designed according to site characteristics. The well-built, well-insulated foundation can add greatly to the comfort and energy efficiency of a house.

### Materials and Indoor Air Quality

Initial decisions in the construction of a house can have a significant impact on maintenance and replacement costs over time. Consider selecting roof materials with extended warranties and using a cementitious fiberboard for siding. Selecting high quality materials and assemblies may add to upfront costs, but will likely provide long-term savings through greater durability, strength, and reduced replacement costs.

Because people spend an average of 65% of their time indoors, indoor air quality is critical to the health of residents, especially more vulnerable groups such as children, seniors, and individuals with existing respiratory problems and compromised immune systems. Toxic materials have associated negative human health effects including cancer, allergies, and 'sick building syndrome.' Sources of indoor air pollution include:

- >> Building materials and furnishings, such as insulation, carpeting, and cabinetry, that may contain phthalates, arsenic, and formaldehyde
- >> Polyvinyl chloride, commonly called PVC or vinyl is a hazard (approximately 75% of all PVC manufactured is used in construction materials)
- >> Adhesives that release formaldehyde
- >> Cleaning and maintenance products containing toxic chemicals
- >> Interior paints, primers, and removers that release volatile organic compounds

Materials should be selected with low or zero volatile organic compounds (VOCs), PVC, formaldehyde, arsenic, chromium, and other toxic chemicals. There are many alternative construction materials that can be used in place of vinyl including composite materials, fiber-cement board siding, metal roofing, natural linoleum, tile, wood flooring, sustainably-harvested wood, fiberglass, and aluminum windows and doors.

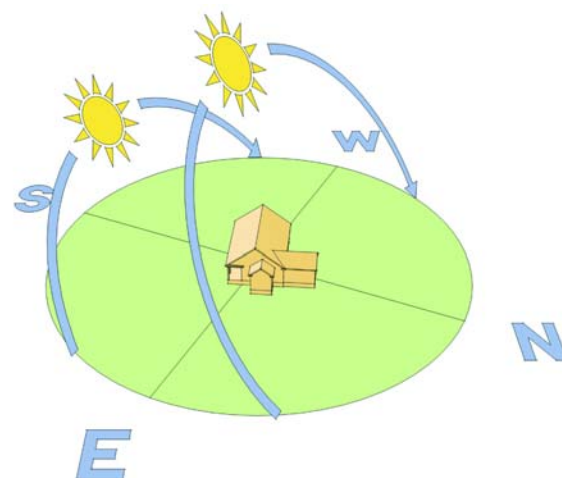

Keeping in mind the arc of the sun when orienting a house on a lot provides passive solar energy and can contribute to the overall energy efficiency of the house.



The background of the page is a detailed, light-colored illustration of a town from an aerial perspective. It shows a grid of streets, numerous houses with varying rooflines and gables, and scattered trees. The style is reminiscent of a watercolor or fine-line architectural drawing.

## SECTION G

# HOME OWNER'S GUIDE

This section of the Pattern Book is intended to assist Denton's home owners and those undertaking infill housing projects to build or renovate their houses. Following the more general information that appears on the opposite page about the basic components and form of a house, the section provides basic guidelines for making appropriate renovations, additions, and transformations to houses in Denton.

You'll want to use the information in this section in combination with that presented in the Architectural Styles section of the Pattern Book. There you'll find information about the three primary architectural styles in Denton (Victorian, Colonial Revival, and Craftsman), their characteristics, and the materials appropriate for each. At the end of that section, you'll also find a list of nationally respected Material Manufacturers that may be useful to you in selecting materials for your home improvement projects.

# Building the Denton House

Most traditional houses consist of a **Main Body** that is always the most important portion of the house's form. Additional space is treated as secondary additions to this Main Body.

The first step in designing your house is to determine the Main Body Massing Type. This will guide the development of your house plan or the modifications to your existing house.

In general, additions should be treated as **Wings**. Side wings can be either one, or one-and-one-half stories, set back from the front facade of the Main Body. Two-story additions can be added to two-story Main Bodies, but should be set back from the front facade and limited in width to a maximum of one-third the width of the Main Body. Side wings and rear wings can be added in many combinations.

Once the massing and the floor-to-floor heights have been determined, various **Window and Door Compositions** can be explored. Most traditional house styles have very definite patterns. These were used to create balanced or picturesque compositions that produce a harmonious and pleasing image. Window proportions, location, and spacing are all important and were well understood by early house builders.

**Porches** are important elements in the history and culture of Denton. These major elements are found in every architectural style or vocabulary. Setting the appropriate column types, porch cornices, railings, and balustrades are important to establishing the character of the house.

While **Windows and Doors** are available today from a wide range of manufacturers and come in almost any shape and size, selecting correctly proportioned and detailed Windows and Doors is key to creating or preserving the stylistic integrity of the design of your house. The Pattern Book illustrates standard window and door types used for each architectural style and special windows and doors used as accents.

The **Final Assembly** of the various components should produce a house of recognized character and quality, no matter what the size. Within the Architectural Styles Section, a series of three possibilities are provided for each style demonstrating the effective application of the Pattern Book guidelines.

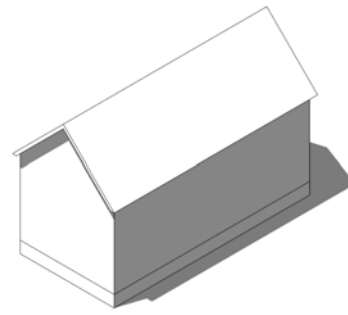

1 Main Body

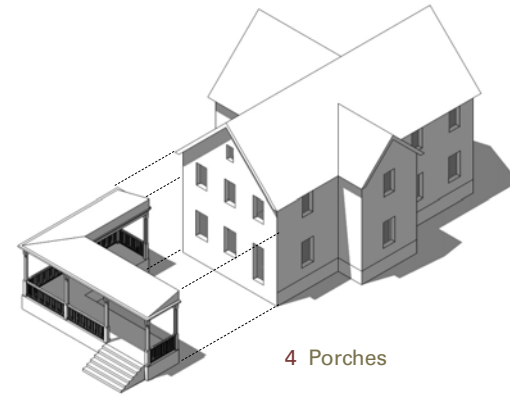

4 Porches

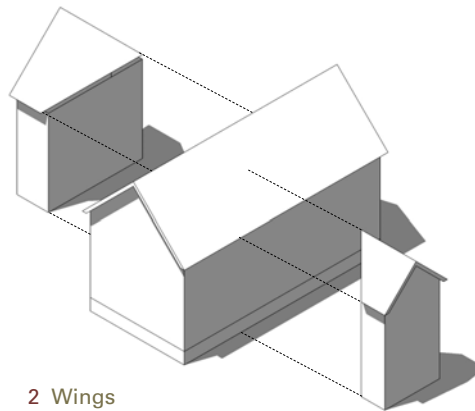

2 Wings

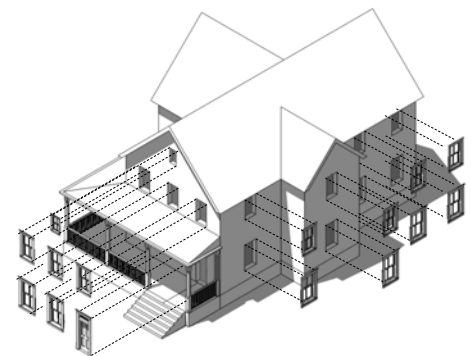

5 Windows and Doors



3 Window and Door Composition



6 Final Assembly

## Renovations



House renovations vary from applying a new coat of paint or replacing windows to adding an upper floor or a wing to a house. These options provide more living space while enhancing the quality and value of your house. A poorly executed renovation can turn even the most beautiful house into an eyesore regardless of the nature, extent, or major expenditure involved. Similarly, an inexpensive, but well-detailed modification to an existing house could add significant value.

The key to effective renovating lies in understanding the appropriate design elements, massing, and materials which create the architecture of your house.

### Scope

Before starting, it's important to determine the scope of your project. Is it cosmetic to help you add character and value? Or based on a need, such as additional living or parking space? Or is your purpose to repair old or damaged elements? By answering some simple questions about the scope of your project, the age of your house and its architectural style, you'll be better able to determine whether your project is a weekend project for you or a major building project requiring a professional and a building permit.

Renovations may include window replacement, a new front door, front porch restoration, roof and gutter replacement, brick repointing and repair, new paint, new



siding, or the replacement of aged or damaged siding. Larger renovations may include adding box and bay windows, dormers, and porches.

Additions are generally larger than renovations and may consist of major changes in terms of the massing of the house. Additions may include the construction of a wing – typically on the side or rear, the addition of a second habitable level, or the construction of an ancillary structure, such as a garage or carriage unit. In general, additions should reflect the architectural style of the main house body.

Transformations, on the other hand, are more drastic changes that allow the home owner to build value into an existing house by fitting it into one of the recognizable styles prevalent among the building traditions of Denton. Transformations are encouraged as they often result in a rise in property value and also further the contribution these structures make to the overall quality of the neighborhood.

### Age

After you have a sense of the size of your project, determine the age of your house. The age of your neighborhood may be a starting point. The Museum of Rural Life, as well as historic maps and governmental property data are all sources for finding the age and era of your house. Knowing the age of your house not only helps you understand the status of the building's structure, it also helps you decide whether the investments you're contemplating are worthwhile.

### Style

Finally, identify the architectural style of your house.

- 1 Determine its Massing Form by comparing the shape of your house to the massing possibilities of the significant Denton architectural styles.
- 2 Determine the Roof Pitch by measuring the vertical rise for the roof for every 12 inches of run. A 10 in 12 pitch means that the rafter rises 10 inches vertically for every 12 inches of horizontal distance. If you cannot measure your roof pitch, then visually approximate it to help assign a family style to it.
- 3 Refer to the Denton Architectural Style pages to find an appropriate style for your house. There you will find information on details and materials appropriate for each style and photographic examples of Denton houses to help you identify the style of your house and to serve as precedent examples for your project.

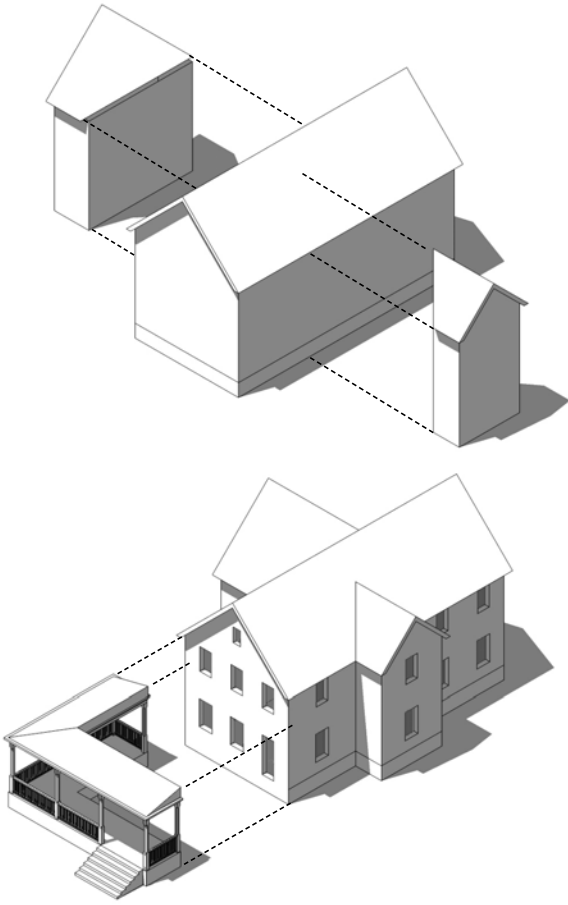

# Additions



Additions are a common house investment, often driven by the growth of families or the changes in living patterns compared to historic architectural development. To protect and enhance the value of your house, it is important to pay careful attention to the way you add onto it, ensuring that the house remains contextual in manner and that the addition reinforces the original facade composition.

Additions are generally larger than renovations and may consist of major changes to the massing of the house. Additions may include the construction of a wing typically on the side or rear, the addition of a second habitable level, or the construction of an ancillary structure (for example, a garage or carriage unit). In general, additions should reflect the architectural style of the main house body.

Successful additions add both beauty and value to the house while making the house more inhabitable to its residents. The facing page illustrates some of the design principles (presented below) applied to two possible additions, using existing houses in Denton as models. For each example, a photograph and two drawings present a comparative study of the house before and after the proposed addition. The massing composition diagram helps you visualize the effect of the addition on the overall lot layout.

The first step in determining what type of addition is appropriate is to understand the dimensions and massing of your existing house and lot so that an appropriately sized addition can be designed relative to the size of the main body.



## Side Wings

Particularly prevalent in the Colonial Revival and Victorian styles, side wings should step back no less than 2 feet from the front facade of the main body to ensure that the addition is subordinate in scale to the greater house.

Generally, the height of the main body governs the scale of any addition in terms of height and mass. No addition should be taller or more massive than the house to which it will be attached since to do otherwise would cause the addition and the house in its totality to look unnatural. Many examples of both good and poorly conceived additions can be found throughout Denton.

One-story wings should never exceed half the width of the Main Body of the house. Two-story wings should not exceed one-third of the house width. Wings may be built off either side of a house, however, particularly with the Colonial Revival style, two balanced wings are traditional. You can also balance a house wing with a garage or carriage porch/carport.

## Setbacks

Setbacks from the front facade are necessary to provide visual relief and hierarchy to the overall house. Garage or porch wings should be set back a distance equal to the width of the wing.



### Addition No.1

This house is typical of the many bungalows, loosely designed in the Colonial Revival style, throughout Denton. A rather common addition to a one-story house is the introduction of an additional bedroom or home office. Since many bungalows occupy similarly tight lots, and because many home owners do not wish to reduce outdoor space, such as the backyard, building living space into the roof is very common for this massing type.

In this particular example, multiple issues are resolved or improved by the addition of another half-story. Window and porch column rebuilding or refacing allows the bungalow to migrate into the Craftsman style, more typical for houses of this type. The porch columns recenter the entry and make for a balanced composition. The same Craftsman windows are used in the dormer, and the typical ganged set of windows allows much light into this second-story living space. The gable dormer is a type found frequently throughout Denton.



Existing House

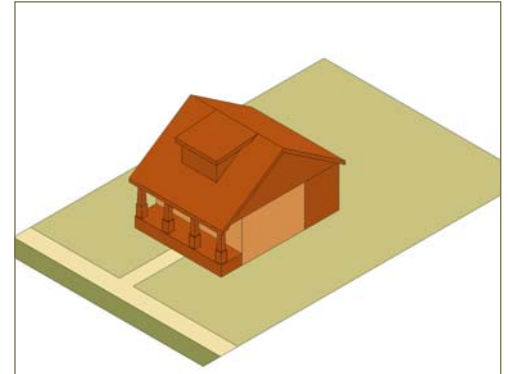

Massing Composition



Before Addition



After Addition

### Addition No.2

This house is another example of a building that is likely to be too small for most family types or residents. In order to address the issue of lack of living space, a two-story pop-up, or addition out the roof is illustrated. It provides a much larger house in the identical building footprint, creating additional interior square footage without consuming valuable yard space.

The house suffers from a lack of architectural character, though less so than a house in need of transformation. Properly-sized, shuttered windows arranged in a symmetrical manner create a traditional two-story Colonial Revival house, characteristic of those found throughout Denton. A portico is added to shield visitors and residents from the elements when entering the house. With this type of addition, much more substantial than the one shown above, this house is doubled in size, yet feels appropriate on its lot (as opposed to the extension of the main body mass itself).



Existing House

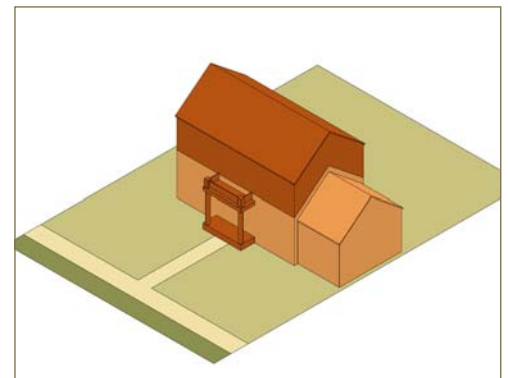

Massing Composition



Before Addition



After Addition

# Transformations



Many of Denton's blocks and streets, particularly those that reach out farthest from the core of town, were developed in later eras, long after the town's historic Victorian era development. Like most cities, this later influx brought with it myriad house types that often did not respect the pre-existing residential fabric surrounding them. In consequence, these houses look like the later insertions they were and often have nothing to do with the architectural heritage of their neighbors.

Sadly, much production building nowadays possesses the same telltale signs of placelessness resulting from a single-minded focus on mass production and efficiency over craftsmanship and character. Although the large homebuilding industry is firmly established in America, its effect and its potential erosion of the character of existing places need not continue as it is possible to build in a manner that is contextual and gets the details right for any house. Investing in the proper design of the transformation at the beginning of a building project goes a long way to eliminating the common problems of 'anywhere' houses – particularly complicated massing that attempts to make up for cheap materials and shoddy detailing.

The transformation examples are some of the most important in the Pattern Book because the guidelines speak to both renovation of existing structures, as well as developers' builder sets that can be tweaked in design to produce houses relating to Denton's existing fabric and

enduring traditions. The two transformations presented on the facing page provide direction for appropriately enlarging a house while also enhancing its existing architectural style references. Where no distinct style is apparent, refer to the Architectural Style pages to help you select an appropriate, distinctly Denton style and character based on the massing and proportions of your house.

Common transformation methods include the pop-up, nose, wing, and porch since these are most often the missing parts that traditional architectural vocabularies used to animate and create residential architecture. **Pop-ups** add living space by building a partial or full second floor on the house, or a half-story dormer. **Noses** are wings that face front and project into the front yard. These elements are not more than half the width of the house and must be at least 8 feet in width to be a usable interior space, usually as annexes to living and dining rooms. **Wings** project from the side and rear, and follow the proportional rules set out in the previous pages on additions. **Porches** are typically the most cost-effective addition, and often the introduction of a simple, well-scaled porch can do much to minimize the undesirable effects of poorly scaled or proportioned architectural elements that remain, such as windows, doors, and the like. In Denton, as in many other small towns throughout the region, front porch life provides more than outdoor living space, it also contributes to the sense of hometown feel.



### Transformation No.1

Beneath the siding of this Denton house likely lies other framed openings, and possibly another sheathing material altogether. Transforming it back into a consistent architectural style is a worthy goal, and will add a great deal of value to the house once it is seen as part of the overall community through the use of more direct architectural forms. In addition to the value added by style, more natural light and ventilation can be achieved by introducing additional second-story windows and a typical, wraparound porch which augments the amount of livable space without enveloping much of the lot.

Through transformation, the house shown here which was devoid of any style, can be identified as a Victorian house, in keeping with Denton's architectural heritage and traditions.



Existing House

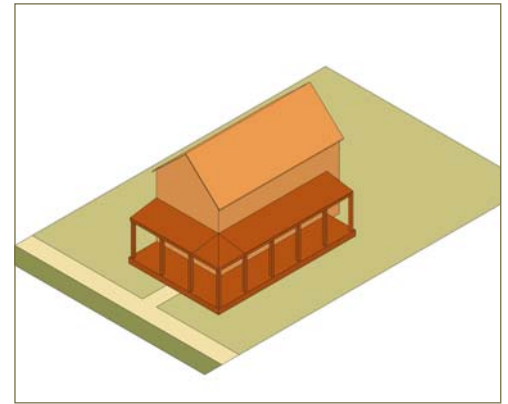

Massing Composition



Before Transformation



After Transformation

### Transformation No.2

This relatively small house can take full advantage of its wider, shallower lot through the addition of a wing and new roof with dormers for extra upstairs living space. In this case, the wing is shown as a garage since the current house lacks an indoor parking space and that form of storage.

In terms of the active living space, much of the investment is applied to gaining more natural light in the form of larger, operable, well-proportioned windows. Operable windows in the three dormers on the second story also provide new opportunities for upstairs rooms, such as bedrooms or a second bath. With the addition of second-story living space, the roof pitches which were formerly shallow, can take on the appropriate pitch for a Colonial Revival house, a style which this house can now rightfully claim.



Existing House

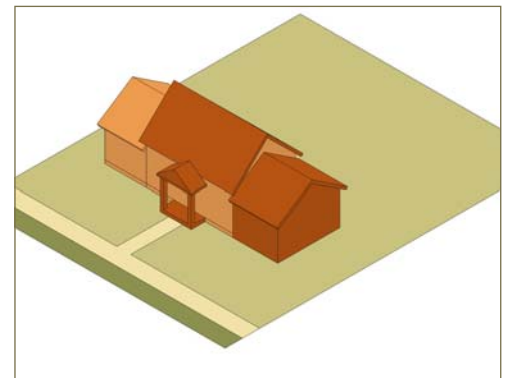

Massing Composition



Before Transformation



After Transformation

## Garages, Driveways, and Yards



The landscape elements in front yards, particularly garages and driveways greatly affect the overall character of the lot. These elements strike the balance between the landscaping of the individual house and its contribution to the overall character of the street. Wide variations in these elements exist among the five neighborhood types described in Section B of this Pattern Book. There are also elements which unite them all.

### Garages

The principal issues with garages are the size, location, and detailing for the doors, as well as garage additions that often overwhelm the scale and character of the house.

For houses on corner lots, the garage should be located in the rear yard, turned to face the side street, and set back to match the house setback. It is preferable to locate the garage so that the parking area in front of the garage is at least 18 feet inboard of the side street property line to prevent parked cars from encroaching into the public sidewalk. Corner lots are also good places for two- or three-car carriage houses incorporating small apartments above. Single-width garage doors up to 8 feet wide are recommended. Large double-width doors are not in keeping with the scale of houses. Paneled door styles appropriate to the style of the house should be used.

In many cases, there may be enough room to build up to a three-car garage in the rear yard of a relatively narrow lot. Access to the garage is typically from a narrow driveway, usually 8 to 9 feet wide, that slips along one side of the house.

A carriage porch, or carport, is often used to provide a drop-off at the house, as well as screen the back yard from the street. It is recommended that the garage be placed in the rear of the lot to provide turnaround space between the house and the garage.



If an attached garage is preferred, a one-car garage is recommended. This garage must be placed behind a line established at the intersection of a 45-degree line (cast on the ground plane from the front corner of the house) and the side setback or driveway line. This proportion creates garages that do not overburden the main body of the house. Attached two-car garage additions often appear wider than the house, which is not recommended.

Attached one-car garages should be treated as wing additions in terms of setback from the front of the house (45 degree rule noted above). Their architectural character should match that of the house.

### Driveways

Driveways should be seen as landscape elements within the yard that enhance the beauty and setting of the house and garage, if present. As such, driveways should not be dominant elements on house lots. Whenever possible, porous, natural materials or special materials (stone, brick, crushed stone, or pebbles), should be used to blend in driveways with the surrounding yard or garden space. In particular, using large expanses of cement as a driveway material tends to detract from the character of the house. If cement is used, it should only be poured for the tire tracks, or for a single driveway that slips past the house as unnoticeably as possible.

### Yards

The gallery of photos illustrate some of the best practices in planting yards to make them inviting extensions of the private realm into the public realm and design of the streets and neighborhoods. For more information about appropriate plant materials and environmentally responsible landscape design, refer to the final section of this Pattern Book, Environmentally Responsible Landscape Design, which follows immediately.



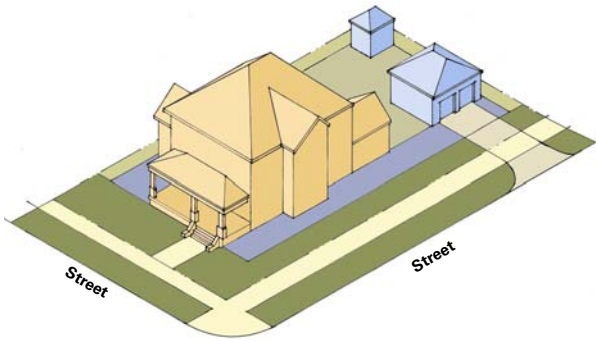

Ancillary structures include storage sheds and detached garages on a corner lot



Garage and carriage house types

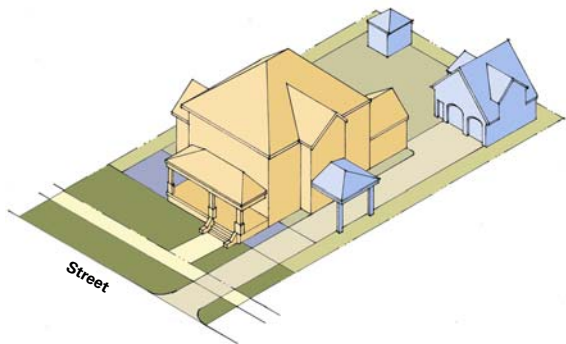

Driveway types

A carriage porch or carport and a carriage house shown on a mid-block lot

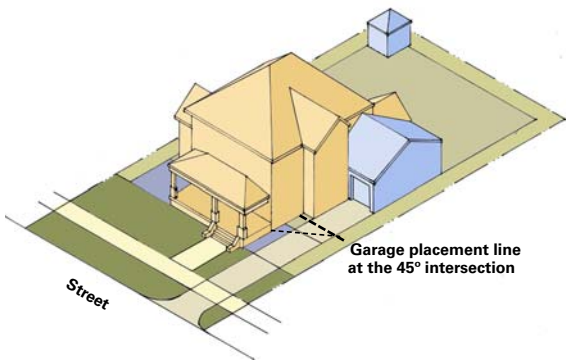

An attached garage and a storage shed on a mid-block lot

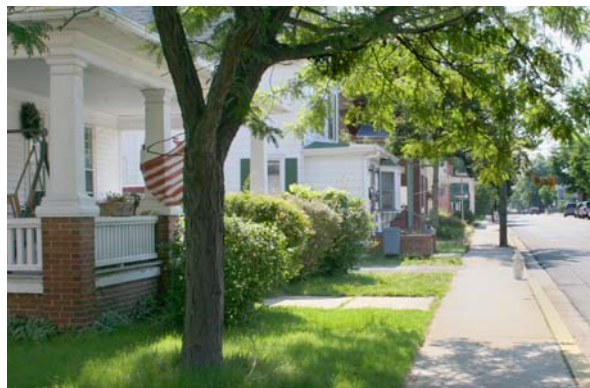

## SECTION H

# ENVIRONMENTALLY RESPONSIBLE LANDSCAPE DESIGN

The Eastern Shore of Maryland has wonderful watersheds, marshes, and wetlands, as well as agricultural lands between its various towns and villages. Denton's location along the Choptank River and within the Chesapeake Bay watershed of Maryland's Eastern Shore contributes strongly to the town's character and sense of place. How we as citizens relate to and interact with these resources – which are of economic value to our community – is critical in protecting and preserving them as assets of our town.

This section of the Pattern Book presents specific techniques for environmentally responsible landscape design. Overall, these techniques are intended to conserve water, reduce energy consumption, and lessen the impact on our streams, rivers and the Bay. In many cases, the techniques will also improve habitat and save the property owner time, energy and money in ongoing maintenance.

By applying these techniques to any new development, redevelopment, or redesign of existing residential landscape in Denton, we can each do our part to be responsible stewards of our precious resources. On the pages which follow, home owners, builders, developers, and landscape architects will find a series of readily implementable techniques from which to choose. We encourage you to use as many of these as possible for your particular project.

To further assist you in making environmentally responsible landscape design decisions, we've included a Plant Palette which identifies plant materials appropriate for use in Denton. Non-native and exotic plant materials are strongly discouraged as they typically require frequent watering, considerable maintenance, and have the potential to become invasive, crowding out native plant species and upsetting the ecological balance of the region. The section concludes with a Landscape Resources list to help you obtain additional information and assistance in adopting the techniques presented.

# Strategies and Techniques

As a compact, mixed-use town, Denton, by its very nature, does its part to strike a balance between the man-made and natural environments. Denton is committed to promoting the widespread use of environmentally responsible, sustainable, landscape design practices in our community.

In the chart on this page, you'll find a number of specific techniques you can use to practice environmentally responsible landscape design around your home or for your development project. The techniques presented are by no means an exhaustive list of the possibilities. Rather, they are some of the most common and most easily implemented. Home owners, builders and developers are encouraged to incorporate as many of these techniques as possible in their particular realm.

Builders, developers and landscape architects should note that the State of Maryland requires that certain visionary elements be incorporated into all local plans.

The information presented in this section responds to these three visionary elements contained in the State Comprehensive Planning Requirements:

- >> Sensitive areas are protected.
- >> Stewardship of the Chesapeake Bay and the land is a universal ethic.
- >> Conservation of resources, including a reduction in resource consumption, is practiced.

In addition, local and State development regulations and building codes establish minimum performance standards for land development and construction. The environmental design techniques presented in this section will assist you in achieving some of the goals and objectives set forth in the Denton Comprehensive Plan. The techniques also supplement the development and design standards in the Denton Zoning Ordinance and Subdivision Regulations.

## SOME ENVIRONMENTALLY RESPONSIBLE LANDSCAPE DESIGN TECHNIQUES

Technique	Domestic Initiatives	Infill/ Redevelopment	Large-Scale Development
» Use Native Plants and Materials	×	×	
» Install a Rain Barrel	×	×	×
» Establish a Rain Garden	×		
» Make House More Energy Efficient	×	×	×
» Reduce Impervious Surfaces		×	×
» Environmentally Treat Stormwater		×	×
» Utilize Surrounding Environment		×	
» Plan Neighborhood Design			×
» Design for Pedestrians			×

### A Few Key Principles

- >> Land Stewardship
  - Avoid environmentally sensitive sites and lands located in designated greenbelt areas.
  - Encourage selection of infill sites already served by existing infrastructure.
  - Design and construct buildings with minimal impact on the building lot.
- >> Community and Neighborhood Character
  - Promote environmentally and socially responsible land development.
  - Minimize dependence on automobiles by encouraging patterns that allow for alternative means of transportation, such as walking, biking, and transit.
  - Encourage compact development patterns in order to use land efficiently and conserve natural lands.
- >> Environmental Design
  - Install landscapes that minimize water demand.
  - Minimize erosion and run-off from sites.
  - Avoid use of poisons for insect and disease control.
  - Reduce local heat island effects by use of shading.



### Use Native Plants, Grasses and Materials

Use plants, grasses and materials native to the region. When shopping for plant materials at a nursery, be sure to let them know you prefer to use native plants. They're naturally suited for this environment, reduce the need for chemical pesticides and herbicides, help control unwanted pests, can provide wildlife habitat, and typically save you time and money in the upkeep of your garden.

Deep rooted plants, such as most trees, shrubs, and perennials make better use of rain water than typical lawn grasses, and so require less watering once established. These plants are also better at trapping and removing nitrogen and pollutants from rain water so that they are not released into nearby bodies of water.



### Install a Rain Barrel

Relatively simple and inexpensive to construct, a rain barrel can sit conveniently under any residential gutter downspout, collecting and storing water from your roof for use when you need it most – during periods of drought – to water plants, wash your car, or top off a swimming pool.

Rain barrels help protect the environment and save money and energy by decreasing the demand for treated tap water. They provide home owners with an ample supply of free 'soft water' containing no chlorine, lime or calcium, making the water ideal for gardens, flower pots, and car and window washing. They also divert water from storm drains, decreasing the impact of runoff to streams and the Chesapeake Bay. A rain barrel is an easy way for you to 'Save the Bay' and have a consistent supply of clean, fresh water for outdoor use.

If the rain barrel is hooked to a drip irrigation system or used regularly, there should be little maintenance required. During drier months or with little use, the barrel may require seasonal cleaning.

Installing a rain barrel will save most home owners about 1,300 gallons of water during peak summer months.

### Establish a Rain Garden

A rain garden is a specifically designed landscaped area that allows rainwater to naturally collect and soak into the ground. Water can be directed to these gardens straight from rooftop downspouts, driveways and other paved areas. Rain gardens slow the rush of water from these hard surfaces, hold the water for a short period of time, and allow it to naturally infiltrate into the ground.



Rain gardens help filter runoff pollution, recharge local groundwater, conserve water, reduce the potential of house flooding, and create habitat for birds and butterflies. While they will need less maintenance than more manicured gardens, rain gardens are not completely maintenance-free. They will need to be weeded, cleaned-up, and re-mulched in the early spring and fall.

Simple rain gardens are 3- to 6-inch-deep, saucer-shaped depressions. While rain garden dimensions vary, remember, any size rain garden is better than no rain garden at all.

### Make Your House More Energy Efficient

Reduce your energy bills – and be kind to the environment at the same time – by making your house more energy efficient. There are many ways to save money and use less energy in your home. Some techniques need to be installed during the construction of the house, but many can be added at any time. Techniques include: selecting only those heating and cooling systems, insulation, windows, doors, and appliances that have high energy efficiency ratings; using solar panels and compact fluorescent light bulbs instead of traditional incandescent bulbs; making it a habit to turn off lights and computers when not in use; and applying water conservation methods.

While some of these techniques may cost a bit more upfront, they typically recoup that additional cost quickly as well as provide subsequent cost savings. For example, while compact fluorescent light bulbs cost more than traditional bulbs, they last for years and use a fraction of the energy. ENERGY STAR appliances also cost more upfront, but they enable home owners to quickly recoup that additional cost through higher energy efficiency and then provide the home owner with ongoing savings over the life of the appliances.

If every household in the U.S. replaced one light bulb with an ENERGY STAR qualified compact fluorescent lamp (CFL), it would prevent enough pollution to equal removing one million cars from the road.

Home owners can enjoy up to 40% energy savings from shade trees in the summer and pine trees in the winter that block cold winds.

### Reduce Impervious Surfaces

Minimizing the amount of impervious surface will reduce peak discharge, total volume and the amount of stormwater that needs to be treated, help increase groundwater

recharge, lessen the disruption of the water cycle, improve site appearance, and may also save money by installing less pavement. To reduce impervious surfaces, make streets narrower, design for shared parking, incorporate compact car spaces and grassy sections in parking areas, and use surfaces for parking that allow water to infiltrate back to the ground before it would run off.

Although accommodating emergency vehicle width on the site is an important consideration for developers, many roads can be reduced from conventional standards and still allow for buses and emergency vehicles to travel safely. Permeable paving is not appropriate in soils with low permeability or high shrink-swell potential (for example, tight clay). Also, systems such as reinforced grass paving can only be used for low traffic volume areas.

Allowing rainwater to locally infiltrate through a permeable paving system can decrease the amount of runoff leaving the site by up to 90%, facilitate pollutant removal, help to control streambed and riverbank erosion, provide for ground water recharge, and create a more aesthetically pleasing landscape.

### Environmentally Treat Stormwater

Incorporating non-structural techniques for treating rainwater from the site before it reaches the local stormwater system is a highly environmentally responsible method for removing pollutants and allowing water to infiltrate back into the ground instead of directing the water off-site to a stormwater drain. A variety of techniques – ranging from the very simple to more technical – can be used to accomplish this. Among them are landscaped bioretention areas with locally adapted plants, grass filter strips, and vegetated swales. Whatever techniques are employed, the goal is to design the project so that rainwater is directed into the natural treatment systems by the slope of the parking area, curb cuts, or downspouts. Conventional stormwater systems can still be used as a backup for large storm events, but should follow the non-structural treatments.

### Utilize the Surrounding Environment

Taking advantage of existing building structures as well as community resources such as adjacent neighborhoods, parks, open space, sidewalks, and parking areas will enhance the environmental responsiveness and sensitivity of any project's design. This technique creates wonderful opportunities to repair past or avoid future environmental damage, stop pollutant loading and improve water quality, restore or preserve wildlife habitat and nat-

ural spaces and corridors, save money, utilize existing buildings, and provide community connections which make infill, redevelopment, or new development projects feel like an integral part of the community.

### Carefully Plan the Neighborhood Design

When designing a new neighborhood, it's important to minimize its footprint, design for pedestrian movement throughout the community, and incorporate energy efficiency into the construction of all new buildings in order to minimize the impact of the new development on the environment. Concentrating houses and other structures on a smaller portion of land will allow most of the land to remain in its natural condition. This reduces clearing costs, creates more efficient street and utility patterns, maintains habitat and green infrastructure, maintains more pre-development hydrology conditions, and improves the overall appearance of the developed project. As open space is set aside, a clear plan for management and ownership of the land should be established (County, Land Trust or Homeowners Association).

When new residential or commercial development is grouped the result can minimize visual impact, preserve workable farmland, connect neighborhoods and other recreation areas through trails, and can provide vegetated buffers to reduce runoff and maintain water quality.

### Design for Pedestrians

Designing for pedestrians means incorporating alternative transportation modes into the neighborhood, including bike and pedestrian pathways. It also requires that destinations such as schools, libraries and commercial areas be located within walking distance from residential areas. Some of the environmental benefits derived from making neighborhoods pedestrian-friendly include reduced vehicle emissions, improved air quality, health benefits to community residents, and a range of transportation choices. Pedestrian pathways must allow for the safe movement of pedestrians through an area including personal safety (lighting, access) in addition to safety from vehicular traffic (grass strips or parking lane between walkways and roads).

More Marylanders die each year from cardiovascular disease than from all forms of cancer, AIDS, suicide, and traffic injuries combined. According to the Centers for Disease Control and Prevention, moderate physical activity such as walking and bicycling offers substantial health benefits.



## Plant Palette

General Class	Scientific name	Common Name	Soil Moisture	Sunlight	Height	Color	Bloom
Fern	<i>Botrychium virginianum</i>	rattlesnake fern	M/D	PS/SH	1.5 ft		
Fern	<i>Osmunda regalis</i>	royal fern	W/M	S/PS/SH	2–3 ft		
Grass	<i>Carex pensylvanica</i>	sedge	D	PS/SH	0.5–1.5 ft	R/W	May–Jun
Grass	<i>Panicum virgatum</i>	Virginia switchgrass	W/M	S	3–6 ft		Jul–Oct
Grass	<i>Schizachyrium scoparium</i>	little bluestem	D	S/PS	4 ft		Aug–Oct
Groundcover	<i>Chrysogonum virginianum</i>	green-and-gold	M/D	PS	1 ft	Y	Mar–Jun
Groundcover	<i>Sedum ternatum</i>	mountain stonecrop	M	PS/SH	1 ft	G/W	Apr
Herbaceous	<i>Asclepias syriaca</i>	common milk weed	D	S	6 ft	Pu	Jun–Aug
Herbaceous	<i>Aster novae-angliae</i>	New England aster	M/D	S/PS	6 ft	Pu	Sept–Oct
Herbaceous	<i>Caltha palustris</i>	marsh marigold	W/M	S/PS	1–2 ft	Y	Apr–Juny
Herbaceous	<i>Chrysogonum virginianum</i>	green-and-gold	M/D	PS	1 ft	Y	Mar–Jun
Herbaceous	<i>Eupatorium dubium</i>	Joe-Pye weed	W/M	S/PS	4–7 ft	Pu	Jul–Sep
Herbaceous	<i>Eupatorium fistulosum</i>	Joe-Pye weed	M/D	S/PS	1.5–6 ft	P	Jul–Sep
Herbaceous	<i>Liatris spicata</i>	<i>gayfreather, blazingstar</i>	W/M	S	3 ft	Pu	Aug–Oct
Herbaceous	<i>Lobelia cardinalis</i>	cardinal flower	W/M	S/PS	3 ft	R	Jul–Sep
Herbaceous	<i>Polygonatum biflorum</i>	Solomon's seal	M/D	PS/SH	0.5-2 ft	W	May–Jun
Herbaceous	<i>Rudbeckia hirta</i>	black-eyed Susan	M/D	S/PS	2 ft	Y	Jun–Oct
Herbaceous	<i>Tradescantia virginiana</i>	Virginia spiderwort	M	S/PS/SH	2–3 ft	Bl/Pu	Apr–Jun
Herbaceous	<i>Trillium grandiflorum</i>	white trillium	M	SH	1 ft	W	Apr–Jun
Tree small/medium	<i>Asimina triloba</i>	paw paw	M	S	39 ft	Y/R	Mar–Apr
Tree small/medium	<i>Cornus florida</i>	flowering dogwood	M/D	PS/SH	35–50 ft	W	Apr–May
Tree small/medium	<i>Ilex opaca</i>	American holly	M	S/PS	65 ft	W	May–Jun
Tree small/medium	<i>Juniperus virginiana</i>	eastern red cedar	M/D	S/PS	50 ft		Mar–Apr
Tree small/medium	<i>Pyrus (Malus) coronaria</i>	sweet crabapple	M	S	20–26 ft	P	Apr–May
Tree Tall (canopy)	<i>Acer rubrum</i>	red maple	W/M	S/PS	40–60 ft		
Tree Tall (canopy)	<i>Betula nigra</i>	river birch	W/M	S/PS	30–50 ft		
Tree Tall (canopy)	<i>Fagus grandifolia</i>	American beech	M	S/PS	50–100 ft		
Tree Tall (canopy)	<i>Pinus taeda</i>	loblolly pine	W/M	S	70–90 ft		
Tree Tall (canopy)	<i>Pinus virginiana</i>	Virginia pine	M/D	S	50–80 ft		
Tree Tall (canopy)	<i>Quercus marilandica</i>	blackjack oak	D	PS	50 ft		
Tree Tall (canopy)	<i>Ulmus americana</i>	American elm	M	S	100 ft		



Joe-Pye weed (*Eupatorium dubium*)



Green and gold groundcover (*Chrysogonum virginianum*)



Black-eyed Susan (*Rudbeckia hirta*)



Virginia switchgrass (*Panicum virgatum*)



Sedg (*Carex pensylvanica*)



Little bluestem (*Cchizachyrium scoparium*)



American holly (*Ilex opaca*)



American beech (*Fagus grandifolia*)



American elm (*Ulmus americana*)



Eastern red cedar (*Juniperus virginiana*)

## Landscape Resources

The following partial list of landscape resources (developed by the Maryland Department of Natural Resources) provides a starting point for home owners in identifying appropriate strategies for landscaping and green building in their home improvement efforts. These resources augment the information provided in this Pattern Book and can assist you in implementing the techniques presented.

### Use Native Plants

For information:

- >> Maryland Department of Natural Resources  
[[www.dnr.maryland.gov/ed/landscape.html](http://www.dnr.maryland.gov/ed/landscape.html)]
- >> US Fish and Wildlife's BayScaping Program  
[[www.fws.gov/chesapeakebay/Bayscapes.htm](http://www.fws.gov/chesapeakebay/Bayscapes.htm)]
- >> Alliance for the Chesapeake Bay's BayScaping Program  
[[www.alliancechesbay.org/bayscapes.cfm](http://www.alliancechesbay.org/bayscapes.cfm)]
- >> Maryland Native Plant Society [www.mdflora.org]

To purchase native species:

- >> Adkins Arboretum: Ridgely, MD  
[[www.adkinsarboretum.org](http://www.adkinsarboretum.org)]
- >> Environmental Concern, Inc. : St. Michael's, MD  
[[www.wetland.org](http://www.wetland.org)]
- >> Eastern Shore Nurseries, Easton, MD  
[410/822-1320]
- >> Water's Edge Nursery: Federalsburg, MD  
[410/479-9037]
- >> Ed Collins' Greenhouses: Preston, MD  
[410/673-7361]
- >> John S. Ayton State Tree Nursery  
[[www.dnr.state.md.us/forests/nursery](http://www.dnr.state.md.us/forests/nursery)]

### Install A Rain Barrel

For information:

- >> Maryland Department of Natural Resources  
[<http://www.dnr.state.md.us/ed/rainbarrel.html>]
- >> Arlington Echo Outdoor Education Center  
[[www.arlingtonecho.net/rainbarrel.htm](http://www.arlingtonecho.net/rainbarrel.htm)]

To purchase a rainbarrel:

- >> Arlington Echo Outdoor Environmental Center  
[[www.arlingtonecho.net/rainbarrel.htm](http://www.arlingtonecho.net/rainbarrel.htm)]

How to make your own rain barrel:

- >> Maryland Department of Natural Resources  
[[www.dnr.state.md.us/ed/rainbarrel.html](http://www.dnr.state.md.us/ed/rainbarrel.html)]
- >> [www.rainbarrelsandmore.com]
- >> [www.composters.com]

### Establish A Rain Garden

For information:

- >> The Rain Garden Network  
[[www.raingardennetwork.com](http://www.raingardennetwork.com)]
- >> Maryland Department of Natural Resources  
[[www.dnr.state.md.us/ed/editorials/RainGarden-Final.pdf](http://www.dnr.state.md.us/ed/editorials/RainGarden-Final.pdf)]
- >> Prince George's County Maryland  
[[www.goprincegeorgescounty.com/pgcounty/government/agencyindex/der/ppd/lid/bioretenion.asp](http://www.goprincegeorgescounty.com/pgcounty/government/agencyindex/der/ppd/lid/bioretenion.asp)]
- >> Weems Creek Conservancy  
[[www.weemscreek.org/proj-mine-raingarden.html](http://www.weemscreek.org/proj-mine-raingarden.html)]

### Make Your House More Energy Efficient

For information:

- >> Maryland Department of Natural Resources  
[[www.dnr.state.md.us/ed](http://www.dnr.state.md.us/ed)]
- >> Maryland Energy Administration  
[[www.energy.state.md.us](http://www.energy.state.md.us)]
- >> Energy Star  
[[www.energystar.gov](http://www.energystar.gov)]

To purchase energy efficient materials:

- >> Most materials are available at your local hardware store or on the web

### Reduce Imperivous Surfaces

For information on roadway and parking lot design:

- >> Boston Metropolitan Area Planning Council  
[[www.mapc.org/regional\\_planning/LID/roadways\\_parking\\_lots.html](http://www.mapc.org/regional_planning/LID/roadways_parking_lots.html)]
- >> US Environmental Protection Agency  
[[www.epa.gov/owow/nps/lid](http://www.epa.gov/owow/nps/lid)]

For information on permeable paving:

- >> Low Impact Development Center  
[[www.lowimpactdevelopment.org/epa03/pavespec.htm](http://www.lowimpactdevelopment.org/epa03/pavespec.htm)]
- >> [[www.lid-stormwater.net/permeable\\_pavers/permpavers\\_benefits.htm](http://www.lid-stormwater.net/permeable_pavers/permpavers_benefits.htm)]
- >> Cahill Associates  
[[www.thcahill.com/pub.html](http://www.thcahill.com/pub.html)]
- >> Most permeable paving materials can be found at local suppliers using specs from the above mentioned websites.

### Environmentally Treat Stormwater

For more general environmental design information:

- >> Maryland Department of the Environment  
[[www.mde.state.md.us/assets/document/chapter5.pdf](http://www.mde.state.md.us/assets/document/chapter5.pdf)]
- >> Maryland Department of Natural Resources  
[[www.dnr.state.md.us/ed](http://www.dnr.state.md.us/ed)]
- >> Boston Metropolitan Area Planning Council  
[[www.mapc.org/LID.html](http://www.mapc.org/LID.html)]
- >> Low Impact Development Center  
[[www.lowimpactdevelopment.org](http://www.lowimpactdevelopment.org)]
- >> Center for Watershed Protection  
[[www.cwp.org](http://www.cwp.org)]
- >> Most commercial design and construction firms are versed in these techniques.

For more information on bioretention areas:

- >> Boston Metropolitan Area Planning Council  
[[www.mapc.org/LID.html](http://www.mapc.org/LID.html)]
- >> US Environmental Protection Agency  
[[www.cwp.org/Downloads/ELC\\_PWP110.pdf](http://www.cwp.org/Downloads/ELC_PWP110.pdf)]
- >> Low Impact Development Center  
[[www.lowimpactdevelopment.org/epa03/biospec.htm](http://www.lowimpactdevelopment.org/epa03/biospec.htm)]
- >> Federal Highway Agency  
[[www.fhwa.dot.gov/environment.ultraurb/3fs3.htm](http://www.fhwa.dot.gov/environment.ultraurb/3fs3.htm)]

For more information on grass filter strips:

- >> Boston Metropolitan Area Planning Council  
[[www.mapc.org/regional\\_planning/LID/grass\\_strip\\_filters.html](http://www.mapc.org/regional_planning/LID/grass_strip_filters.html)]
- >> Stormwater Managers Resource Center, operated by the Center for Watershed Protection  
[[www.stormwatercenter.net](http://www.stormwatercenter.net) (select Fact Sheets; Stormwater Management; scroll down to Stormwater Management Practices; select Grassed Filter Strip from pulldown menu)]
- >> The Maryland Stormwater Design Manual  
[www.mde.state.md.us/assets/document/chapter5.pdf](http://www.mde.state.md.us/assets/document/chapter5.pdf)

For more information on vegetated swales:

- >> Environmental Protection Agency  
[[www.epa.gov/owmitnet/mbt/vegswale.pdf](http://www.epa.gov/owmitnet/mbt/vegswale.pdf)]
- >> Boston Metropolitan Area Planning Council  
[[www.mapc.org/regional\\_planning/LID/swales.html](http://www.mapc.org/regional_planning/LID/swales.html)]
- >> Low Impact Development Center  
[[www.lowimpactdevelopment.org/epa03/LIDrans/L07\\_Swales.pdf](http://www.lowimpactdevelopment.org/epa03/LIDrans/L07_Swales.pdf)]

### Utilize Surrounding Environment

For information:

- >> Maryland Department of Planning  
[[www.mdp.state.md.us](http://www.mdp.state.md.us)]
- >> Urban Land Institute  
[[www.uli.org](http://www.uli.org)]

### Design for Pedestrians

For more information:

- >> The International City/County Management Association  
[[www.icma.org/main/topic.asp?tpid=31&chsid=1](http://www.icma.org/main/topic.asp?tpid=31&chsid=1)]
- >> Fact Sheet on Design for Biking and Walking  
[[www.icma.org/upload/library/2004-04/{1E040E8A-4A45-4BC0-B560-07D8BD2CE6D1}.pdf](http://www.icma.org/upload/library/2004-04/{1E040E8A-4A45-4BC0-B560-07D8BD2CE6D1}.pdf)]
- >> Walkable Communities, Inc.  
[[www.walkable.org](http://www.walkable.org)]
- >> Healthy U of Delmarva  
[[www.healthyu.delmarva.org](http://www.healthyu.delmarva.org)]

## Glossary of Terms

- Architectural Vocabulary** A collection of related architectural elements, materials or stylistic conventions used to describe a building or structure.
- Architrave** The lowest part of an entablature, sometimes used by itself.
- Backband** A rabbeted molding applied to the outside perimeter of window and door casing to create a thicker appearance.
- Balustrade** An entire railing system including a top rail, balusters, and often a bottom rail.
- Bioretention** A water quality practice that utilizes landscaping and soils to treat stormwater runoff by collecting it before filtering through a fabricated planting soil media.
- Boxed Eave (boxed cornice)** A hollow eave enclosed by the roofing, the soffit and the building wall.
- Brickmold** Window or door trim, typically 2 inches wide.
- Carriage Porch** A roofed structure over a driveway at the door to a building, protecting those entering or leaving a vehicle from the weather.
- Cartway** That part of a road or street that is reserved for unimpeded vehicular travel.
- Casement** A window sash which swings open along its entire length; usually on hinges fixed to the sides.
- Colonial Revival** In the U.S. in the late nineteenth and early twentieth centuries, style utilizing American Georgian and colonial design.
- Common Bond** Brick masonry bond pattern of one course of headers to every three to five stretcher-courses.
- Corner Board** A board which is used as trim on the external corner of a wood-frame structure.
- Cornice** An ornamental molding at the meeting of the roof and walls; usually consists of bed molding, soffit, fascia, and crown molding.
- Dentil** One of a band of small, square, tooth-like blocks forming part of the characteristic ornamentation of some classical orders.
- Encroachments** Permitted intrusion into required setbacks.
- Entablature** In classical architecture, the elaborated beam member carried by the columns, horizontally divided into architrave, frieze, and cornice.
- Facade Zone** Designated area for the principal front and/or side face of a structure.
- Fascia** Generally, the vertical band or member that terminates a roof at the eave.
- Filter Strips** A vegetated area that treats ground water flow by removing sediment and other pollutants.
- Frieze** The middle horizontal member of a classical entablature, above the architrave and below the cornice.
- Front Yard Setback** Minimum distance between the front property line and the Front Facade Zone.
- Gable** The vertical triangular portion of the end of a building having a double-sloping roof, from the level of the cornice or eaves to the ridge of the roof.
- Gable L** Describes the massing of a house having a hipped roof with a projecting gable form at the front, typically two-thirds the width of the facade.
- Gable Roof** A roof having a gable at one or both ends.
- Gambrel Roof** A ridged roof with two slopes on each side, the lower slope having the steeper pitch.
- Georgian Colonial** The Classically-inspired architecture of the British colonies in North America; monumental, symmetrical, and richly decorated.
- Hipped Roof** A roof that slopes upward from all four sides of a building, requiring a hip rafter at each corner.
- Impervious/Impermeable** Material which prevents the infiltration or passage of liquid through it; any surface in the urban landscape that cannot effectively absorb or infiltrate rainfall.
- Ionic Order** The classical order of architecture characterized by its capital with large volutes, a fasciated entablature, continuous frieze, usually dentils in the cornice, and by its elegant detailing.
- Knee wall** Short, vertical partition wall that closes off the low space created by a sloping ceiling and the floor.
- Light** A pane of glass, a window or a subdivision of a window.

**Lintel** A horizontal structural member (such as a beam) over an opening which carries the weight of the wall above it.

**Louver** An assembly of sloping, overlapping blades or slats designed to admit air and/or light and exclude rain and snow.

**Mullion and Muntin** The vertical and horizontal members separating (and often supporting) windows, doors, or panels set in series.

**Ogee Curve** A double curve resembling an S-shape.

**Pediment** In classical architecture, the triangular gable end of the roof above the horizontal cornice. Also, a surface used ornamentally over doors or windows.

**Pilaster** An engaged pier or pillar, often with capital and base.

**Porte cochère** Large doorway that permits wheeled vehicles to enter from the street; also a carriage porch.

**Portico** A porch or covered walk consisting of a roof supported by columns; a colonnaded porch.

**Private Zone** Designated area of the lot between the Facade Zone(s) and Setbacks.

**Rafter Tails** A rafter, bracket, or joist which projects beyond the side of a building and supports an overhanging portion of the roof.

**Rain Barrel** A barrel that has been outfitted as a temporary storage container, connected to a roof downspout, typically including a hose attachment to allow for reuse of rooftop runoff.

**Rear Yard Setback** Minimum distance between the rear property line and the Private Zone.

**Retention** The amount of precipitation on a drainage area that does not escape as runoff. It is the difference between total precipitation and total runoff.

**Roof Pitch** The slope of a roof expressed as a ratio of its vertical rise to its horizontal span.

**Sash** Any framework of a window. May be movable or fixed; may slide in a vertical plane or pivoted.

**Shed Dormer** A dormer window whose eave line is parallel to the eave line of the main roof instead of being gabled.

**Shed Roof** A roof shape having only one sloping plane.

**Side Gable** Describes the massing of a house having the gable end (or roof ridgeline) perpendicular to the street.

**Side Street Setback** Minimum distance between the side street property line and the Side Yard Facade Zone.

**Side Yard Setback** Minimum distance between the side yard property line and the buildable area.

**Simulated Divided Light** Refers to a light in a window sash that is visually subdivided by applied muntins that simulates a true divided sash.

**Skirt Board** A board set horizontally at the bottom of wall cladding.

**Soffit** The exposed undersurface of any overhead component of a building, such as a beam, cornice, lintel, or vault.

**Stile-and-rail** Type of door construction that utilizes a framework of vertical and horizontal members infilled with panels.

**Swale** An open drainage channel or depression, frequently covered with vegetation, designed to detain and promote the filtration of stormwater runoff.

**Tongue-and-groove** Method of joining materials, usually wood, where a tongue or projection in one board fits the groove of its neighbor.

**Transom** A horizontal bar of wood or stone across a window. Also the window or opening above the transom bar.

**Verge** The edge projecting over the gable of a roof. Also, the area of planting, lawn or pavement between the sidewalk and the curb on a street.

**Vergeboard** An ornamental board hanging from the rake, or verge, of a gable roof; also barge board.

**Vernacular Architecture** A mode of building based on indigenous forms and materials.

**Vocabulary (also Architectural Vocabulary)** A collection of related architectural elements, materials or stylistic conventions used to describe a building or structure.

**Watershed** The topographic boundary within which water drains into a particular river, stream, wetland, or body of water.

**Wing** a subsidiary part of a building extending out from the main portion or body.

# References

- Classical Architecture.* Adam, Robert. Penguin, 1991
- A Pattern Language.* Alexander, Christopher. Oxford, 1976
- American House Styles.* Baker, John. Norton, 2002
- Identifying American Architecture.* Blumenson, John. Rowman & Littlefield, 1995
- The Visual Dictionary of American Domestic Architecture.* Carley, Rachel. Henry Holt, 1997
- The Grammar of Architecture.* Cole, Emily. Bullfinch, 2002
- Clues to American Architecture.* Klein, Marilyn W. and David P. Fogle. Starrhill Press, 1986
- Architecture of the Old South.* Lane, Mills. Abbeville Press, 1993
- A Field Guide to American Houses.* McAlester, V. & L. Random House, 1984
- What Style Is It?* Poppeliers, John. John Wiley & Sons, 1977
- Traditional Details for Rehabilitation and Reconstruction.* Ramsey, C. & Sleeper, H. John Wiley & Sons, 1998
- A Concise History of American Architecture.* Roth, Leland. Westview Press, 1980
- American Homes, An Illustrated Encyclopedia of Domestic Architecture.* Walker, Lester. Black Dog & Leventhal, 1996
- The American Vignola.* Ware, William R. Dover, 1994
- American Architecture Since 1780.* Whiffen, Marcus. MIT Press, 1988

# A Pattern Book History

All across this country, in small towns, large cities, villages and hamlets, you will find remarkably beautiful traditional neighborhoods. Denton is no exception. These collections of houses were designed and grouped together to create a series of neighborhood streets and spaces of remarkable charm and character. Much though we admire the variety and individuality of these houses, we are most struck by the way in which each individual house and public building relates to its neighbors and the consistently high design standards followed by all. There is never a discordant or incorrect house.

Initially, houses and towns were built on the frontier of the wilderness, often far removed from civilization. The rapid growth of our country resulted in a series of building booms, in which thousands of houses were built each decade in each community. And yet, the results of this mass production were carefully crafted houses in a variety of architectural styles, all with superb proportions and ornament. Windows, doors, roof forms, and porches followed complex and sophisticated design principles and patterns.

How was such a sophisticated level of design maintained across so wide a geographic area and for nearly 150 years? There were certainly not enough architects to design each of the houses. Architects did, however, contribute designs and principles to the building industry in a series of builders' handbooks known as Pattern Books. These books contained the principles and key details for a variety of architectural styles. They were the direct descendants of books created since Roman times, the means by which architects have passed along their knowledge of design to builders in remote places. From Vitruvius, to Palladio, to Asher Benjamin, to William Ware, architects provided helpful guides for the building industry.

In the second half of the nineteenth century, Pattern Books became part of builders' marketing programs. These attractively designed books were easy to understand. Their pages combined realistic drawings of houses along with floor plans and important details. There were many choices of floor plans and arrangements of architectural elements, but all used the details and proportions of the style.

Pattern Books set the rules, but each builder found ways of interpreting them, elaborating them, or even bending them. The result is the much-admired balance between individual expression and unity found in traditional neighborhoods. The patterns and elements of style

were expressed differently in each region and often elements were 'cross-bred' across different styles. They represented a consensus among architects, builders, realtors, and home buyers on the way to design buildings and communities. Later on in the early and mid portions of the twentieth century, mail order houses were enormously popular. Companies such as Sears, Alladin, Standard Homes Company, and others, created volumes of varied house designs available directly to consumers.

## A PATTERN BOOK REVIVAL

Our goal in reviving the Pattern Book tradition is to help builders, home owners and architects understand the elements and principles of design that help create the distinct character and image of each distinct tradition.

Urban Design Associates (UDA) Pattern Books are designed as a 'kit of parts,' with a great deal of flexibility for the designers and builders who use them.

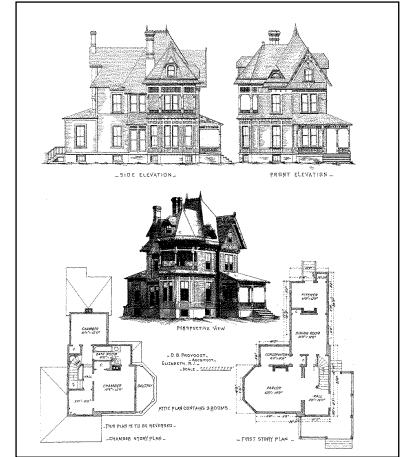

This example of Pattern Book pages originally published by William T. Comstock in 1881 is typical of the books used by American builders through the early part of the twentieth century.

Key construction and proportioning details were illustrated and described in a popular nineteenth-century builder's reference entitled *The Builder's Companion*, by Asher Benjamin (example below).

